

Clarke County Board of Supervisors

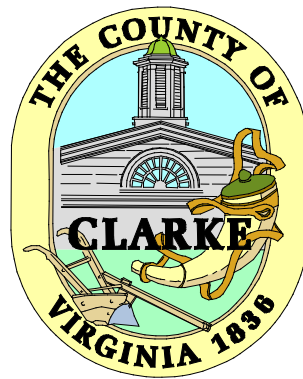

Regular Meeting Packet October 19, 2021



Clarke County Board of Supervisors Regular Meeting Agenda

Main Meeting Room Berryville / Clarke County Government Center
101 Chalmers Court, 2nd Floor, Berryville, Virginia

Item	October 19, 2021	Packet Page
Afternoon Session 1:00 PM		
1. Call To Order		6
2. Adoption Of Agenda		7
3. Citizen's Comment Period		8
4. Employee of the Quarter 2021 Third Quarter Award		9
5. VDOT Update		10
6. Economic Development & Tourism Update		11
7. BoS Minutes:		17
– September 21, 2021, Regular Meeting		18
8. Consent Agenda		51
9. Chet Hobert Park Improvements		52
10. Consideration of an application to the Growth and Accessibility Planning Technical Assistance Program of the Virginia Office of Intermodal Planning and Investment to study an above grade crossing of the Appalachian Trail over Route 7.		56
11. Set Public Hearing, PH 2021-14: SUP-21-01/SP-21-01 Crown Castle International LLC (Tower Owner) and Network Building and Constructing, Inc. (Project Consultant), on behalf of AT&T (Service Provider) for November 23, 2021, at 6:30 pm, or as soon thereafter as the matter may be heard.		58
12. Board of Supervisors Personnel Committee Items from October 12, 2021		99
A. Expiration of Term for appointments expiring through December 2021. Action: The Personnel Committee recommends the following:		
– The appointment of Jerry Stollings as the Court Services Unit Supervisor representative on the Community Policy and Management Team, replacing Kista Opoku-Achampo, for a term expiring December 31, 2022.		
– The reappointment of Rives Bacon for a four-year term on the Handley Regional Library Board, the new term expiring November 30, 2025.		
– The appointment of Linda Bodkin to the Northwestern Community Services Board for a three-year term beginning January 1, 2022, and ending December 31, 2024, replacing Celie Harris, who hits the term limit for this board on December 31, 2021.		
– The reappointment of Chris Boies to the Northwestern Regional Jail Authority, the new term ending December 31, 2022.		
13. Board of Supervisors Work Session Items from October 12, 2021		111
A. School System Update. Action: Information Only		
14. Board of Supervisors Finance Committee Items from October 12, 2021		121

Note: The order in which Agenda items are considered may be changed to assure that public hearings are started as close as possible to the scheduled time

Page 1 of 3

10/13/2021 8:10 PM



Clarke County Board of Supervisors Regular Meeting Agenda

Main Meeting Room Berryville / Clarke County Government Center
101 Chalmers Court, 2nd Floor, Berryville, Virginia

Item	October 19, 2021	Packet Page
A. Independent Accountant's Report on Virginia Retirement System. Action: Information Only.		123
B. Clarke County Department of Social Services Transfer. Action: The Finance Committee recommends approval of transferring \$19,000 from the Social Services FY 22 personnel salaries line item to their FY 22 professional services line item.		125
C. FY21 to FY22 School Capital Projects Carryforward. Action: The Finance Committee recommends approval of the Schools Capital Project Carryforward as requested.		126
D. FY21 to FY22 Government Capital Projects Carryforward. Action: The Finance Committee recommends approval of the Government Capital Projects Carryforward as requested.		128
E. Discussion of 2022-27 Five-Year Capital Improvement Plan. Action: Information Only.		131
F. Review FY23 Budget Calendar. Action: The Finance Committee recommends approval of the FY 23 Budget Calendar as presented.		133
G. Bills and Claims. Action: The Finance Committee recommends approval of the September 2021 Invoice History Report.		134
H. Standing Reports. FYI: Year to Date Budget Report, Reconciliation of Appropriation, and Capital Projects Report. Action: Information only.		145
15. Government Projects Update		159
16. Miscellaneous Items		160
17. Summary Of Required Action		161
18. Board Member Committee Status Reports		162
19. Closed Session Pursuant to §2.2-3711- A8 Consultation with legal counsel regarding specific legal matter(s).		163
Evening Session 6:30 pm		
20. Citizen's Comment Period		164
21. 2021-20R: Resolution of Recognition and Appreciation of Donald "Don" Jackson		165
22. Virginia Department of Wildlife Resources Update, District Wildlife Biologist Fred Frenzel		167
23. PH 2021-11: Code Change, CC 2021-04: Repeal of Chapter 78 Dance Halls		168
24. PH 2021-12: Code Change, CC 2021-05: Repeal of Chapter 189 Outdoor Lighting in Agricultural, Forestal, and Rural Residential Areas		171

Note: The order in which Agenda items are considered may be changed to assure that public hearings are started as close as possible to the scheduled time

Page 2 of 3

10/13/2021 8:10 PM



Clarke County Board of Supervisors Regular Meeting Agenda

Main Meeting Room Berryville / Clarke County Government Center
101 Chalmers Court, 2nd Floor, Berryville, Virginia

Item	October 19, 2021	Packet Page
25. PH 2021-13: Code Change, CC 2021-06: Assignment of New Addresses to Existing Addressed Structures Chapter 56 County Road Naming, Property Numbering and Road Sign System		174
26. Adjournment		178
Reports in Packet:		179
– Building Department		180
– Commissioner of the Revenue		197
– Fire & EMS		206
– Virginia Regional Transit Clarke Metrics Report		207
– Barns of Rose Hill 2020 Annual Report		208

Note: The order in which Agenda items are considered may be changed to assure that public hearings are started as close as possible to the scheduled time

Page 3 of 3

10/13/2021 8:10 PM

Clarke County Board of Supervisors

Call to Order

Clarke County Board of Supervisors

Adoption of Agenda

Clarke County Board of Supervisors

Citizen's Comment Period

Clarke County Board of Supervisors

Employee of the Quarter 2021 Third Quarter Award

Clarke County Board of Supervisors

VDOT Update

Clarke County Board of Supervisors

Economic Development & Tourism Update

Goals

- #1 Convene group of hospitality owners/operators
 - I keep in touch with them as needed to understand what their reality is
- #2 Engage stakeholders on the feasibility of a hotel in Berryville (this would include owners/operators in the region)
 - Work in progress – COVID major consideration right now
 - Talked with a company recently about this – but they come into a locality and look for local financiers and then build
 - In talking with other localities, a majority of the hotels are still having difficulty hiring front line staff – for many, it's almost a self-serve mentality when you check in
 - Locally, the occupancy rate is dropping right now because of cancellations
 - Some local hotels are competing against the Airbnb's and short-term rentals
- #3 Continue efforts on small business attraction, retention and expansion (seminars, promotion, assistance). I have also expanded this to include workforce initiatives and expansion.
 - We have brought in Virginia Career Works, the Virginia Employment Commission and other local and state agencies as needed for networking
 - Working regionally regarding the Worlds of Work!, Workforce Initiative and programs Clarke County schools are currently involved in
 - We continue to work with the schools in making introductions for local businesses and the students
 - See attachment from Christine Kriz – Lord Fairfax Small Business Development Center
- #4 Engage in a dialogue with property owners of vacant buildings and the developable land to spur economic activity.
 - Ongoing.
 - I continue to review weekly
 - Merke property has sold – LVG will be building a warehouse to double the size of their existing space on Station Road
 - Spoke with several property owners recently regarding the Brownfield grant.
 - In talks with some to utilize their front window space for marketing/promotion of Main Street in partnership with Berryville Main Street and the Barns
- #5 Evaluate what is needed to make the Berryville Main Street (BMS) program viable and successful – report back to Joint Committee on recommendation.
 - They have a new president – Michelle Mellon with Edward Jones. Very positive meetings
 - Have developed regular joint meetings with Berryville Main Street, The Barns and Clarke County. Many new programs are in the works including quarterly Meet/Greet meetings for new citizens; regular meetings with local businesses; BMS will be expanding their marketing to include businesses in the County; Business Spotlight enhancement program;

welcome bags for new citizens; and we're working directly with the Ruritans to develop relationships with those organizations/ groups renting the fairgrounds; rack and coupon cards; and Dinner and a Show program at the Barns; a cohesive holiday program with several events tied together; enhanced social media blitz with all three parties; Clarke County will also be working directly with these two outlets to better address quick turn-around needs from VTC and other news outlets wanting information directly on local businesses.

- #6 Formalize website and social media strategies for economic development.
 - Work in progress regarding updates -
 - New website is in design works – will better enable us to post immediately and provide more pertinent information for those who use it

- #7 Establish relationships, and provide training for, realtors in the area.
 - In regular conversations with Blue Ridge Association of Realtors (BRAR) ED Nancy Silva
 - Made introductions with ED and Clarke County High School officials as partnership for teaching students
 - Made BRAR aware of new Waterloo water/sewer program and the potential at Double Tollgate
 - Continue meeting one-on-one with realtors to learn of speedbumps/issues/concerns
 - Continue to offer my assistance for those dealing with properties in Clarke County

- #8 Develop and implement an incentive program using the CARES funding
 - Program completed
 - New funds are available through the American Rescue Plan. We are currently trying to understand how these new funds can be used, and when.

Other projects:

Economic Development

Continue having broadband meetings/updates/phone calls. We are looking at opportunities to use the new American Rescue Plan funds – update on the VATI grant with a partnership with All Points Broadband

Have been pushing the Return to Earn grant program that reimburses companies (up to \$500) for sign-on bonuses. This is a program through the Governor's office.

Will be producing a "Welcome" piece for Ruritans to hand out to officials who are renting/leasing fairground space. Handout will provide my contact information and give ideas on ways that we can assist them in getting the word out about their upcoming programs and we can make introductions with local companies they would need services/products from.

We are still working with the Virginia Health Department; we are coordinating with local businesses to schedule on-site vaccines.

- This is a no-cost program that allows the Health Department to schedule on-site (at the businesses) vaccines for all their employees. This will help to eliminate manufacturing down time while at the same time vaccinating more people.

I continue to have regular update meetings with representatives from our local Department of Social Services to make them aware of several local programs and organizations for partnership opportunities.

I continue to make introductions for companies like Casey Trees who has an immediate hiring need. Introductions include Clarke County High School, Top of Virginia Chamber, Christine Kriz, United Way, and numerous local and state agencies.

Have monthly phone calls with representatives of the Virginia Economic Developers Association (VEDA). We continue to update them on current reality of Clarke County and regionally.

Continue to utilize Christine Kriz from the Lord Fairfax Small Business Development Center.

Regionally (Winchester, Frederick County, Clarke County) we had a meeting with Draper Aden regarding the EPA Community-Wide Brownfields Coalition Grant.

- This is a new opportunity grant program Clarke County agreed to participate in. The program will allow us to work with any property owner who is in need of an environmental site assessment in order to sell their property. This is especially pertinent for any older farms who may have used any chemicals or pesticides. This is a no cost program to the property owner or Clarke County. The program has a total value of \$600,000 with no match required.

Regionally participating in the Startup Shenandoah Valley program. This program works with businesses to identify and address their risks while scaling up.

Continue to meet regularly with Christy Dunkle for updates/catch up.

I continue to meet regularly with Clarke County's Planning and Zoning Directors for updates/catch ups.

I continue to regularly post upcoming events (training, meetings, etc.) on the Economic Facebook page. I also post about opportunities such as free visits from the Health Department

Work/talk continues on both the Waterloo and the Double Tollgate areas. Clarke County is still awaiting final vote from Frederick County regarding our water/sewer request.

Continue hosting weekly meetings with Frederick County and City of Winchester EDAs. Also part of the group is Christine Kriz with Lord Fairfax Small Business Development Center and Cynthia Snyder with the Top of Virginia Chamber.

Regionally we are part of the Small Business Resiliency Team program as part of the GOVirginia – this is in partnership with Lord Fairfax Small Business Development Center. This program assists small businesses with marketing, financial guidance, creation of an e-commerce website and accounting software.

Tourism

Continue to write blogs for state, regional and local use – making it seasonal right now

Continue conversations with our local farmers/farm markets about needs and opportunities

I continue to post regular updates on the Tourism Facebook page highlighting upcoming events, places to visit and things to do.

Expanded blog opportunities listings with the Shenandoah Valley Tourism Partnership (SVTP) and the Shenandoah Valley Travel Association (SVTA)

Evaluating additional signage at the fairgrounds to showcase more of what Clarke County/Berryville have to offer

Continue to update the Virginia Tourism Corporation (VTC) website regarding Clarke County and our assets/businesses.

Have talked with Berryville Main Street and the Barns about utilizing some of our blogs.

We have also been in discussion with them about a potential mural campaign around town.

Discussion is also happening about a potential LOVEWorks program.

Location	Jobs			Jobs			Monthly Total		
	# of Clients	Hours	Start-ups	Created	Retained	Capital Raised	% of total funding	% of clients	% of time
VA: Clarke	9	32					8%	6%	9%
VA: Fauquier	18	51		6	4	\$ 90,000.00	0%	11%	15%
VA: Frederick	62	124	2	2	2	\$ 25,500.00	43%	39%	36%
VA: Shenandoah	21	39		3	5	\$ 107,000.00	14%	13%	11%
VA: Warren	8	8		1			0%	5%	2%
VA: Winchester	41	90	3	27	17	\$ 488,400.00	35%	26%	26%
	159	344	5	39	28	\$ 710,900.00	100%	100%	100%

<u>YTD:</u>									
				Jobs	Jobs		<u>YTD Total</u>		
<u>Location</u>	<u># of Clients</u>	<u>Hours</u>	<u>Start-ups</u>	<u>Created</u>	<u>Retained</u>	<u>Capital Raised</u>	<u>% of total funding</u>	<u>% of clients</u>	<u>% of time</u>
VA: Clarke	20	62		9	32	\$ 1,101,500.00	8%	5.15%	7.30%
VA: Fauquier	36	77		19	62	\$ 563,000.00	0%	9.28%	9.12%
VA: Frederick	143	332	4	17	23	\$ 1,456,108.00	43%	36.86%	39.07%
VA: Shenandoah	49	100		10	14	\$ 397,988.00	14%	12.63%	11.74%
VA: Warren	24	23		3	4	\$ 29,305.00	0%	6.19%	2.74%
VA: Winchester	<u>116</u>	<u>255</u>	<u>3</u>	<u>36</u>	<u>23</u>	<u>\$ 527,525.00</u>	35%	29.90%	30.04%
	388	849	7	94	158	\$ 4,075,426.00	100%	100.00%	100.00%

Clarke County Board of Supervisors

BoS Minutes

– September 21, 2021, Regular Meeting

September 21, 2021

Clarke County Board of Supervisors
Regular Meeting
Main Meeting Room

1:00 pm

At a regular meeting of the Board of Supervisors of Clarke County, Virginia, held in the Berryville Clarke County Government Center, 101 Chalmers Court, 2nd Floor, Berryville, Virginia, conducted on Tuesday, September 21, 2021, at 1:00 pm.

Board Members

Present Afternoon & Evening Session: Matthew E. Bass – Berryville District; Doug Lawrence – Russell District; David S. Weiss – Buckmarsh / Blue Ridge District; Terri T. Catlett - Millwood / Pine Grove District; Bev B. McKay – White Post District

Absent Afternoon & Evening Session: None

County Staff Present

Brenda Bennett, Chris Boies, Joey Braithwaite, Cathy Kuehner, Brandon Stidham, Brianna Taylor, Alison Teetor

Constitutional / State Offices / Other Agencies

Matt Smith, Jim Herron

Press

Mickey Powell – The Winchester Star

Others Present

Mary Ivie and Michelle Worthing

1) Call to Order

Chair Weiss called the afternoon session to order at 1:01 pm.

2) Adoption of Agenda

- At the request of the honorary move Consent Agenda item: 2021-20R Resolution of Recognition and Appreciation of Donald 'Don' Jackson to the October 19, 2021, Regular Board of Supervisors Meeting.

Supervisor Bass moved to adopt the agenda as amended. The motion carried by the following vote:

Matthew E. Bass	-	Aye
Terri T. Catlett	-	Aye
Doug M. Lawrence	-	Aye
Beverly B. McKay	-	Absent
David S. Weiss	-	Aye

3) Citizens Comment Period

Michelle Worthing, Berryville: appeared to address the Board on the HVAC in the Berryville-Clarke County Government Center. She put forth the following:

- I was in the Berryville-Clarke County Government Center yesterday, and employees and citizens in the building were freezing and had to wear sweaters.
- All employees stated that nothing can be done and that they have complained for years and there is just nothing that they can do.
- If the public and staff are uncomfortable, the issue needs to be solved.
- Employees stated that the County owns the building, so that is why I am asking today.
- Why can you not do something? Why can't you get another expert opinion, get a new contractor, or get a new system.
- You should keep your employees and the public happy.

Chair Weiss stated that he usually does not respond to citizen comments, but the HVAC system in this building was inefficiently created from the very beginning. Michelle Worthing suggested getting a new system. Chair Weiss explained that maintenance has fought and continues to fight the battle; the design has been re-engineered at least once. Chair Weiss added that we are aware of it, and we continuously look into it, but once something is in, it is complicated to replace. Michelle Worthing expressed that a new, more efficient system could be put in.

4) Consent Agenda

Application for Easement Donation – Bradley & Kathryn Keister

MEMORANDUM

TO: Board of Supervisors
FROM: Conservation Easement Authority
DATE: August 26, 2021
SUBJECT: Application for easement donation – Bradley & Kathryn Keister – TM# 33-6-H

The Keisters have applied to the easement authority for approval of an easement donation. The property consists of 34.47 acres. The property is located at 240 Ashley Woods Lane, off of Blue Ridge Mountain Road approximately 7/10 mile north of Mt. Weather. The parcel has an existing house built in 2015 and 0 remaining DURs.

The parcel is zoned FOC and is in land use. Therefore the following guidelines for accepting properties for easement donation are used:

- 1) the parcel's Property Resource Score is at least 35;
- 2) at least one dwelling unit right is extinguished by the conservation easement;
- 3) the parcel is adjacent to a parcel already under permanent conservation easement;
- 4) the property has a minimum area of 40 acres.

The Authority requires that a property meet at least two of the four guidelines for acceptance.

The property meets 2 of the 4 criteria by scoring over 35 and being next to an existing easement. The parcel is less than 40 acres. The property resource score is 43.46, points were given for being adjacent to an existing easement and Appalachian Trail property. The Easement Authority gave final approval for the donation at their August 19, 2021 meeting.

Recommendation: Approve the easement donation of Bradley and Kathryn Keister.

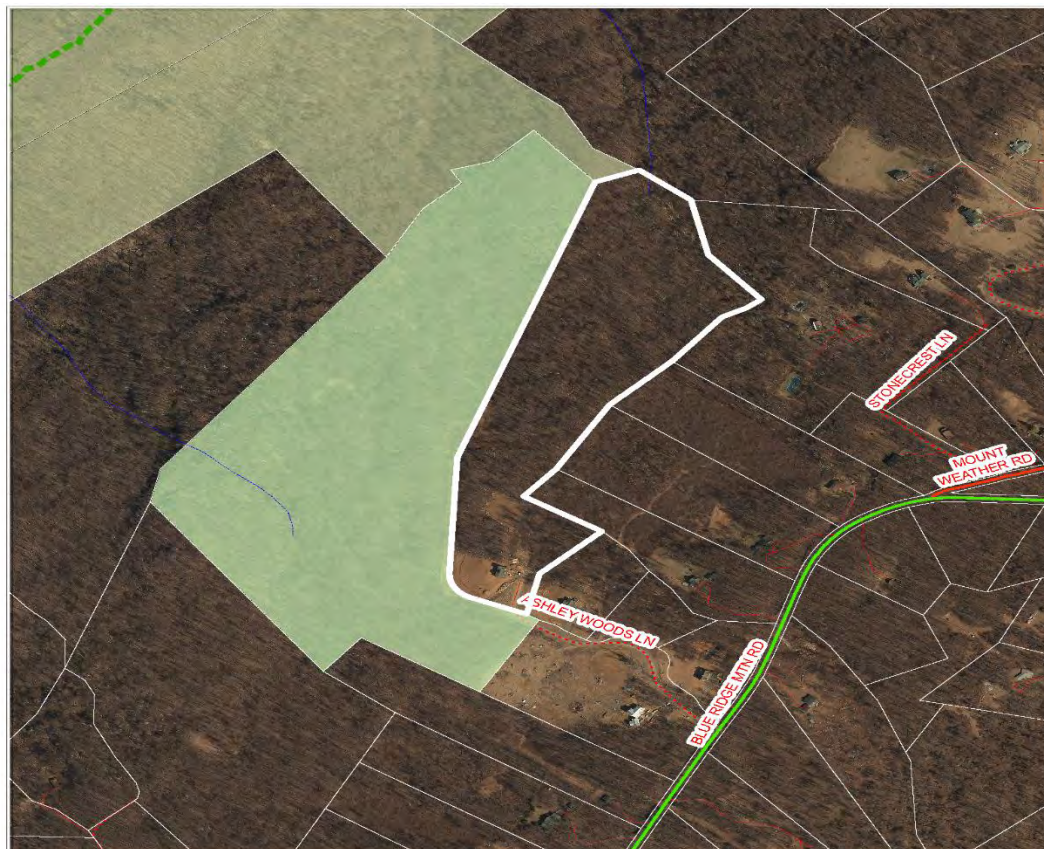

Board of Supervisors Meeting Minutes For September 21, 2021 – Regular Meeting

Application for Easement Donation – Matthew Jones & Diane Sheehey

MEMORANDUM

TO: Board of Supervisors
FROM: Conservation Easement Authority
DATE: August 26, 2021
SUBJECT: Application for easement donation – Matthew Jones and Diane Sheehey – TM# 29-A-35A

Matthew Jones and Diane Sheehey have applied to the easement authority for approval of an easement donation. The property consists of 22.64 acres. The property is located at 1260 Westfield Farm Lane adjacent to Blandy. The parcel has an existing house built in 1905 and 2 remaining DURs. The applicant would like to retire the remaining DURs.

The parcel is zoned AOC and is in land use. Therefore the following guidelines for accepting properties for easement donation are used:

- 1) the parcel's Property Resource Score is at least 35;
- 2) at least one dwelling unit right is extinguished by the conservation easement;
- 3) the parcel is adjacent to a parcel already under permanent conservation easement;
- 4) the property has a minimum area of 40 acres.

The Authority requires that a property meet at least two of the four guidelines for acceptance.

The property meets 2 of the 4 criteria by scoring over 35 and giving up 1 DUR. The parcel is less than 40 acres. The property resource score is 67.62, points were given for retiring 1 DUR, being adjacent to Blandy, being within a portion of the groundwater recharge area, and having several contributing structures in the Greenway Rural Historic District. The Easement Authority gave final approval for the donation at their August 19, 2021 meeting.

Recommendation: Approve the easement donation of Matthew Jones and Diane Sheehey.

Supervisor Catlett moved to adopt the Consent Agenda items as amended. The motion carried by the following vote:

Matthew E. Bass	-	Aye
Terri T. Catlett	-	Aye
Doug M. Lawrence	-	Aye
Beverly B. McKay	-	Aye
David S. Weiss	-	Aye

Supervisor Lawrence suggested that the Resolution of Recognition for Mr. Jackson could be presented in the evening session on October 19, 2021, so that his family could attend. The Board agreed to allow Mr. Jackson to decide if the 1 pm or the 6:30 pm time would work best.

5) VDOT

Matt Smith, Assistant Residency Engineer, provided the following update:

Maintenance

Board of Supervisors Meeting Minutes For September 21, 2021 – Regular Meeting

- Continued with secondary mowing operations and will complete this month.
- Completed prep patching on Rt. 653, Kimble Rd. and Rt. 654, Stringtown Rd.
- VDOT will complete all prep patching for the 2022 paving and surface treatment schedule this month.
- Completed ditching and shoulder repairs on Rt. 653, Kimble Rd., Rt. 632, Crums Church Rd. and Rt. 610, Clifton Rd.
- VDOT began the fall grading schedule for non-hard surfaced roads and will complete this month.
- Cleaned up storm debris on various routes and performed pothole patching.

Board Issues

- Route 7/601 intersections – Scoping has been laid out for evaluating mitigation alternatives.
- Pedestrian overpass on route 7 at Pine Grove Rd. - Is being evaluated as a separate issue from route 7/601.
- Waterloo Park & Ride - Have worked with Clarke County Sheriff's office and Virginia State Police (VSP) to address crowd gathering and reckless behavior. New signs have been posted that will allow enforcement.

Projects

- Held public hearing for route 761, Old Charlestown Rd. bridge replacement. Feedback was generally positive with concerns expressed about the road flooding on the Clarke County side before getting to the bridge.

Supervisor Catlett

- When will the route 7/601 intersection study results be available?
 - o Matt Smith believes that the data will be available in the Spring.
- Who will maintain the intersection? Matt Smith stated that the VDOT Edinburg residency – Clarke County headquarters maintains the intersection. However, he added that it is a joint venture, the Northern Virginia District and Staunton District are working together to try to find solutions for that area.
- There is gravel at the intersection of Browntown Road and route 340 when you are heading south and turn left onto Browntown Road; it is a safety concern for bicyclists.

Supervisor Lawrence

- Thanked VDOT for the open house on the bridge.
- The meeting made it clear that the funding was for the bridge and the apron. All of this time, I thought that why the road was closed down, it would be good to have those parts in the road raised.
- Request to look at ways to fund and do it in the same timeframe as the bridge project. Matt Smith stated that the difficulty would be funding and that project would require additional right of way. Supervisor Lawrence explained that the one (1) landowner is good with giving some of his land and moving his fence back. Another landowner has offered a shale pit for fill.
- Fear on the Clarke County side is that you go across the bridge and then suddenly hit three (3) feet of water in Clarke.

Vice-Chair McKay entered the meeting room at 1:11 pm.

Vice-Chair McKay

- Thanked VDOT for putting the one-way signs on route 50.

Chair Weiss

- On Boom Road, Mr. Carter has been working with Mr. Fraizer at his driveway; my understanding is that signs were put up by VDOT indicating turning vehicles. Mr. Fraizer indicated that the signs have helped, but those signs are no longer there, and not sure where those signs went. Matt Smith stated that he would look into that.

Chris Boies mentioned that staff is still getting calls and complaints about the grass in the medians on route 7. Matt Smith stated that those were just mowed, and Wayne Tapscott told him that staff is aware of the sight issues and they are trying to get those medians situated. Chris Boies asked that VDOT focus on areas around Nalls Market, Wayside Farm, and other places that will be busy with a lot of traffic this fall.

6) Maintenance Department Update

Joey Braithwaite, Director of Maintenance, presented the following:

- Work Orders Completed from January 1, 2021, to September 15, 2021:

Board of Supervisors Meeting Minutes For September 21, 2021 – Regular Meeting

- School: 682
- County: 336
- Total: 1018

- Convenience Center Opened for Fridays from 3 pm to 7 pm, averaging 65 customers. This has helped ease the burden on Sundays.
- Animal Shelter is fully staffed with two (2) full-time and one (1) part-time employee.
- New hires Aislan Borkholder (Animal Shelter) and Brady Burner (Maintenance Department).
- Emergency Communications Center (ECC) fresh air unit installed September 20, 2021.
- Completed County Projects:
 - Animal Shelter – Paved entrance and parking lot.
 - Social Services – Replaced aging Roof Top Unit (RTU).
 - Social Services – New entrance awning.
 - Pool Bath House – Replace toilets, sinks, urinals, and partitions.
 - Circuit Court, General District Court, and Land Survey Office – Cleaned and painted roofs.
 - Government Center – Replaced boiler expansion tank.
 - Commonwealth Attorney Office – renovation for office space.
 - General District Court – new courtroom units (no longer in the attic space).
 - General District Court – New HVAC for judges chamber/conference room.
 - Emergency Communications Center – secondary cooling unit.
 - Park – ballfield fence repair in-house.
 - Park – New storage building.
- On the schedule:
 - Circuit Court Room new chiller and AHU.
- School Projects:
 - Two (2) new classroom HVAC units.
 - Boyce interior and exterior painting.
 - Johnson Williams Middle School (JWMS) – building automation system.

Supervisor Catlett thanked the Maintenance Department for all of their hard work.

Chris Boies explained that with the Capital Projects, staff is thankful to the Board for giving direction early in the fiscal year because of procurement and permitting; getting that early direction allowed the Maintenance Department to complete every project on the carryforward capital projects list. It was great being able to complete those projects because, in the past, that has not always been able to be done.

Chair Weiss complimented Joey Braithwaite’s leadership and explained that the crew is always cheerful.

Joey Braithwaite stated that the HVAC in the Berryville-Clarke County Government Center has always been a challenge, but it is good to be aware of the issues to look into it and see what can be done. Chair Weiss explained that the HVAC was poorly designed from the beginning; a portion of the HVAC system was redesigned to help with humidity issues; asked Joey Braithwaite to keep working on it and see what could be done.

7) Approval of Minutes

August 17, 2021, Regular Meeting

Supervisor Lawrence: Book 25, Page 75: Item 13) Board Member Committee Status Reports under Supervisor Bass: Legislative Updates – High Growth Coalition: change “state thought \$500M” to “state thought \$50M”.

Supervisor Lawrence: Book 25, Page 62: second bullet: change “right away” to “right of way”.

August 31, 2021, Special Meeting

Chair Weiss: Book 25, Page 92: Change “Chair Weiss stated that even though we may be the smallest county, we still may be the last county that is done.” To “Chair Weiss stated that even though we may be the smallest county, we may not be the last county that is done.”

Supervisor Catlett moved to approve the August 17, 2021, Regular Meeting minutes as amended and August 31, 2021, Special Meeting minutes as amended. The motion carried by the following vote:

Matthew E. Bass	-	Aye
Terri T. Catlett	-	Aye
Doug M. Lawrence	-	Aye
Beverly B. McKay	-	Aye
David S. Weiss	-	Aye

8) Set Public Hearing, PH 2021-11: Code Change, CC 2021-04: Repeal of Chapter 78 Dance Halls for October 19, 2021, at 6:30 pm, or as soon thereafter as the matter may be heard

Brandon Stidham, Director of Planning, highlighted the following:

- This code change is to repeal Chapter 78 Dance Halls; this was identified in the Zoning and Subdivision Update Project.
- Early in the Zoning and Subdivision Update Project, we went through the County Code to see if any code sections needed to be referenced in the revised ordinances and looked for potential conflicts.
- Chapter 78 may have been in the County Code for many years and was potentially out of date, and we have discussed this with the County Attorney.
- Dance Halls are not a listed use in either the previous or the revised Zoning Ordinance.
- The code section was adopted under a specific code section in the Code of Virginia that allows localities to regulate public dance halls through a permit process unrelated to zoning.
- However, in Clarke County, we regulate uses through our Zoning Ordinance, so to reconcile this conflict, staff recommends that the Board of Supervisors repeal Chapter 78 Dance Halls.
- It does not appear that the County currently has or ever had a formal permit process outside of zoning to permit dance halls as a separate use. Also, do not have any current dance halls operating in the County.
- This does not ban dancing from Clarke County; it will be regulated under the various uses in the Zoning Ordinance.
- Explained that someone who has a special use permit to operate a minor commercial, public assembly facility with entertainment will be allowed to have dancing.

Historically speaking, Supervisor Catlett asked what a dance hall and where they would have been in Clarke County was. Brandon Stidham read the definition of dance hall from chapter 78 - “Any place, open to the general public, where dancing is permitted, to which an admission fee is charged or for which compensation is in any manner received, either directly or indirectly, by cover charge or otherwise, or where refreshments or food or any form of merchandise are served for compensation before, during or after dancing; and the sale of any refreshments, food or any form of merchandise at such place or the exhibiting of such for sale shall be deemed direct compensation for any such dance hall as is contemplated by this chapter. A public dance hall shall also mean any place where any club, association, corporation, organization or group of persons conduct, operate or permit dances that are open to the public.” Chair Weiss and Supervisor Bass stated that there used to be a couple of places in the County that had dances.

Vice-Chair McKay moved to set a public hearing, PH 2021-11: Code Change, CC 2021-04: Repeal of Chapter 78 Dance Halls for October 19, 2021, at 6:30 pm, or as soon thereafter as the matter may be heard. The motion carried by the following vote:

Matthew E. Bass	-	Aye
Terri T. Catlett	-	Aye
Doug M. Lawrence	-	Aye
Beverly B. McKay	-	Aye
David S. Weiss	-	Aye

- 9) Set Public Hearing, PH 2021-12: Code Change, CC 2021-05: Repeal of Chapter 189 Outdoor Lighting in Agricultural, Forestal, and Rural Residential Areas for October 19, 2021, at 6:30 pm, or as soon thereafter as the matter may be heard

Brandon Stidham, Director of Planning, highlighted the following:

- This code change is to repeal Chapter 189 Outdoor Lighting in Agricultural, Forestal, and Rural Residential Areas.
- The chapter was added to the County Code in January 2007 as a new section; the Planning Commission reviewed and recommended it.
- There were similar outdoor lighting regulations that were adopted around the same timeframe for commercial business activities.
- Staff has not been able to determine why the outdoor lighting regulations for the commercial operations went into the Zoning Ordinance, but the regulations that govern agricultural, forestal, and rural residential areas went into the County Code.
- Sometimes regulations are added to the County Code instead of the Zoning Ordinances to enforce it differently. For example, through police powers, you might want to assign the Sheriff’s Office to be responsible for enforcing some particular rule. Therefore, it is put in the County Code instead of the Zoning and Subdivision Ordinance.
- In conjunction with the Zoning and Subdivision Ordinance project, these regulations were folded into the new Zoning Ordinance. As a result, the requirements for outdoor lighting for AOC and FOC are now found in section 7.4.3. In addition, the requirements for the rural residential district have been added to section 7.5.1 of the Zoning Ordinance.
- This now falls under the Planning Departments Zoning Administrator to apply these regulations.
- Ask for repeal since it is now not necessary to retain in the County Code.

Vice-Chair McKay moved to set a public hearing, PH 2021-12: Code Change, CC 2021-05: Repeal of Chapter 189 Outdoor Lighting in Agricultural Forestal, and Rural Residential Areas for October 19, 2021, at 6:30 pm, or as soon thereafter as the matter may be heard. The motion carried by the following vote:

Matthew E. Bass	-	Aye
Terri T. Catlett	-	Aye
Doug M. Lawrence	-	Aye
Beverly B. McKay	-	Aye
David S. Weiss	-	Aye

10) Set Public Hearing, PH 2021-13: Code Change, CC 2021-06: Assignment of New Addresses to Existing Addressed Structures Chapter 56 County Road Naming, Property Numbering and Road Sign System for October 19, 2021, at 6:30 pm, or as soon thereafter as the matter may be heard

Brandon Stidham, Director of Planning, highlighted the following:

- Add language to the County Code to clarify the situations in which the County will assign a new address to a structure that already has an existing address.
- The primary purpose of the 911 addressing system is to ensure that law enforcement, fire, rescue, and emergency services can find properties when those services are needed.
- Our street address system is based on locating the access point that a structure has to a public street. The numbering system gives you an idea of where on the road the address is; an address of 1000 Lord Fairfax Highway is approximately one mile from the beginning point on Lord Fairfax Highway.
- It is essential that when the addresses are assigned, that staff identifies those on the map based on where the access point is located.
- There can be situations where over time, driveways are moved and need to be readdressed so emergency services can find those locations.
- The most common situation that staff runs into is where a structure is addressed off a primary road but uses a private access easement to get to that road. The private access easement may only have one or two addressable structures. As a rule of thumb, once you get a third addressable structure on a private access easement, that private access easement is assigned a new county road name, and the structures that were previously addressed to where that easement came to the public road are then assigned where their address connects on the access easement.

- Gordon Russell, Director of Information Technology, is responsible for assigning the addresses and the road names as they are established. Sometimes they will arise with subdivisions that create lots of these private access easements.
- On occasion, have situations where staff in the emergency communications center identify problems in specific situations when emergency responders were not able to find a location because of the way it is addressed. Gordon Russell does get recommendations from time to time to reassign an address so that responders can find that property in the future.
- The County does have the authority to assign and change addresses per the Code of Virginia.
- States in County Code chapter 56 that the County can assign a new address if the property owner moves the driveway after the address has been assigned.
- Would like to add two (2) new sections:
 - “If, in the case of an unnamed private access easement, additional structures are addressed which necessitate the assignment of an official street name to the private access easement and issuance of new addresses to all addressed structures that use the private access easement as the primary means of ingress/egress to a public road or another named private access easement.”
 - “Any other situation in which it is the opinion of the County’s Emergency Communications Center Director and/or the Director of Fire, Emergency Medical Services, and Emergency Operations that issuance of a new address or addresses to an existing structure or structures is necessary to ensure efficient provision of emergency services.”
- The number one priority is to get emergency services to find these addresses, want to make sure there is no confusion as to when the County has the authority to make those corrections for that purpose.

Supervisor Lawrence asked, and Brandon Stidham confirmed that if it is a private access easement that is being named and is in conjunction with a minor subdivision application, the fee for the sign is built into the minor subdivision application. If those signs get knocked down, then the County is in charge of replacing them.

Vice-Chair McKay opined that it is essential that the Board does whatever possible to keep the address system updated as things change so that emergency services can find locations.

Vice-Chair McKay moved to set a public hearing, PH 2021-13: Code Change, CC 2021-06: Assignment of New Address to Existing Addressed Structures Chapter 56 County Road Naming, Property Numbering and Road Sign System for October 19, 2021, at

6:30 pm, or as soon thereafter as the matter may be heard. The motion carried by the following vote:

Matthew E. Bass	-	Aye
Terri T. Catlett	-	Aye
Doug M. Lawrence	-	Aye
Beverly B. McKay	-	Aye
David S. Weiss	-	Aye

11) Board of Supervisors Personnel Committee Items

A. Expiration of Term for appointments expiring through November 2021.

2021-09-13 Summary: The Personnel Committee recommends the following:

- Appoint James Willis to a three-year term on the Community Policy and Management Team. This term has been unfilled since January 1, 2021, and will end on December 31, 2023.
- Appoint Elissa Goshen to a three-year term on the Northwestern Community Services Board. This term has been unfilled since January 1, 2021, and will end on December 31, 2023.
- Appoint Doug Lawrence to fill the unexpired term of Jimmy Wyatt on the Northwestern Regional Jail Authority, the term expiring on December 31, 2023. Mr. Lawrence was previously an alternate on the Jail Authority.
- Appoint Sheriff Roper to fill the unexpired term of Jimmy Wyatt on the Northwestern Regional Juvenile Detention Center Commission, the term expiring on December 20, 2024.
- Reappoint Ben Cochran to the Clarke County Industrial Development Authority for a term expiring October 30, 2025.
- Reappoint William Waite to the Clarke County Industrial Development Authority for a term expiring October 30, 2025.

2021-09-21 Action: Chris Boies reviewed the Personnel Committee recommendations.

Supervisor Lawrence moved to accept the appointments. The motion carried by the following vote:

Matthew E. Bass	-	Aye
Terri T. Catlett	-	Aye
Doug M. Lawrence	-	Aye
Beverly B. McKay	-	Aye

David S. Weiss - Aye

B. Appointment of Litter Committee Members

2021-09-13 Summary: The Personnel Committee recommends the following:

- Appoint Ashley Harrison, Meg Roque, John Keim, and Mary Martin to the Litter Committee for three-year terms expiring on September 30, 2024.

2021-09-21 Action: Chris Boies reviewed the Personnel Committee recommendations. Vice-Chair McKay added the following:

- Appoint Thomas Baughan to the Litter Committee for a three-year term expiring on September 30, 2024.

Supervisor Bass volunteered to be the Chair-appointed Board Liaison for the Litter Committee.

After discussion, the Board agreed to set the term length to three years, have a Chair-appointed Board liaison, and the staff representative to be the Natural Resource Planner position in the Department of Planning.

Chair Weiss appointed Supervisor Bass the 2021 Board liaison for the Litter Committee.

Supervisor Bass moved to accept the appointments for the Clarke County Litter Committee. The motion carried by the following vote:

Matthew E. Bass	-	Aye
Terri T. Catlett	-	Aye
Doug M. Lawrence	-	Aye
Beverly B. McKay	-	Aye
David S. Weiss	-	Aye

Chair Weiss directed staff to contact the newly appointed members and set up the organizational meeting.

Supervisor Lawrence asked, and Chair Weiss confirmed that the State does not allow signs in the public right of way. Chris Boies stated that the County has an agreement with VDOT that enables the County to take those signs down for them.

C. Appointment of Alternates for the Fire & EMS Commission

2021-09-13 Summary: No action at this time.

2021-09-21 Action: Chris Boies explained that staff is waiting on names from the Fire Companies, so this could potentially be an item on the October Personnel Committee.

D. COVID Sick Leave

2021-09-13 Summary: The Committee recommends the proposal outlined in the memo to provide additional COVID leave for qualifying employees.

2021-09-21 Action: Chris Boies reviewed the following memo.

To: Personnel & Finance Committee

From: Chris Boies

Re: Proposed COVID Leave

Date: August 30, 2021

At the request of the Finance Committee, staff has developed a proposal for a new COVID leave program. Previously the federal government required employers to provide up to 80 hours of leave to employees for valid COVID reasons. That requirement expired on December 31, 2020. We had a number of employees on leave after December 31, 2020, for valid COVID reasons. We are proposing the following:

Reimburse full-time employee sick leave balances for COVID leave taken between January 1, 2021, through June 30, 2021, for up to 80 hours per employee (this time does not carry forward if unused after June 30). The County will not receive financial reimbursement for this leave.

Provide up to 80 hours of additional COVID leave for full-time employees for time taken between July 1, 2021, through June 30, 2022, for valid COVID reasons if the following conditions are met:

Employee is vaccinated and provides appropriate documentation.

Telework is determined to not be an option.

The County will use federal American Rescue Funds to reimburse for this additional leave granted. Valid COVID reasons include being sick because of COVID, quarantining as directed by a medical professional or county staff because of COVID, or caring for an immediate family member who has COVID or is quarantining because of a COVID exposure.

Regular part-time employees, as defined in the Personnel Policy, would receive 20 hours of COVID leave for each period listed above, consistent with sick leave accrual rates found in the Personnel Policy.

Chair Weiss stated that the Personnel Committee, as a committee, is not advocating whether someone should be vaccinated or not. Feel that if you are not vaccinated, that is your choice, but the County will not cover your COVID sick leave since you had the opportunity to be protected.

The Supervisors brought up the federal order; Chris Boies explained that currently, no one is under that order because Virginia OSHA has not approved it. He further stated that VACo announced that we would qualify as an employer under that order, but it has not happened yet. In the future, we will have to require vaccinations or weekly testing, and the health care providers do not have enough tests right now, so there is a disconnect between the supply and demand of tests and this new mandate. It will create issues for employers to figure out. Chair Weiss stated that the County always follows the State/Federal laws once they are in effect.

Supervisor Lawrence asked, and Chris Boies confirmed that there could be unique situations, for example, a new employee who has not had time to get fully vaccinated while employed in the County. Chair Weiss explained that the premise of the Personnel Committee recommendation was to be fair to employees; I believe that if you bring the Personnel Committee a case where you are following that idea of being fair, the Board would consider it. Chair Weiss further explained that the Board would like to know of those situations.

Supervisor Lawrence moved to adopt the proposal outlined in the memo to provide additional COVID sick leave for qualifying employees. The motion carried by the following vote:

Matthew E. Bass	-	Aye
Terri T. Catlett	-	Aye
Doug M. Lawrence	-	Aye
Beverly B. McKay	-	Aye
David S. Weiss	-	Aye

12) Board of Supervisors Work Session Items

Board of Supervisors Work Session Agenda
Berryville/Clarke County Government Center, 2nd Floor
101 Chalmers Court, Berryville, Virginia 22611

September 13, 2021, 10:00 AM, Meeting Room AB

Board Members Present: Matthew E. Bass, Terri T. Catlett, Doug M. Lawrence, Beverly B. McKay, David S. Weiss

Board Members Absent: None

Officers / Staff Present: Brenda Bennett, Chris Boies, Cathy Kuehner, Brandon Stidham, Travis Sumption, Dawn Hatzler

Others Present: None

Press Present: Mickey Powell – The Winchester Star

2021-09-13 Summary: At 10:00 am, Chair Weiss called the meeting to order.

- A. Discussion on the Town of Berryville Annexation Request. Planning Director Brandon Stidham provided a brief history of the annexation agreement between the Town and County and the accompanying area development plan. He noted the properties requested to be annexed by the Town were within the area development plan, and any development occurring on these properties was expected to be done in accordance with the approved plan. The Board, by consensus, agreed to consider for a vote at their regular meeting in September the written agreement required to move this request forward.

- B. Discussion on Taxation Options for Utility-Scale Solar Projects. The Board heard from staff on new opportunities allowed in the state code to enter into siting agreements for utility-scale solar projects. These voluntary agreements allow the solar developer to offer financial compensation to the locality for various purposes. In addition to siting agreements, the Board heard of two options for taxing certain utility-scale solar projects including through the machine and tools tax and through a revenue sharing program. Staff will bring back to the Board more details on how the siting agreement process will work and an analysis on the machine and tools tax option versus the revenue sharing model.

The meeting was adjourned at 10:55 am.

2021-09-21 Action: Chris Boies explained that in the discussion on the Town of Berryville Annexation Request, the Board heard that this Annexation Area was part of the larger planning scheme that was done in the County where zoning in the rural parts was limited by the sliding-scale zoning to push residential development to the Towns. This annexation agreement with the Town of Berryville was a part of that strategy to focus growth where there are available public utilities. The annexation agreement has three provisions that allow the Town of Berryville to annex properties within the area. The first is if the County already approves development for the properties, they rezone it for development. The second is if the Town subdivides the property and provides water and sewer to the property, developing the property. The third is if both

the Town and the County agree to the annexation; this is the provision the Town is requesting.

Supervisor Bass asked, and Chris Boies explained that if the County had already approved development for the property, it would not have come to the Board. Or if the Town had subdivided because the Town has the power to subdivide outside of their corporate limits but within the annexation area. If the Town had approved a subdivision, it would have been automatic and not come to the Board.

Supervisor Bass moved to approve that “The Board of Supervisors of the County of Clarke hereby agrees to the Town of Berryville's June 24, 2021 request to annex the following properties in Annexation Area B, pursuant to 3.c of the Agreement Defining Annexation Rights dated December 12, 1988: Tax Map Parcel 14-((A))-6 containing approximately 8.93 acres, Tax Map Parcel 14A2-((20))-A 1 containing approximately .55 acres, Tax Map Parcel 14A2-((20))-A containing approximately 9.24 acres, Tax Map Parcel 14-((A))-81 containing approximately 11.47 acres, Tax Map Parcel 14-((A))-80 containing 97.84 acres, and Tax Map Parcel 14-((A))-112 containing approximately 2.19 acres, and that said annexation, if approved by the Berryville Town Council will become effective on January 1, 2022. The motion carried by the following vote:

- Matthew E. Bass - Aye
- Terri T. Catlett - Aye
- Doug M. Lawrence - Aye
- Beverly B. McKay - Aye
- David S. Weiss - Aye

Supervisor Bass stated that he does not represent everyone within Town limits due to the district limitations. Still, I think that, by in large, my constituency at least feels that the primary burden of annexation on their daily lives. Felt compelled to express the following:

"When you see the long-planned developments of Shenandoah Crossing and Freindship Square going up by Green Hill Cemetery, with obvious views from Route 7, and then hear about Annexation and the possibility of more development coming down the pipeline, it is tempting to jump to the conclusion that you're witnessing the oft-dreaded expansion of Berryville beyond its small-town nature.

But it's important to be aware that, as our Chairman has stated and this Board has echoed, what you're actually seeing is plans that have been in the works for decades finally coming to fruition. Part of the reason why Clarke County, with its

sliding scale zoning, retains its unmistakably rural culture is that we focus our development on what I call "building out" – maximizing the potential of the Town of Berryville within its relative, logical, geographical limits. That's a big part of why the Annexation Agreement was entered into years ago. Planners then foresaw that it would allow us to control future growth in the County so you don't see random housing developments popping up in cornfields like we see all around us in other counties.

I recognize that the perception is near-constant development. I also recognize that the housing market here is as robust as perhaps its ever been. And without a doubt, so do the developers involved in these projects. But as much as I dislike ever-present construction, I'm also optimistic for our Town.

With any luck our small businesses and restaurants will see additional patronage that helps them stay afloat, particularly in these difficult times – and maybe, as a result, some of those empty Main Street storefronts will come back to life sooner rather than later. I'm excited for our school system that will hopefully see increased enrollment bringing our schools closer to their holding capacity; and our Parks & Rec that will hopefully see increased participation and activity. Most of all, however, I'm excited to see the grand plans of great planners-past now take shape in my lifetime.

Yes, there will be some who will be profoundly impacted by new development. That is inevitable whenever and wherever development takes place. Others (like me) will simply miss the viewsheds as they once existed or detest the collateral nuisances of construction. My sincere hope is that the developers are sensitive to those aspects, and will take steps to listen to and promptly address the concerns of neighbors, ensure buffer zones, minimize viewshed impact, and deliver products that fit well with the landscape and character of Clarke County."

Chair Weiss stated that he hopes the Town can empathize with the people living in these new developments; it is the plan coming to fruition. Shall remember that it will affect people's lives, but I think it will bring positives as well, such as school attendance and more people buying items in the Town of Berryville. Always like to welcome new people here who admire the charm of Clarke County.

Chris Boies reviewed the summary from work session Item B - Discussion on Taxation Options for Utility-Scale Solar Projects; he added that staff would bring back more information and possible opportunities at a future work session.

Vice-Chair McKay commented that he went to the VACo meeting and learned that 36,640 megawatts of solar power are installed / in the queue to be installed in Virginia. That would take 576 square miles; as a comparison, Clarke County is 176 square miles, therefore, four times the size of Clarke County to complete

those projects. Supervisor Catlett stated that it would be nice to do the projects on parking garages and other areas so that all of the lands are not taken up. Supervisor Lawrence explained that a state law is being looked at to increase electric bills to help fund some of these projects; we will have to see what happens.

13) Board of Supervisors Finance Committee Items

- A. Health Department Carryforward Request: Per the memo and email, the Lord Fairfax Health District shows an end-of-year credit of \$86,637.04 attributed to the Clarke County Health Department for FY21. This credit is due to vacancy savings, as well as an influx of Federal funds specific to COVID needs. The Lord Fairfax Health District is requesting to retain the credit and carry it forward into FY22. These funds will be used to fill staff vacancies and offset the 5% salary increase by the Commonwealth. The Finance Committee should consider approval of the carryforward.

2021-09-13 Summary: The Finance Committee recommends approval of the carryforward request of \$86,637.04 to the Lord Fairfax Health District.

2021-09-21 Action: Brenda Bennett reviewed the Finance Committee recommendation. The credit is due to vacancy savings and the influx of funds due to COVID needs. Lord Fairfax Health Districts would keep the credit and use it in the FY22 fiscal year. The funds would be used to offset vacancies and cover the 5% increase in salaries by Virginia. Representatives from the Lord Fairfax Health District were at the Finance Committee meeting to give an overview and answer questions. Brenda Bennett further explained that historically this request had been brought to the Board of Supervisors for approval, so that is why it was presented at the Finance Committee.

Supervisor Lawrence asked, and Chris Boies confirmed that the 5% was not included in their budget request for FY22.

Chair Weiss stated that historically the Board does not like to use carryover for expenses, but this is more a case that they did not spend them because they did not have people, but they anticipate having them and keeping those in the FY23 budget request. Supervisor Catlett explained that there was a hiring freeze and a loss of staff.

Supervisor Catlett moved to approve the carryforward request of \$86,637.04 to the Lord Fairfax Health District. The motion carried by the following vote:

Matthew E. Bass - Aye
Terri T. Catlett - Aye
Doug M. Lawrence - Aye
Beverly B. McKay - Aye
David S. Weiss - Aye

- B. Sheriff's Office Bonuses: The memo from the Commonwealth of Virginia Compensation Board provides a summary of the language/funding for an FY22, one-time bonus payment of \$3,000 for each Compensation Board funded sworn positions in the Clarke County Sheriff's Office. The total number of Compensation Board funded positions for the Clarke County Sheriff's Office is 13, which equals a total bonus and related benefit amount of \$41,984 to be paid and subsequently reimbursed by the Compensation Board. The Sheriff's Office currently has 16 sworn officers (3 not in Compensation Board funded positions). If the Finance Committee considers providing the \$3,000 bonus to all 16 Sheriff's Office sworn positions, the total expenditure would be \$51,672, leaving a difference of \$9,688 to be paid by the County. The Finance Committee should consider approval of the bonus payments.

2021-09-13 Summary: The Finance Committee recommends the following language, "Be it resolved that FY22 Sheriff's Office budgeted expenditure and appropriation be increased by \$41,984, and revenue from the Commonwealth be recognized by \$41,984, for the purpose of providing bonuses to eligible Sheriff Office employees."

2021-09-21 Action: Brenda Bennett reviewed the Finance Committee recommendation; she explained that after talking to the Sheriff's Office, the additional funding for the other three additional sworn officers could be covered by the Sheriff's Office approved budget.

Chair Weiss stated that the issue in the Constitutional Offices is always the question of fairness; two (2) deputies could be riding in the same vehicle, but one (1) is paid entirely by the compensation board, and the county pays one (1). He added that he appreciates the Sheriff's Office covering this cost within their budget.

Supervisor Lawrence asked, and Chris Boies explained that there had been deputies that have retired in the last six months; he further said that the Board could do what they wish, added that deputies did receive another bonus last year through the state in addition to the county bonus in lieu of a pay increase. Then there was hazard pay, so all of the deputies working at that time received all of those benefits. He added that some localities that did a bonus did not give

the Sheriff Deputies a bonus, but Clarke County did because they felt that that was important.

Brenda Bennett stated that the implementation deadline is November 30; with the Boards' approval, the staff intends to pay these bonus payments with the October payroll. The criteria from the Compensation Board is that the person needs to be in the sworn position for just under the last six (6) weeks to qualify.

Vice-Chair McKay moved, "Be it resolved that FY22 Sheriff's Office budgeted expenditure and appropriation be increased by \$41,984, and revenue from the Commonwealth be recognized by \$41,984, for the purpose of providing bonuses to eligible Sheriff Office employees." The motion carried by the following vote:

Matthew E. Bass	-	Aye
Terri T. Catlett	-	Aye
Doug M. Lawrence	-	Aye
Beverly B. McKay	-	Aye
David S. Weiss	-	Aye

C. Discussion of American Rescue Plan Fund Uses: (see attached)

2021-09-13 Summary: The Finance Committee recommends approval of allocating American Rescue Funds for the following purposes; \$3,200 to convert four water fountains to water bottle filling stations, \$11,200 for extra cleaning and supplies for after-school and summer programs, \$5,500 for extra cleaning and supplies for the Recreation Center, \$250 for hand sanitation stations for Voter Registration, and \$50,000 in lost revenue to be used for cybersecurity.

2021-09-21 Action: Brenda Bennett reviewed the Finance Committee recommendation. Chris Boies explained that the Board is receiving \$2.8M of American Rescue Plan Funds. A majority plus more will be used for the broadband VATI project. Staff did ask for some smaller items, and the Finance Committee did recommend those items for the Board to review. Chris Boies then listed the items included in the packet and added that the Finance Committee did not recommend the reimbursement for COVID leave; therefore, it was not on the list of recommendations.

Chair Weiss stated that with the reimbursement, the Finance Committee felt that it was a liability that the auditors would levy against us on the audit for the COVID sick leave. Finance Committee felt that the \$10K could be spent

differently and that in the end, there may be a lower amount of leave than estimated.

Chair Weiss questioned, and Chris Boies confirmed that he had reached out to Blue Ridge Legal Services – they have not heard back from any localities of what they will do for funding. Talked to the City of Winchester and Frederick County about the Laurel Center – they are both working on a process for non-profits to apply for aid, but that has not been finalized. Therefore, there are no definite amounts for either entity from other localities. Chair Weiss indicated that the Finance Committee thought those were important services for our community, and both have been affected. The Finance Committee recommends that the Board would consider a request for both the Blue Ridge Legal Services and the Laurel Center once there is more information.

Supervisor Catlett moved to allocate American Rescue Plan Funds for the following purposes; \$3,200 to convert four water fountains to water bottle filling stations, \$11,200 for extra cleaning and supplies for after-school and summer programs, \$5,500 for extra cleaning and supplies for the Recreation Center, \$250 for hand sanitation stations for Voter Registration, and \$50,000 in lost revenue to be used for cybersecurity. The motion carried by the following vote:

Matthew E. Bass	-	Aye
Terri T. Catlett	-	Aye
Doug M. Lawrence	-	Aye
Beverly B. McKay	-	Aye
David S. Weiss	-	Aye

D. Bills and Claims

2021-09-13 Summary: Following review, the Finance Committee recommends the approval of the August 2021 Invoice History Report.

2021-09-21 Action:

Supervisor Catlett moved to approve the August 2021 Invoice History Report. The motion carried by the following vote:

Matthew E. Bass	-	Aye
Terri T. Catlett	-	Aye
Doug M. Lawrence	-	Aye
Beverly B. McKay	-	Aye

David S. Weiss - Aye

E. Standing Reports

- Year to Date Budget Report
- Reconciliation of Appropriations
- Capital Projects Report

2021-09-21 Action: Information Only

14) Joint Administrative Services Board Update

Brenda Bennett highlighted the following:

- Met on August 24, 2021.
- The status of unemployment claims has slowed down significantly, discussed that the Virginia Employment Commission has increased their subsidy amount to pay these claims from 50% to 75%. At this point, the County is responsible for 25% of the claims that come in quarterly.
- Health Insurance coverage through Benefit Plan Administrators (BPA) has monthly newsletters from the healthiest you program. These newsletters are being sent out to all employees, both government and school.
- General discussion on the timeline would need to look like for our health insurance renewal; have a lot of data to look at, and examine various scenarios with the plans.
- Chris Boies and I have a meeting planned for next week to voice their concerns with the BPA insurance. Chris Boies encouraged all employees to come and voice their concerns. The information for the meeting will be in the Clarke Communicator.

15) Government Projects Update

Chris Boies provided the monthly project update:

- United Day of Caring
 - o A team of about a dozen county employees participated in the United Way Day of Caring this past Wednesday; we worked on a project at Heritage Day Care here in Berryville.
 - o A team from United Bank performed work at the county park and completed spreading mulch at the big playground, painted four dugouts, painted the concession stand and bathroom at the pool, and weeded the flower bed and mulched at the pool and tennis courts.

- Another group from Truist Financial helped trim shrubs, cleaned the front porch and steps at the Historical Society building.

Chair Weiss complimented Chris Boies for initiating the program for Clarke County. Chris Boies conveyed that staff is already planning on more ways to get the community to request projects next year. Chris Boies gave the example of the Ruritan Fairgrounds and stated that if the organization provides the materials, then United Way provides the labor. Chris Boies expressed that he has the hope to grow the program throughout Clarke County. Supervisor Catlett stated that the Animal Shelter could have a few projects.

- All Points Broadband/NSVRC VATI Application
 - Submitted last week as part of an eight-county application, including Augusta, Clarke, Fauquier, Frederick, Page, Rappahannock, Rockingham, and Warren Counties. The total for the regional project is \$97M.
 - The state released the following information on the applications received as part of the program:
 - 57 applications representing 84 localities
 - \$943,300,424 in requested funding.
 - \$1,159,125,288 in matching funds.
 - Approximately 300,000 proposed locations, homes could be served by these projects.
 - October 21 – VATI Challenges Due
 - November 18 – Deadline for Challenge Rebuttals
 - December 3 – Department of Housing and Community Development (DHCD) notifies All Parties of Challenge Determination
 - Late December – Anticipate Announcement of Award

Supervisor Lawrence asked, and Chris Boies stated that the challenges would go to VATI. First, VATI will notify the Northern Shenandoah Valley Regional Commission (NSVRC), then NSVRC will quickly pass them onto All Points Broadband and the localities. Then we will all work closely together to get the information needed for the rebuttals.

Vice-Chair McKay asked, and Chris Boies explained that anything slower than 25 Mbps up and 3 Mbps down is unserved. The challenge criteria are very specific.

Supervisor Catlett questioned, and Chris Boies indicated that there are two different challenge processes. The first could start the latter part of this week, and another period around the mid-October range.

Supervisor Bass asked what kind of evidence is used to rebut these challenges. Chris Boies stated that the County would potentially if they said a resident was served, but they are not, then staff may go to your house and ask you to sign a document similar to an affidavit. Chris Boies added that another thing that could be done is to go to the incumbent website and type in the address, and if it says it cannot serve you, we will take pictures to prove. Finally, Chris Boies explained that the option of online surveying had been discussed.

- Citizen’s Academy
 - Started last week.
 - We have 16 individuals participating in the inaugural program.
 - I want to thank Brianna Taylor and Cathy Kuehner for presenting to the group.
 - As well as David and Terri Catlett for participating in our local government officials forum
 - We have a great group of individuals in the program and got off to a good start last week.
- Broadband Special Meeting
 - Wanted to thank Brianna Taylor for organizing the special meeting the Board held on broadband; a special meeting requires an extra set of notifications, an extra packet, minutes, etc., and she helped make everything happen.
 - It was a very important meeting, and I appreciate her help behind the scenes.
- Announced that Tiffany Kemp had her baby boy.
- Legislative Luncheon – Brianna Taylor
 - Have reserved four dates at Parks and Recreation – will send out those dates to confirm what works best.
 - Would like to cater the food in from a local business.
 - Will reach out to the Senators and Delegates to see when would work best.
- VACo Voting Credential for the Business Meeting – Brianna Taylor
 - Supervisor Catlett and Vice-Chair McKay will be attending the VACo Conference in November.
 - Chair Weiss stated that the Board has always had the VACo member have voting privileges in the past. Supervisor Catlett noted that would be fine.

By consensus, the Board agreed to have Supervisor Catlett be the voting member for the 2021 VACo Business Meeting in November.

16) Miscellaneous Items

Fee For Service – Fire & EMS Commission

Supervisor Lawrence requested that there be a new project for the Fire & EMS Commission. This Board voted on the Fee For Service to give the mileage to the Fire Companies, and the process for doing that is not very clear if the Fire & EMS Commission could help with that and then get the information back to this Board and the Fire Companies.

Norfolk Southern

Supervisor Bass stated there was an issue two weeks ago, where the train was stopped on the tracks in the Town of Berryville in the evening when people were trying to get home. Supervisor Bass conveyed that he realizes that this has been an issue in the past, with trains potentially stopping on the tracks or moving very slowly and delaying traffic. Drafted a letter to Norfolk Southern outlining specific safety concerns for the Board to look at before sending. He then explained that the Town of Berryville has taken steps in the past to try to address it with Norfolk Southern, and nothing has happened. Thought that it was worth trying to send a letter to Norfolk Southern inviting them to dialogue with us to see if there was anything they could do to prevent a bad situation from happening.

Vice-Chair McKay stated that four (4) to five (5) years ago, the Northern Shenandoah Valley Regional Commission had a meeting for Rockland Road to limit how long a train could block the road. Supervisor Bass conveyed that without giving formal legal advice, the problem with that is that that statute is invalid under Federal Law.

Supervisor Lawrence inputted that the simple solution would be for Norfolk Southern to put signs up to indicate to the Train Engineers that if you have this many cars, you are blocking the road. He added that the letter should be sent and suggested copying the Department of Transportation in Richmond.

Chair Weiss stated that it was brought to Congresswoman Jennifer Wexton's attention the last time it happened.

17) Summary of Required Action

<u>Item</u>	<u>Description</u>	<u>Responsibility</u>
1.	Reach out to Don Jackson to see if he could attend the October Evening Session	Brian Lichty
2.	Process the Application for Easement Donation – Bradley & Kathryn Keister	Alison Teetor
3.	Process the Application for Easement Donation – Matthew Jones & Diane Sheehey	Alison Teetor

- | | | |
|-----|---|-------------------|
| 4. | Process approved minutes for August 17, 2021, Regular Meeting Minutes, and August 31, 2021, Special Meeting Minutes | Brianna R. Taylor |
| 5. | Advertise the Public Hearing Notices | Brandon Stidham |
| 6. | Execute notice of appointments | David S. Weiss |
| 7. | Process appointments and update the database | Brianna R. Taylor |
| 8. | Process COVID Sick Leave under the new policy | Brenda Bennett |
| 9. | Execute the Annexation Agreement | David S. Weiss |
| 10. | Process the Annexation Agreement | Brianna R. Taylor |
| 11. | Process Health Department Carryforward Request | Brenda Bennett |
| 12. | Process Sheriff's Office Bonuses | Brenda Bennett |
| 13. | Process the American Rescue Plan Fund Uses | Brenda Bennett |
| 14. | Process Bills and Claims | Brenda Bennett |
| 15. | Email meeting date options for the Legislative Priorities Meeting to Board and Legislators | Brianna R. Taylor |

18) Board Member Committee Status Reports

Supervisor Matthew E. Bass

- Board of Septic and Well Appeals
 - No meetings.
- Library Advisory Council
 - Met yesterday.
 - Christopher Curran resigning, represented the Buckmarsh District, will reach out to Laurine Kennedy.
 - Will be on the Personnel Committee in October.
 - 41% up in circulation from last July.
 - Seeing increasing activity.
 - Unfortunately, with the Delta Variant, they have not been able to do in-person programming.
 - Have online book club and trivia.
- Planning Commission
 - At the last meeting, set Public Hearing for increasing the height of an existing 110-foot wireless communications facility by ten (10) feet; that public hearing was set for the October 1 Business Meeting. That tower is at Quarry Road.
 - Continue the discussion on short-term residential rentals text amendment.

- Josephine School Community Museum Board
 - Nothing to report.
- Legislative Updates – High Growth Coalition
 - Rappahannock Electric Cooperative legal challenge. Is occurring.
 - Chris Boies explained that All Points Broadband is aware of the lawsuit and is following it closely.
- Sheriff Office
 - Met on August 20th.
 - A group of new hires has just completed the academy; they will be introduced in the near future.
 - One deputy is switching to part-time.
 - Sergeant Jason Hough is retiring.
 - Commend the Sheriff's Office for the time and extra shifts they have done in the tough past year and a half.
- Town of Berryville
 - Increase in water and sewer fees Mickey Powell did an article in the Winchester Star. Supervisor Catlett stated that the water and sewer were discussed at the citizen's academy; it was interesting to hear all the background information.
 - Annexation discussion was voted on today.

Vice-Chair McKay

- VACo Summit
 - Discussed solar energy.
 - Attended the Agriculture Committee Meeting; VACo wanted to address Nonpoint Source Runoff from agricultural operations. I finally convinced them to finish the statement with runoff because it does not matter where it is coming from.
 - There is \$75M in Federal Recovery Funding to DEQ for septic straight pipe collection system repairs, replacements, and upgrades. Chris Boies stated that he would look into that and see if some could be used for septic pumping.
- Berryville-Clarke County Joint Building Committee
 - Voted to send a letter to the Library Advisory Council to inform them that we would like them to move the drop boxes to the new drop box area. Supervisor Bass stated that it was discussed at their last meeting, and there are varying opinions.
 - The Board agreed that chairs at the dais need to be fixed or replaced.
- Northern Shenandoah Valley Regional Commission
 - Meets on Thursday at Belle Grove Plantation. Supervisor Lawrence stated that he would like to attend.
- Town of Boyce
 - Whiting Avenue is one-way.
 - VDOT is going to paint some crossways across route 340.

- Clarke County Sanitary Authority
 - The State did water samplings at two locations; one was a church, and the other was a business that is currently closed. Both samples were high in lead and copper, but the State has finally agreed that it is not a Sanitary Authority issue because all of their piping is plastic; it is the location's plumbing. The State is allowing the Sanitary Authority to test two different locations
 - Working on maintenance, changing the generator to a three-phase system.
 - Found a few significant leaks coming from the plant.
 - Meter installation is going well, and it is speeding up the reading of the meters tremendously.

Supervisor Terri T. Catlett

- Career and Technical Education
 - Did not meet.
- Clarke County Historic Preservation Commission
 - Met September 15, added a public comment period.
 - Some residents spoke on signage to acknowledge the Bears Den Historic District. Further, into the meeting, signage for all historic districts was discussed.
 - Going to give an annual report to the Planning Commission and discuss their demolition criteria for the structures in a historic district.
 - Battle of Berryville Project; they have done a lot of preliminary work, done a lot of the surveying, and will hold a public meeting in the near future. Chair Weiss stated that the County is not sponsoring that project; it is the State and Federal Government.
- Clarke County Humane Foundation
 - Had three (3) horses rescued and brought to the County. The Humane Foundation received kind donations from area farmers to feed the horses while at the facility.
 - Will hold an open house in the near future.
- Conservation Easement Authority
 - Missed the meeting.
- Parks & Recreation Advisory Board
 - Did not meet.
- School Board
 - Presentation on their accountability and their accreditation report. The scores are down because of the learning situations during the pandemic. Math was hit harder than English was.
 - Homecoming will be outside at the Wilbur Feltner stadium.
 - Zara Ryan, Russell District, is resigning, the School Board will be appointing in the near future.
- Village of Millwood
 - On the first of October, they will be doing roadside cleanup.

- On October 18, at 6 pm, they are going to have their community meeting. Jean Lee and the archivist at the Historical Association have researched interesting people who have grown up in Millwood. In addition, Jean Lee sent out an email to the community on how to get your Covid-19 vaccination in a digital option.
- CPMT
 - Met yesterday, had a good meeting.
 - Chris Boies gave an update on Closed Sessions.
 - Scott Renner, State Level CSA, gave a presentation on Clarke County data on how money is spent, etc. Very interesting presentation. Chris Boies stated that he complimented the Board greatly for the fund balance set aside because CSA numbers can vary greatly depending on the year. Chris Boies added that Clarke County is spending about \$11K per child and the state average was \$28K.

Supervisor Doug M. Lawrence

- Board of Social Services
 - Jennifer Parker, Director of Social Services, has rewritten the handbook; the Board of Social Services has approved the first three chapters.
 - Hired a firm to do a strategic plan, which will guide the local department.
 - Have a regional group on fostering our expenses have been significant. Our Director is writing them a letter to ask them to see what can change.
- Broadband Implementation Committee
 - Did not meet.
- Berryville Clarke County Joint Committee on Economic Development & Tourism
 - Meets on Friday.
- Northwestern Regional Jail Authority
 - Did not meet.

Chairman David S. Weiss

- Berryville-Clarke County Joint Committee on Economic Development and Tourism
 - Meets Friday.
- Industrial Development Authority
 - Did not meet.
- Fire & EMS Commission
 - Did not meet.

Supervisor Bass gave a public shout-out to Shepherds Ford Production for putting on a fantastic Watermelon's Pickers Fest at the fairgrounds this past weekend. It was well attended, the music was great, and the weather was good; it was very family-friendly.

19) Closed Session Pursuant to §2.2-3711-A1 Discussion on the performance of employees of the public body.

At 3:28 pm, Supervisor Bass moved to enter closed session pursuant to §2.2-3711-A1 Discussion on the performance of employees of the public body. The motion carried by the following vote:

Matthew E. Bass	-	Aye
Terri T. Catlett	-.	Aye
Doug M. Lawrence	-	Aye
Beverly B. McKay	-	Aye
David S. Weiss	-	Aye

At 4:13 pm, the members of the Board of Supervisors being assembled within the designated meeting place, with open doors and in the presence of members of the public and/or the media desiring to attend, Supervisor Catlett moved to; reconvene in open session. The motion carried as follows:

Matthew E. Bass	-	Aye
Terri T. Catlett	-.	Aye
Doug M. Lawrence	-	Aye
Beverly B. McKay	-	Aye
David S. Weiss	-	Aye

Supervisor Bass further moved to execute the following Certification of Closed Session:

CERTIFICATION OF CLOSED SESSION

WHEREAS, the Board of Supervisors of the County of Clarke, Virginia, has convened a closed meeting on the date pursuant to an affirmative recorded vote and in accordance with the provisions of the Virginia Freedom of Information Act; and

WHEREAS, Section 2.2-3700 of the Code of Virginia requires a certification by the Board of Supervisors of the County of Clarke, Virginia, that such closed meeting was conducted in conformity with Virginia law.

NOW, THEREFORE BE IT RESOLVED, that the Board of Supervisors of the County of Clarke, Virginia, hereby certifies that, to the best of each members knowledge, (i) only public business matters lawfully exempted from open meeting requirements by Virginia law were discussed in the closed meeting to which the certification resolution applies, and (ii) only such public business matters as were identified in

the motion convening the closed meeting were heard, discussed or considered by the Board of Supervisors of the County of Clarke, Virginia. The motion was approved by the following roll-call vote:

Matthew E. Bass	-	Aye
Terri T. Catlett	-	Aye
Doug M. Lawrence	-	Aye
Beverly B. McKay	-	Aye
David S. Weiss	-	Aye

No action was taken following the closed session.

20) Adjournment

At 4:14 pm, Chair Weiss adjourned the meeting.

21) Next Regular Meeting Date

The next regular meeting of the Board of Supervisors is set for Tuesday, October 19, 2021, at 1:00 pm in the Berryville Clarke County Government Center, Main Meeting Room, 101 Chalmers Court, Berryville, Virginia.

ATTEST: September 21, 2021

David S. Weiss, Chair

Chris Boies, County Administrator

Recorded and Transcribed by Brianna R. Taylor, Deputy Clerk to the Board of Supervisors

Clarke County Board of Supervisors

Consent Agenda

Clarke County Board of Supervisors

Chet Hobert Park Improvements

Clarke County Board of Supervisors



Berryville Voting District
Matthew E. Bass
(540) 955-5175

Millwood Voting District
Terri T. Catlett
(540) 837-2328

Russell Voting District
Doug Lawrence
(540) 955-2144

Buckmarsh Voting District
David S. Weiss – Chair
(540) 955-2151

White Post Voting District
Bev B. McKay – Vice Chair
(540) 837-1331

County Administrator
Chris Boies
(540) 955-5175

To: Board of Supervisors

From: Chris Boies

Re: Chet Hobert Park Improvements

Date: October 8, 2021

The Parks and Recreation Advisory Board was approached by a citizen, Christy Dunkle, concerning a proposed donation which included certain improvements to Chet Hobert Park. The concept drawing, which is attached, shows a walkway, seating area, and new tree plantings in the area behind the Rotary shelter (on the inside of the interior loop road at the park).

Ms. Dunkle has proposed to complete this project in phases and has asked to plant the trees early next spring. The Parks and Recreation Advisory Board unanimously recommended approval of the tree plantings at their October 6, 2021 meeting. Parks and Recreation staff has noted these plantings are consistent with the park master plan. The Board of Supervisors is being asked to approve the planting of the trees as shown on the concept plan.

Ms. Dunkle has discussed the project with Casey Trees, who has agreed to furnish the 12 trees identified on the concept plan. As there are currently no trees available for a fall planting, she is proposing a spring planting of a mix of redbud and crape myrtle for spring and summer blooms, respectively. She is proposing a volunteer day to plant the trees in mid-to-late March. Ms. Dunkle said that discussion about a drip system for watering the trees should occur to assure the 1"-1.5"-caliper trees get established. She has a commitment for the installation from a local contractor should this be an option. Maintenance staff will review this aspect of the project.

Staff is seeking approval for the planting of these trees next spring.

Concept Plan

DETAIL - CHET HOBERT PARK

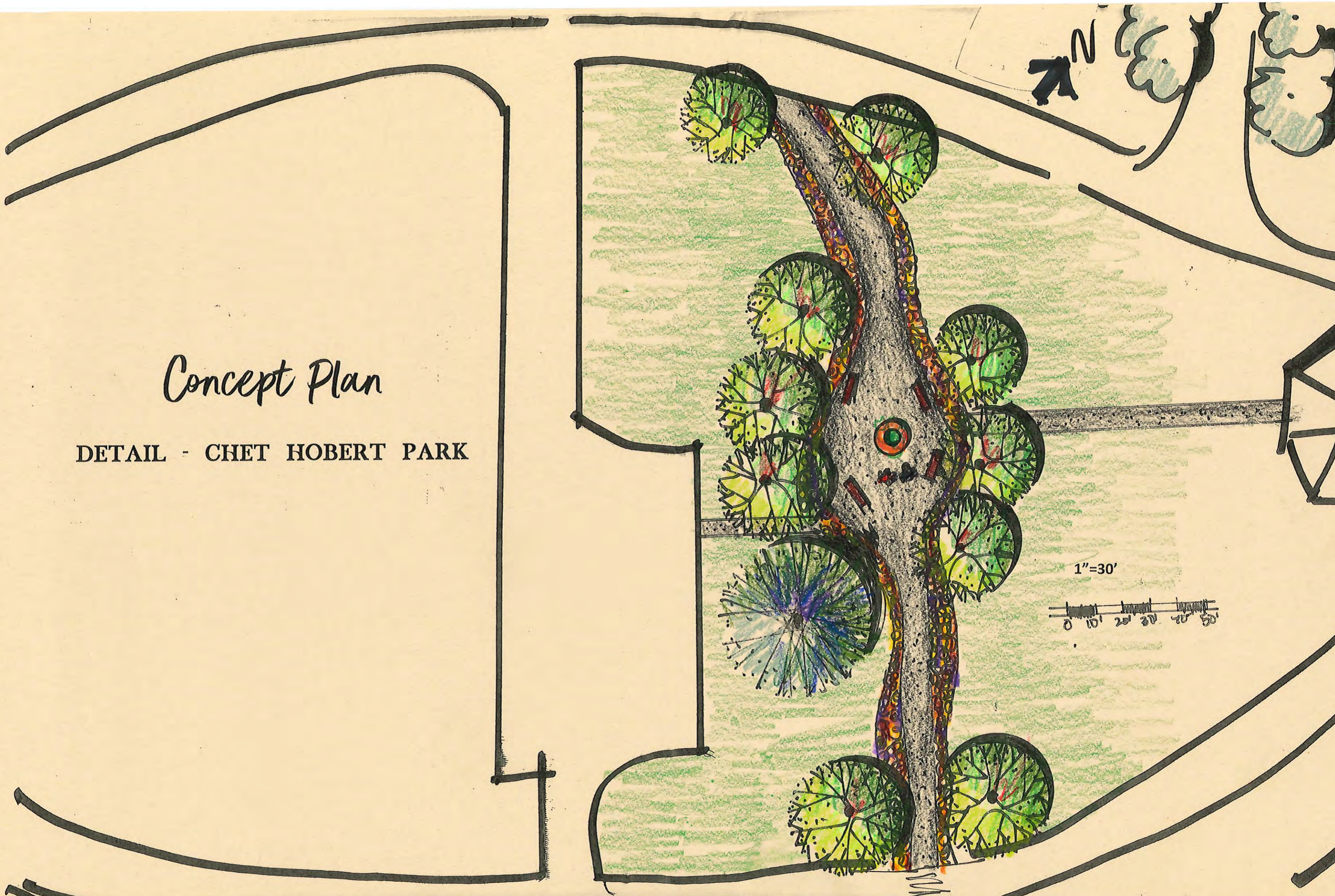

Concept Plan

CHET HOBERT PARK

Parking lot

River rock (variable width)

Eastern Redbud var. (*Cercis canadensis*)

Specimen tree/raised bed planter

Seating area

Existing evergreen

1"=50'



Recreation Center

**Consideration of an
application to the Growth and
Accessibility Planning
Technical Assistance Program
of the Virginia Office of
Intermodal Planning and
Investment to study an above
grade crossing of the
Appalachian Trail over Route 7**

Clarke County Board of Supervisors



Berryville Voting District
Matthew E. Bass
(540) 955-5175

Millwood Voting District
Terri T. Catlett
(540) 837-2328

Russell Voting District
Doug Lawrence
(540) 955-2144

Buckmarsh Voting District
David S. Weiss – Chair
(540) 955-2151

White Post Voting District
Bev B. McKay – Vice Chair
(540) 837-1331

County Administrator
Chris Boies
(540) 955-5175

To: Board of Supervisors

From: Chris Boies

Re: Growth and Accessibility Planning Technical Assistance Program

Date: October 13, 2021

We have been made aware of a technical assistance program through the Virginia Office of Intermodal Planning and Investment, which could be utilized to study the potential above-grade crossing of the Appalachian Trail over Route 7. This program provides funding, with no required match, to conduct multimodal planning outside urbanized areas. The definition of this planning type includes projects which provide pedestrian-friendly road design, connectivity of road and pedestrian networks, and preservation of natural areas. We feel the above-grade crossing project would make a strong application for this funding.

At this point, staff is seeking guidance from the Board on whether to submit an application for this funding. The application deadline is November 1, 2021, with notification to applicants (whether we received the funding or not) on December 3, 2021. If successful, a notice to proceed would be issued in December, and the project could kick off in January of 2022. The project would involve technical assistance from an on-call general planning contractor, which will be selected from a pre-qualified list of firms vetted by the state. A stakeholders group would likely be formed to help guide the process and would include representatives from the National Park Service, VDOT, Appalachian Trail Conservancy, etc. We would likely ask for \$50,000 in assistance to complete this work.

The results of the study would be presented to the Board of Supervisors and could be used as a basis for requesting future federal or state funding for the project (depending on the findings). As mentioned previously, there is no financial commitment required from the County to apply for, and receive, these funds. If approved by the Board, staff will work to complete the application per the deadline noted above.

**Set Public Hearing, PH 2021-14: SUP-21-01/SP-21-01
Crown Castle International LLC (Tower Owner) and Network Building and Constructing, Inc. (Project Consultant), on behalf of AT&T (Service Provider) for November 23, 2021, at 6:30 pm, or as soon thereafter as the matter may be heard.**

SPECIAL USE PERMIT / SITE PLAN (SUP-21-01 /SP-21-01)

AT&T @ Arcadia Farms

**October 19, 2021 Board of Supervisors Business Meeting – For Scheduling Public Hearing
STAFF REPORT– Department of Planning**

The purpose of this staff report is to provide information to the Board of Supervisors to assist them in reviewing this proposed land use request. It may be useful to members of the general public interested in this request.

Case Summary

Applicant:

Crown Castle International LLC (*Tower Owner*) and Network Building and Constructing, Inc. (*Project Consultant*), on behalf of AT&T (*Service Provider*)

Property Owner:

Stuart M. Perry Inc.

Location:

The site of this Special Use Permit (SUP) Application is an existing cell tower at 4163 Harry Byrd Highway. The cell tower is visible from the public highway (Route 7), but setback more than 400 feet from the right-of-way. It is accessible from a driveway off of the eastbound segment of Route 7, located across from the Citco Gas Station. The intersection of Route 7 and Shepherds Mill Road is on the opposite side of Route 7. The property is on Tax Map #16-A-33. It is zoned AOC District, and within the Buckmarsh Voting District.¹



Request:

The Applicant requests an amendment to the existing Special Use Permit (SUP-02-02) and Site Plan (SP-02-09) for the purposes of increasing the tower height by ten (10) feet for an additional carrier (AT&T). SUP-02-02 was approved on March 17, 2003 for a 95-foot monopole tower. The tower was later modified to the currently height of 110 feet. The proposed tower height would reach a height of 120 feet and include space for 4 carriers.

Parcel Size/Project Area: 149 acres / 300 SF lease area by AT&T within an existing 4,900 SF compound.

¹ Planning Commission Representatives: Scott Kreider & Doug Kruhm
Board of Supervisors Representative: David Weiss

Location Map:



AT&T @ Arcadia Farms
 Tax Map# 16-A-33
 Property Owner - Stuart M. Perry



300 150 0 300 Feet

Clarke County GIS
 August 3, 2021

Legend

- parcels polygon
- Structures
- Roads
- Scenic Road
- Intermittent Stream
- Perennial Stream



Illustrations:

PROPOSED EXTENSION

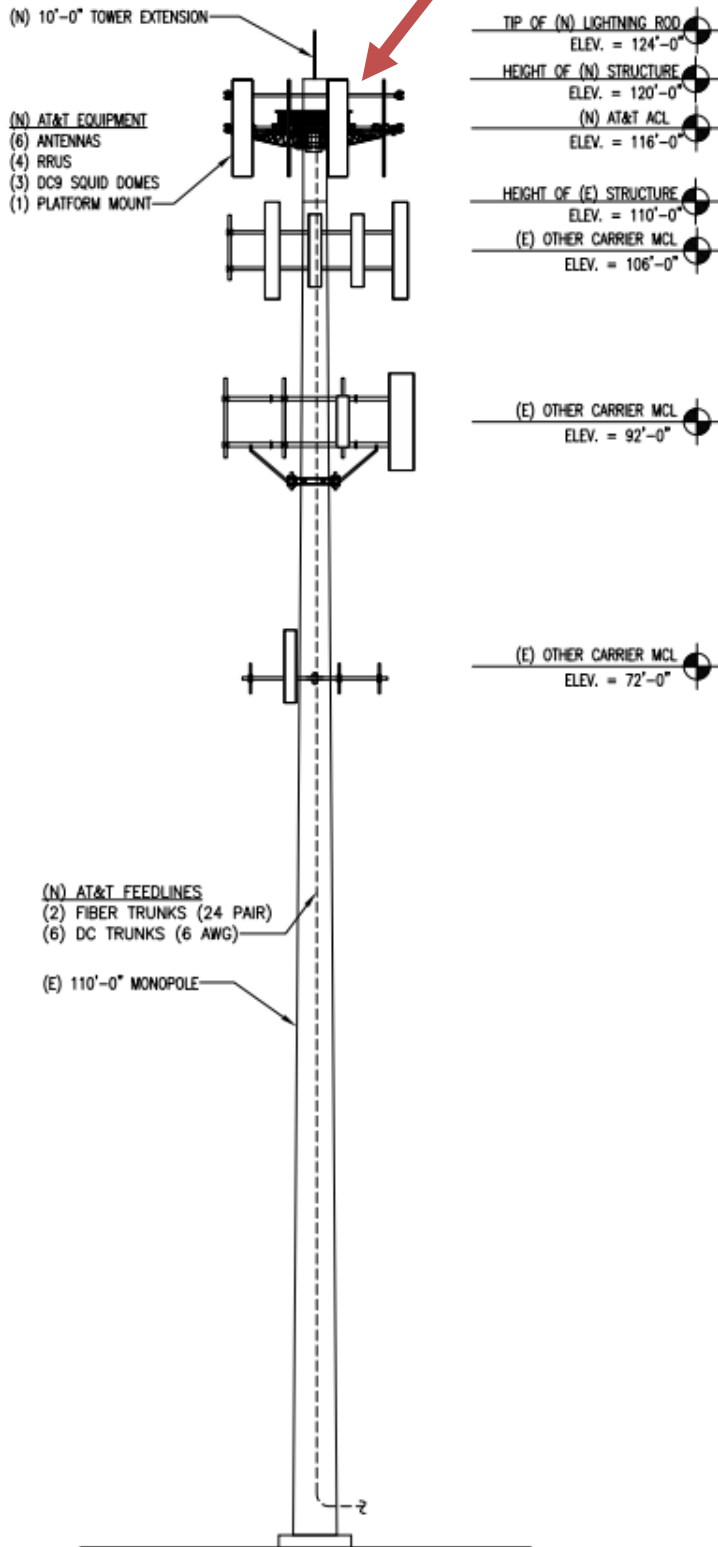

TOWER ELEVATION (1)
 SCALE: N.T.S. C-3

Facts:

The Applicant is requesting approval to construct a 10-foot extension on an existing 110-foot monopole – Class 3 Wireless Communication Facility (WCF). The tower would remain classified as a Class 3 WCF with the proposed change. Pursuant to the Clarke County Zoning Ordinance, 3-C-2-u-2, Class 3 WCFs include facilities that are between 80 and 120 feet in height. Class 3 WCFs are limited to monopole design and require a Special Use Permit.

Staff Note: This application was submitted prior to the adoption of the updated Zoning Ordinance. Therefore, it is being processed under the regulations of the previous zoning ordinance that was in place when the application was submitted. No changes were made to the telecommunication regulations, so the difference is primarily just the code references.

Clarke County Zoning Ordinance, 3-C-2-u-6, includes certain exemptions that are mandated by Federal law. This includes the increase in height of a WCF that does not exceed 10% of the original approved height or by the height needed to provide 20 feet of separation from the closest antenna array location on the WCF, whichever is greater. Due to the previous modification that changed the tower height from 95 feet to 110 feet, the proposed increase does not qualify for this exemption; and therefore, requires an amended SUP.

Omnipoint Communications Cap Operations, LLC originally obtained the “ground lease” for the portion of the subject property containing the easement and compound area on June 28, 2002. The lease grants the ability to construct a tower, install equipment, etc. and runs with the land.

The existing tower is identified in the 2016 Telecommunications Infrastructure and Broadband Study as Existing Tower #9, which is intended to help provide continuous coverage along Route 7 and the surrounding area.

The Applicant has provided a complete application for a Special Use Permit and Site Plan. The submission includes a site plan and other documents. Below is a complete list of documents submitted by the Applicant.

- **Application Form**
- **Letter from Emily O’Grady**
- *Exhibit A - Site Plan with construction details (selected pages provided only)*
- *Exhibit B - Site Plan with survey (selected pages provided only)*
- *Exhibit C - Structural analysis*
- *Exhibit D - Removal Bond Estimate*
- *Exhibit E - Mount Analysis*
- *Exhibit F - Ground Lease*
- *Exhibit G - Map - Topography*
- *Exhibit H - Map - Floodplain*
- *Exhibit I - Map – proximity to nearest School*

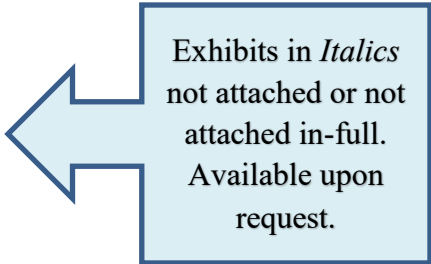

Exhibits in *Italics*
not attached or not
attached in-full.
Available upon
request.

The proposed facility is designed to accommodate an AT&T antenna array at a centerline height of 116’ with up to three other carriers located at lower heights on the tower. The facility will be accessed via the existing entrance shown on the site plan. The proposed parking area will be the gravel access easement which serves only the compound. There are no water supplies or sewage disposal systems existing or proposed. A existing wooded areas surrounding the site provide an adequate buffer to meet code requirements for WCFs. There is no proposed lighting or signage. The existing compound area will not be expanded. AT&T will utilize existing space within the existing compound area.

Site Plan

The Applicant submitted a WCF Site Development Plan containing all of the required elements to constitute a complete application per Article 6 of the Zoning Ordinance. Zoning Ordinance sections 3-C-2-u and 6-H-12 contain WCF specific requirements. The Applicant has addressed these requirements in the site plan and the accompanying narrative. The site plan was routed to the following agencies for their review.

- George Condyles, Atlantic Technology Consultants (County Telecom Engineering Consultant)
- Jamie Royston, Clarke County Department of Building Inspections (Building Official)
- Brian Lichty, Clarke County Fire, EMS & Emergency Management (Director)

Neither Mr. Royston or Mr. Lichty had any comments on the applications. Mr. Condyles, commented that he is of the opinion that the application conforms to all of the County's Design Standards and should be approved. A copy of the report from Mr. Condyles is attached with this Staff Report as supplementary information.

Setbacks

As reported by Mr. Condyles, the collapse zone for this tower has not been supplied by the manufacturer, but is estimated to be 111'.

The required setback for the tower is a distance equal to the WCF Fall Zone. This would be a distance of at least 111'. The existing tower is greater than 400 feet from the front property line. Setback distances from the side and rear property lines range from approximately 800 feet to 2400 feet.

Landscaping

§6-H-12-a-5 of the Zoning Ordinance requires a 50' perimeter buffer around the compound for tree retention and a 25' buffer with supplemental evergreen plantings in a double-staggered row with shrubs necessary to effectively screen the compound and WCF structure base from view. The existing site has a wooded buffer that ranges from approximately 100 feet to approximately 800 feet.



Access and Traffic

The Applicant proposes to use the existing entrance as shown on the plan for the facility entrance.

Erosion & Sediment Control (E&S) / Stormwater

Not required because no land disturbance is proposed.

Water Supply and Waste Water Disposal

Not required.

Karst Plan

Not required because no land disturbance is proposed.

Lighting and Signage

There is no lighting or external signage proposed.

Parking

§4-J of the Zoning Ordinance (Off-Street Parking) does not include a required parking calculation for the proposed use. A proposed gravel access area with pull off area for service vehicles is shown on the site plan.

Removal Bond

The Applicant has estimated the cost of removal of the structure to be \$125,000. Clarke County Zoning Ordinance §6-H-12-c-3 requires a removal bond equal to the cost of removal of the WCF, all WCF and fence footers, underground cables, and support buildings, plus 25%. This bond or letter of credit must be posted at the time of WCF final approval, in the event the County must remove the WCF upon abandonment. The bond shall remain in effect for the life of the WCF. Based on the required 25% contingency, the required bond amount is \$156,250 (\$125k + 25%).

Staff Analysis – Special Use Permit Review Criteria (§5-B-5)

Evaluation of the special use permit request includes an analysis of 19 criteria listed below as set forth in §5-B-5 of the Zoning Ordinance. Staff has provided an analysis of the proposed facility’s compliance with these criteria below.

a. Will be consistent with the Comprehensive Plan of the County.

Staff Comment: A Wireless Communication Facilities (Class 3 & 4) is an allowable special use in the AOC District, therefore the use itself is in general accord with the Comprehensive Plan by virtue of its inclusion in the Zoning Ordinance. The existing tower is identified in the 2016 Telecommunications Infrastructure and Broadband Study as Existing Tower #9.

b. Is consistent with Purpose and Intent of the Zoning Ordinance.

Staff Comment: The Purposes and Intent of the Zoning Ordinance are found in §1-B. Staff has identified no provisions of this section that would result in a conflict with the proposed use.

c. Will not have an undue adverse impact on the short-term and long-term fiscal resources of the County for education, water, sewage, fire, police, rescue, solid waste disposal or

other services, and will be consistent with the capital improvement goals and objectives of the Comprehensive Plan, to the end that growth of the community will be consonant with the efficient and economic use of public funds.

Staff Comment: There will be no impact to the school system. Water and sewer service are not required. The Fire and EMS Director had no comments on the application. Additional police service or rescue service is not anticipated. Solid waste generated by the proposed use will be handled by the Applicant but should be minimal. The proposed use requires no public funds.

- d. Will not cause an undue adverse effect on neighboring property values without furthering the goals of the Comprehensive Plan to the benefit of the County.**

Staff Comment: The use of property values alone as an evaluation criterion can produce very subjective outcomes depending on the perspective of the particular appraiser or advocate. Property values can vary due to a wide variety of elements and can be a very subjective determination that a proposed use is the sole source of a potential negative impact on property values. Staff instead recommends evaluating the overall effect of tangible impacts such as noise, traffic, odor, safety, light pollution, and visual appearance to determine impacts on surrounding properties. In Staff's opinion, the proposed 10-foot increase in height to the existing tower will not generate any significant new impacts.

- e. Will not cause an undue adverse effect on the preservation of agricultural or forestal land.**

Staff Comment: Staff has not identified any issues associated with this request that would affect the preservation of agricultural or forestal land. The subject property does not adjoin any existing conservation easement properties and will not have any adverse impact on nearby properties in agricultural use. The existing tower is located on property that is primarily used as a quarry.

- f. Will not cause unreasonable traffic congestion or unsafe conditions on existing or proposed public roads and has adequate road access.**

Staff Comment: No changes are proposed to the existing entrance.

- g. Will not cause destruction of or encroachment upon historic or archeological sites, particularly properties under historic easement.**

Staff Comment: The property does not contain any historic or archeological sites.

- h. Will not cause an undue adverse effect on rare or irreplaceable natural areas, areas of outstanding natural beauty, state-designated scenic byways or scenic rivers or properties under open space easement.**

Staff Comment: No further impact outside of the existing WCF is proposed. The additional ten (10) feet in height appears to be a minimal impact.

- i. Will not cause an undue adverse effect on wildlife and plant habitats.**

Staff Comment: No further impact outside of the existing WCF is proposed. The additional

ten (10) feet in height appears to be a minimal impact.

- j. Will have sufficient water available for its foreseeable needs.**

Staff Comment: *No water is proposed, nor necessary.*

- k. Will not cause unreasonable depletion of or other undue adverse effect on the water water source(s) serving existing development(s) in adjacent areas.**

Staff Comment: *No water is proposed, nor necessary.*

- l. Will not cause undue surface or subsurface water pollution.**

Staff Comment: *Karst review was not necessary for the proposed use.*

- m. Will not cause an undue adverse effect on existing or proposed septic systems in adjacent areas.**

Staff Comment: *No effect.*

- n. Will not cause unreasonable soil erosion.**

Staff Comment: *E&S plan review is not required as land disturbance is not proposed by the Applicant. The Clarke County Building Department will monitor erosion control during construction.*

- o. Will have adequate facilities to provide safety from flooding, both with respect to proposed structures and to downhill/downstream properties.**

Staff Comment: *No land disturbance is proposed and the property is not located within a floodplain. Review by DEQ is not required for the proposed use.*

- p. Will not cause undue air pollution.**

Staff Comment: *Zero to minimal air pollutants will be emitted from the WCF.*

- q. Will not cause undue noise, light or glare, dust, odor, fumes, or vibration.**

Staff Comment: *Minimal noise, dust, odor, fumes or vibrations are associated with the proposed use. The tower is not proposed to be lighted.*

- r. If in the AOC or FOC zoning districts, will not result in scale or intensity of land uses significantly greater than that allowed under the permitted uses for these districts.**

Staff Comment: *The proposed facility is consistent with the Zoning Ordinance regulations.*

- s. Will not cause a detrimental visual impact.**

Staff Comment: *The setback and wooded buffer around the site will mitigate visual impact similar to current conditions.*

Staff Recommended Special Use Permit Conditions:

Staff has provided the following list of Special Use Permit Conditions to address the various issues with this request discussed in this report and in previous Staff Reports. These are recommended conditions for the Commission to consider and may be amended, added to, or deleted.

1. **Special Use Permit purpose; nontransferable.** This Special Use Permit is issued for the subject property for operation of a Class 3 Wireless Communication Facility (WCF) solely by the Applicant, Crown Castle. The Special Use Permit shall not be transferable to any other person or entity without prior approval of the Board of Supervisors as an amendment to the approved Special Use Permit conditions, such approval not to be unreasonably withheld.

2. **Applicant and Property Owner (“Owner”) to sign list of adopted permit conditions.** The Applicant shall sign the list of adopted conditions to indicate receipt of the conditions and the intention to comply fully with the conditions for the life of the Special Use Permit. A signed copy of the conditions shall be provided to Planning Department Staff (“Staff”) within thirty (30) days of the Applicant’s and Owner’s receipt of the adopted conditions.

3. **Access for inspections required.** Staff and other County officials shall have access to the property with 24 hour notice to the Applicant in order to conduct periodic compliance inspections of the facility and the subject property throughout the life of the permit.

4. **Ongoing maintenance of site features.** The following site features shall be properly maintained throughout the life of the permit:
 - Property entrance shall be maintained consistent with VDOT regulations.
 - Access for emergency service and law enforcement shall be permitted.
 - Security fencing shall be maintained throughout life of the project.

5. **Bonding.** Prior to construction taking place to increase the height as proposed, the Applicant shall post a bond or letter of credit with Clarke County for use in the event that the County must remove the WCF upon abandonment. This bond or letter of credit shall be maintained for the life of the WCF. It shall be in the amount of the cost to remove all features of the WCF, plus 25%.

Recommendations:

During the October 1, 2021 Planning Commission Meeting, a public hearing was held on the subject application. The Planning Commission voted unanimously to issue a conditional approval of the Site Plan Application and a recommendation of approval to the Board of Supervisors in regards to the Special Use Permit Application. Their recommendation of approval included the 5 conditions advised by County Staff and documented above in this report.

During Board of Supervisors meeting on October 19th it is recommended that the required public hearing be scheduled by the Board of Supervisors.

History:

May 28, 2021	Pre-Application meeting held with Planning Staff.
July 19, 2021	Complete Special Use Permit and Site Plan Applications filed by the applicant.
August 6, 2021	The Planning Commission Business Meeting for August was canceled per the adopted schedule of meetings. Filing deadline for the September 3, 2021 Planning Commission Business meeting.
August 31, 2021	PC Work Session.
September 3, 2021	PC Business Meeting – Set Hearing Date
October 1, 2021	PC Business Meeting – Public Hearing

Attachments: Report from Atlantic Technology Consultants, Inc.
Application and letter with select pages of Exhibits A and B.



**CLARKE COUNTY, VA
TECHNICAL REVIEW**

**SPECIAL USE PERMIT AMENDMENT
(SUP-20-01)
Revision of SUP-02-02**

Proposed: 10-ft Height Extension on Existing "Class 3" 110-ft Monopole

By

CROWN CASTLE & NB&C

For

AT&T Mobility

At

**4163 Harry Byrd Highway
Berryville, VA 22611**

Submitted by:

ATLANTIC TECHNOLOGY CONSULTANTS, INC.
A Member of The Atlantic Group of Companies

ATC PROJECT #: 1150-04

July 23, 2021



THE ATLANTIC GROUP
OF COMPANIES INC.

New Wireless Antenna Site Review Standards:

Information is limited by the following Virginia Statute.

The Virginia General Assembly's passage of House Bill 1258, which was signed into law by the Governor on April 18, 2018, invalidates the aforementioned requirement. Please see Va. Code Section 5.2-2316.4:2A.1, which provides that, in its receiving, considering, and processing of an application or for any zoning approval required for a standard process project, a locality shall not disapprove an application on the basis of an applicant's business decision with respect to its designed service, customer demand for service, or quality of its service to or from a particular site, and Va. Code Section 15.2-2316.4:2A.2, which provides that a locality shall not require an applicant to provide proprietary or other business information, such as propagation maps and telecommunications traffic studies, to justify the need for the project in its current location.



EXECUTIVE SUMMARY

Crown Castle International LLC (Crown Castle) the Tower Owner and Network Building and Constructing, Inc. (NB&C) jointly on behalf of AT&T Mobility (AT&T) has made application to the County for the Amendment of an existing Special Use Permit SUP 20-01 to allow addition of a height extension of ten (10) feet for a new overall height of 120' AGL height on a monopole telecommunications tower. The property located at 4163 Harry Byrd Highway, Berryville, VA. Parcel # 16-A-33, owned by Perry Stuart M Inc. whose address is 117 Limestone Lane, Winchester, VA. The original Special Use Permit SUP-0202 was granted on February of 2002.

AT&T is an FCC licensed telecommunications provider authorized to provide digital wireless service to the Clarke County area in conjunction with Crown Castle and NB&C and proposes the addition of ten (10) feet AGL however keeping the amended structure a Class 3 Wireless Communications Facility (WCF) 120' monopole style tower to support service delivery in an area with a lack of AT&T coverage in the corridor known as the Harry Byrd Highway.

This report outlines the specific areas of evaluation with respect to this proposal, and this consultant's recommendations regarding the Application as presented.

It is the opinion of this consultant that the application conforms to all of the County's Design Standards regarding the construction of telecommunications support structures outlined in the current ordinance for Wireless Communications Facilities and should be approved.



George N. Condyles, IV CPM
President and COO
Atlantic Technology Consultants, Inc.

1.0 TECHNICAL

1.1 Siting

The tower site is an existing 70' x 70' compound within a 75' x 75' leased area (0.104 acre) on the edge of unimproved forested land located on a tract owned by Perry Stuart M Inc. AT&T plans to sublease a 12'x 25' smaller area within the existing 70' x 70' fenced compound. See below.

AT&T Sub-Lease (12' x 25') within the 75' x 75' leased area.

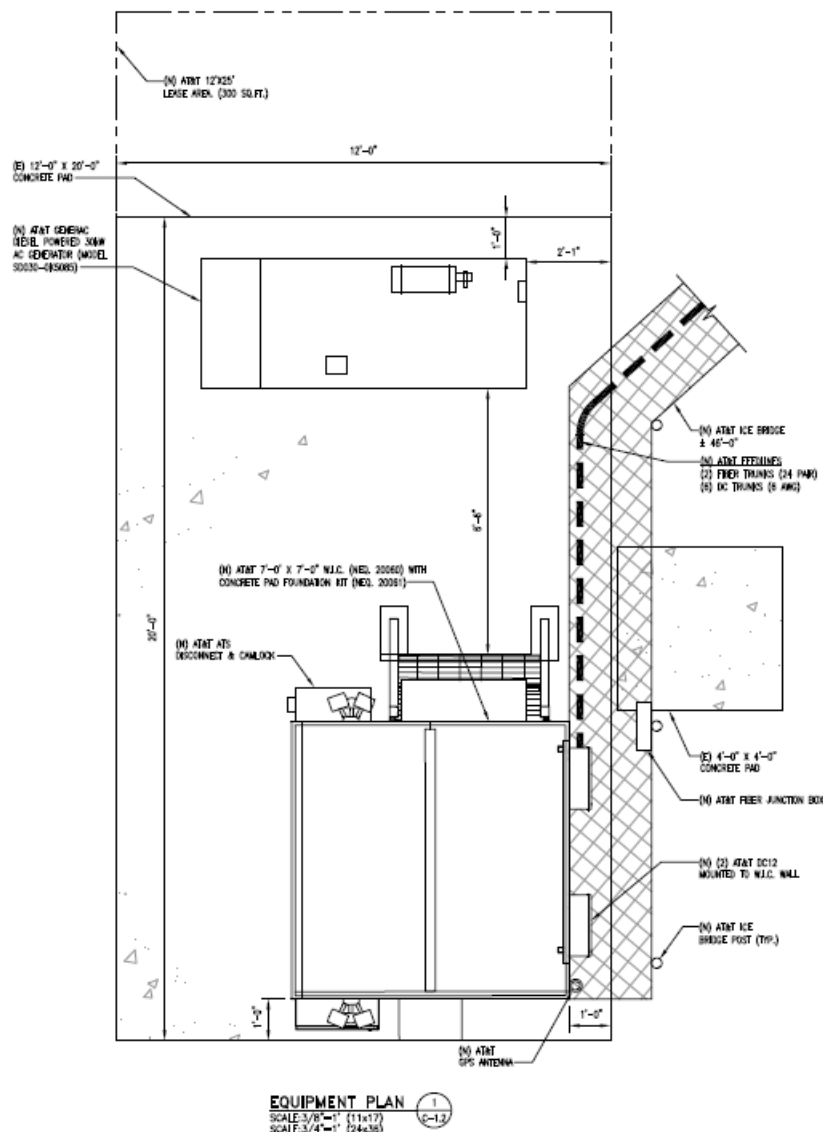

The "Parent" tract of 149 acres is located on County Deed Book 606 Page 863, tax Map 16-A-33. The property is zoned AOC.

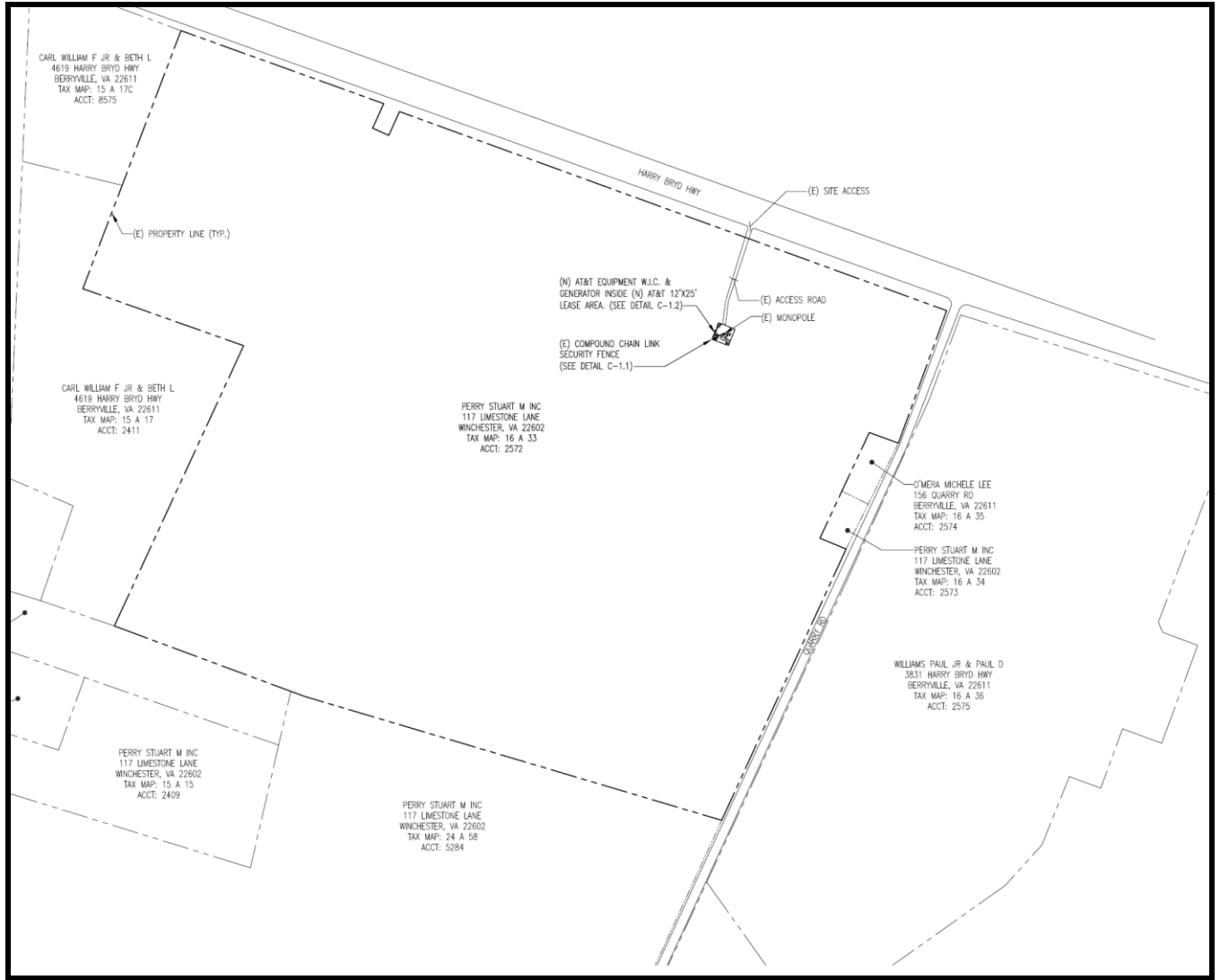

Clarke County Zoning Requirements

ZONING DISTRICTS FOR WIRELESS COMMUNICATION FACILITIES

Class	AOC	FOC	CH	CN	RR	Historic Overlay*	Historic Access Overlay*
Co-Location	A	A	A	A	A	A	A
1 (max 50')	P	P	P	P	P	X	P
2 (max 80')	P	P	P	P	P	X	P
3 (max 120')	S	S	S	X	X	X	S
4 (max 199')	S	S	S	X	X	X	S
5 (am. radio)	P	P	P	P	P	P	P
6 (antenna support structure)	P	P	P	P	P	X	P

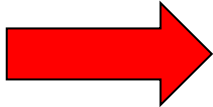

P - Permitted/by-right S - Special Use
 A - Accessory use X - Prohibited use

* - Subject to the underlying zoning district regulations and compliance with overlay district review criteria.

The tower/WCF extension will remain in the **Class 3** WCF 120' AGL Monopole tower category. Site placement as described represents the location of most minimal visual impact to the surrounding area and parcels. As noted by the Applicant this site will blend with existing natural vegetative screening and tree coverage. This tower site selection is in the geographic northeast area of the parcel to have access to Harry Byrd Highway. The tower site will have limited visibility from any adjacent property owners.

Upon reviewing the supplied Site Plan drawings, the size of the compound will remain the same within the 70'x70' fenced area. The over all leased area of 75'x75' or 5,625 square feet exceeds the requirement of design standards for *Wireless Communications Facilities (WCF) 6-H-12-a: 6. Other Design Requirements a Compound Design Requirements* with a not to exceed measurement of "2,500 Square Feet."

This requirement was instituted after the construction of the WCF Ordinance and therefor is "grandfathered."

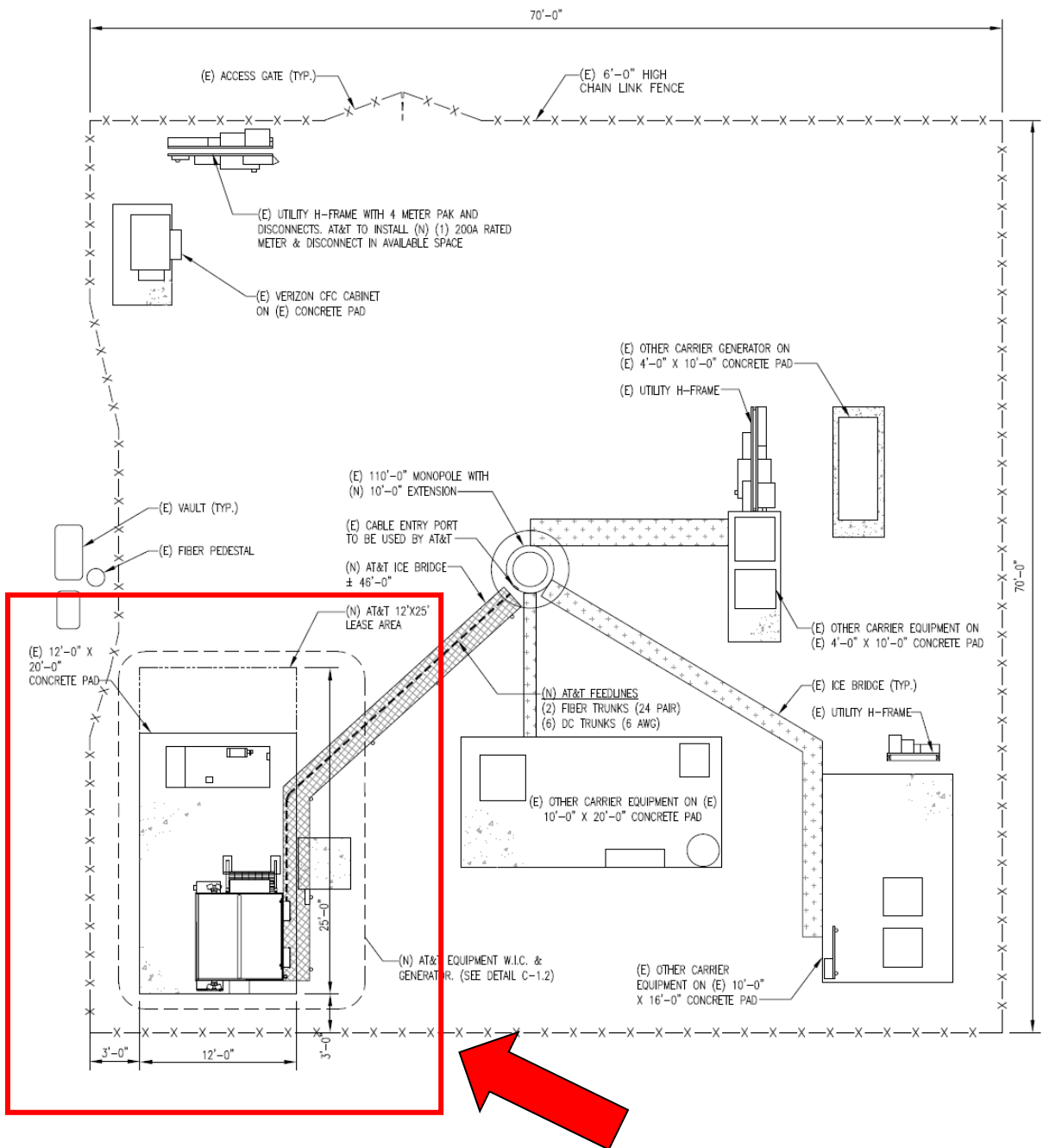

Landowner approval for this site has been documented and supplied.

Set Backs

The “collapse zone” for this tower has not been supplied by the manufacturer. Today’s technology in the design of the structure allows the tower to buckle at approximately 40% of the height then fall unto itself with the 60%.

Typically, this would be less than 120’ in radius. In this case 60% would be approximately 111’ feet.

The closest property line boundary is over 1000’ from the boundary.

There are no homes or inhabited/occupied structures within the Fall Zone.

1.2 Structural

The proposed 120-foot monopole tower design is of high strength steel, and represents a highly stable structural design not known by this consultant to have failed at any installation in this region. This structure, as proposed, is well within compliance of EIA/TIA-222-G guidelines (the accepted industry standard) for structures and the National Building Code which is mandated to withstand the structural loading of all appurtenances, plus additional wind and ice loading. The size of the proposed tower makes this design an ideal choice to support the proposed appurtenances, and yet minimize visual impact.

TOWER EVALUATION

Crown Castle (the WCF owner) has presented an engineered study and recommends a ten (10) foot height extension to be added to the existing 110’ AGL height.

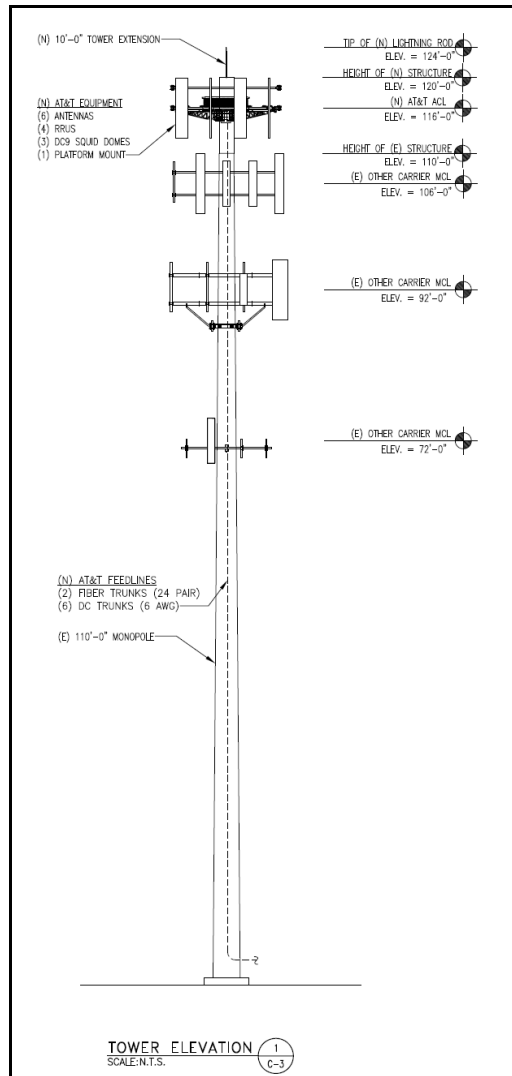
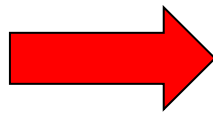

This tower structure, as proposed, would allow room for co-location of at least 3 wireless carriers on the same site, minimizing the number of towers needed for all wireless telecommunications carriers to eventually optimize service in this area. The tower currently has two Digital cellular co-locators and one (1) Wireless Internet Service Provider. This proposal will make #3 digital cellular carriers. This tower design has a long service life, and has been designed with the ability to support additional appurtenances as built.

ANALYSIS

Crown Castle, the tower owner and operator, provided a structural analysis for the overall tower extension. This evaluation was performed using the current structural standards of the EIA 222-G. This evaluation for the existing tower and

extension was performed by Crown Castle, Inc. in a report dated April 1, 2021 by Mr. Terry P. Styran, PE.

The tower was determined to be classified with “**Sufficient Capacity.**”

Date: April 1, 2021

CROWN CASTLE
Crown Castle
2000 Corporate Drive
Canonsburg, PA 15317
(724) 416-2000

Subject: Structural Modification Report

Carrier Designation: AT&T Mobility Co-Locate
Site Number: 298359
Site Name: Arcadia Farms

Crown Castle Designation: BU Number: 826603
Site Name: Perry - Berryville
JDE Job Number: 620891
Work Order Number: 1938086
Order Number: 530446 Rev 1

Engineering Firm Designation: Crown Castle Project Number: 1938086

Site Data: 4163 Harry Byrd Highway, Berryville, Clarke County, VA
Latitude 39° 7' 47.3", Longitude -77° 54' 50.1"
119 Foot - Monopole Tower

Crown Castle is pleased to submit this "Structural Modification Report" to determine the structural integrity of the above-mentioned tower.

The purpose of the analysis is to determine acceptability of the tower stress level including the proposed modifications as outlined in the attached drawings, "Appendix D". Based on our analysis we have determined the tower stress level for the structure and foundation, under the following load case, to be:

LC4: Modified Structure with Considered + Proposed Equipment Configuration **Sufficient Capacity**

This analysis utilizes an ultimate 3-second gust wind speed of 115 mph as required by the 2015 Virginia Construction Code. Applicable Standard references and design criteria are listed in Section 2 - "Analysis Criteria"

Structural analysis prepared by: Matthew Belts

Respectfully submitted by:

Terry P. Styran, P.E.
Senior Project Engineer



Terry P. Styran
2021.04.01
16:52:56 -04'00'



MOUNT EVALUATION

As proposed at the 120' AGL position, AT&T intends to provide current and future placement of twelve (12) "standard installed" panel antennas with a vertical length of ten (10) feet each and 150 feet of associated 7/8" transmission lines on this tower. At the base of the tower, a 12' x 20' concrete pad will support a 6' x 6' equipment hut with some low-profile equipment cabinets, which will house all of the telecommunications equipment installed by the Applicant. The entire 70' x 70' compound will continue to be enclosed by an 8' high chain-link security fence with 1' barbed wire extension (total of 9' in height), which will prevent unauthorized access to the tower and applicant's equipment, but will allow sufficient room for additional co-location if such expansion is ever requested.

AT&T Antenna Mount Plan

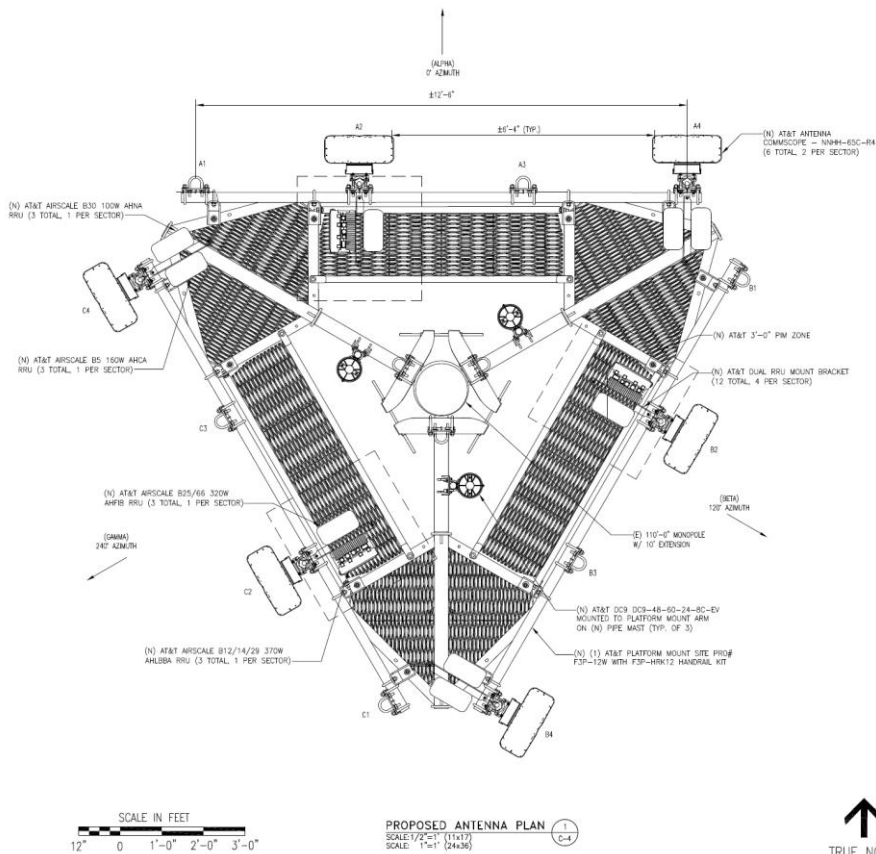

ANALYSIS

The second Structural Analysis was performed for the addition of antennas, cables and devices to the platform. This is known as a **“Mount Analysis.”**

This evaluation was performed by the engineering firm of Tower Engineering Professionals, Inc by Mr. Jordan W. Shelley, PE. This evaluation also used the current EIA 222-G evaluation criteria for the Mount and was rated **“Sufficient Capacity”**.

February 22, 2021

Darcy Tarr
Crown Castle
3530 Toringdon Way, Suite 300
Charlotte, NC 28277
(704) 405-6589

Tower Engineering Professionals
326 Tryon Road
Raleigh, NC 27603
(919) 661-6351
CrownMA@tepgroup.net

Subject: Mount Analysis

Carrier Designation: AT&T Mobility Co-Locate
Client Site Number: 298359
Client Site Name: Arcadia Farms
FA Location Code: 15372477

Crown Castle Designation: Crown Castle BU Number: 826603
Crown Castle Site Name: Perry - Berryville
Crown Castle JDE Job Number: 620891
Crown Castle Order Number: 530446 Rev. 0

Engineering Firm Designation: TEP Project Number: 68263.504876

Site Data: 4163 Harry Byrd Highway, Berryville, Clarke County, VA 22611
Latitude 39° 7' 47.30", Longitude -77° 54' 50.10"

Structure Information: Tower Height & Type: 110.0± ft Monopole w/Proposed 10ft Extension
Mount Elevation: 116.0 ft
Mount Width & Type: 12.5 ft Platform w/ Support Rail

Dear Darcy Tarr,

Tower Engineering Professionals is pleased to submit this "Mount Analysis" to determine the structural integrity of AT&T Mobility's antenna mounting system with proposed appurtenance and equipment addition on the above mentioned supporting tower structure. Analysis of the existing supporting tower structure is to be completed by others and therefore is not part of this analysis. Analysis of the antenna mounting system as a tie-off point for fall protection or rigging is not part of this document.

The purpose of the analysis is to determine acceptability of the mount stress level. Based on our analysis, we have determined the mount stress level to be:

Platform w/ Support Rail Mount	Sufficient Capacity
---------------------------------------	----------------------------

The analysis has been performed in accordance with the 2018 [International Building Code](#) based upon an ultimate 3-second gust wind speed of 111 mph. Applicable Standard references and design criteria are listed in Section 2 - Analysis Criteria.

Structural analysis prepared by: G. Hunter Morrow, E.I.

Respectfully submitted by:

Jordan W. Shelley, P.E.
Structural Division Manager
919-661-6351
ishelley@tepgroup.net

 02/22/2021

Furthermore, in conformance with County ordinance, work at this site will remain in compliance with ALL federal, state, and local building codes and regulations if work proceeds as outlined in the application.

1.3 RF Exposure

FCC bulletin OET-65 provides guidance for a licensee proposing to construct a telecommunications support structure in calculation of RF exposure limitations, including analysis of the cumulative effect of all transmitters on the structure. Appropriate steps, including warning signage at the site, must be taken to protect both the general public and site workers from unsafe RF exposure in accordance with federal guidelines.

The consultant sees no evidence of unsafe RF exposure levels being generated at this site if construction were to proceed as proposed. RF site exposure warning signage placement is appropriately planned for this site.

1.4 Grounding

Grounding of all structures and equipment at an RF site is critically important to the safety of both personnel and equipment at the site. Even a single component not meeting these standard places all other site components at risk for substantial damage. All structures and equipment at the site should maintain a ground potential difference of less than 5 ohms.

Grounding Notes: (Included on Drawings)

<u>GROUNDING NOTES</u>	
1.	1. GROUNDING SYSTEM RESISTANCE SHALL NOT EXCEED 5 OHMS, PRE MEG AND POST MEG REQUIRED. IF THE RESISTANCE VALUE IS EXCEEDED, NOTIFY THE OWNER FOR FURTHER INSTRUCTION ON METHODS FOR REDUCING THE RESISTANCE VALUE. CONTRACTOR SHALL SUBMIT TO THE PROJECT MANAGER ALL TEST REPORTS AND ONE COMPLETE SET OF PRINTS SHOWING "INSTALLED WORK". AT&T CONSTRUCTION MANAGER MUST BE NOTIFIED OF COMPLETION OF GROUNDING SYSTEM INSTALLATION, PRIOR TO COVERING, TO SCHEDULE INSPECTION OF INSTALLATION (24 HOUR MINIMUM NOTICE MUST BE GIVEN TO CONSTRUCTION MANAGER FOR SCHEDULING).
2.	UPON COMPLETION OF WORK, CONDUCT CONTINUITY, AND FALL POTENTIAL GROUNDING TESTS FOR APPROVAL. SUBMIT TEST REPORTS TO PROJECT MANAGER. CLEAN PREMISES OF ALL OF ALL DEBRIS RESULTING FROM WORK AND LEAVE WORK IN A COMPLETE AND UNDAMAGED CONDITION.
3.	ALL EXPOSED GROUND WIRES ROUTED ALONG THE SIDE OF EQUIPMENT CABINETS OR ROUTED OVER CONCRETE FOUNDATIONS OR OTHER EXISTING STRUCTURES SHALL BE INSTALLED IN PROPERLY ANCHORED 1/2" (MIN.) SILICONE FILLED SEAL TIGHT CONDUIT.
4.	CONTRACTOR SHALL NOT DISTURB EXISTING GROUNDING SYSTEM. ANY DAMAGE SHALL BE REPAIRED IMMEDIATELY AT NO ADDITIONAL COST.
5.	ALL ELEMENTS OF ICE BRIDGE AND AT&T UTILITY BACKBOARD MUST BE BONDED AND JUMPERED TO GROUNDED COMPONENTS OF THESE SYSTEMS.
6.	ALL INTERIOR CABLES AND WIRING SHALL BE NEATLY ROUTED IN OVERHEAD LADDER RACK AND FASTENED TO LADDER RACK WITH WAX COATED STRING PER LUCENT TECHNOLOGIES INSTALLATION STANDARDS. PLASTIC CABLE TIES SHALL NOT BE USED.
7.	ALL GROUNDING CONDUCTORS SHALL BE ROUTED DOWNWARDS FROM POINT OF ORIGIN TO TERMINATION POINT (GROUND BAR, GROUND RING, ETC.). CONNECTIONS TO OVERHEAD HOLLOW GROUND SHALL BE THE ONLY EXCEPTION.
8.	GROUNDING CONDUCTORS SHALL NOT REVERSE DIRECTION (EXCEPT HOLLOW AND BURIED GROUND RINGS). OTHER EXCEPTIONS NEED TO BE APPROVED BY AT&T PROJECT MANAGER PRIOR TO INSTALLATION.
9.	USE OF 90° BENDS IS PROHIBITED, MAXIMUM ALLOWED BENDING RADIUS OF PROTECTION GROUNDING CONDUCTORS IS 45°.
10.	ANY FENCE WITHIN 7' OF ANY AT&T EQUIPMENT (EQUIPMENT CABINETS, GENERATOR, FUEL TANK, ICE BRIDGE, ETC.) SHALL BE BONDED TO THE AT&T EQUIPMENT CABINETS GROUND RING OR COMPOUND GROUND RING.
11.	AT&T EQUIPMENT CABINETS GROUND RING SHALL BE BONDED TO TOWER AND COMPOUND GROUND RINGS IN 2 PLACES EACH.
12.	IN ACCORDANCE WITH NEC 2014 REQUIREMENTS, ALL GROUNDING ELECTRODES PRESENT ON SITE SHALL BE BONDED TOGETHER (REFERENCE 2014 NEC ARTICLE 250.50)
<u>NOTES</u>	
1.	BOND ANTENNA GROUNDING KIT CABLE TO GROUND BAR (GND BAR)
2.	HALO GROUND DESIGNED AND INSTALLED BY SHELTER MANUFACTURER. TIE INTO EGR IN 6 LOCATIONS
3.	ALL CELL EQUIPMENT (BITS, BATTERY FRAME, POWER CABINETS, MISC. EQUIPMENT FRAMES, ETC.) SHALL BE GROUNDED IN ACCORDANCE WITH MANUFACTURER SPECIFICATIONS AND INSTALLED BY WIC VENDOR
4.	GROUND BAR AT BASE OF TOWER ONLY REQUIRED WHEN COAX IS USED
5.	GROUND METER PER N.E.C. STANDARDS
6.	GROUND ALL EQUIPMENT PER AT&T SPECIFICATIONS AND NEC
7.	GROUND EXISTING FENCE POSTS WITHIN 7' OF PROPOSED EQUIPMENT

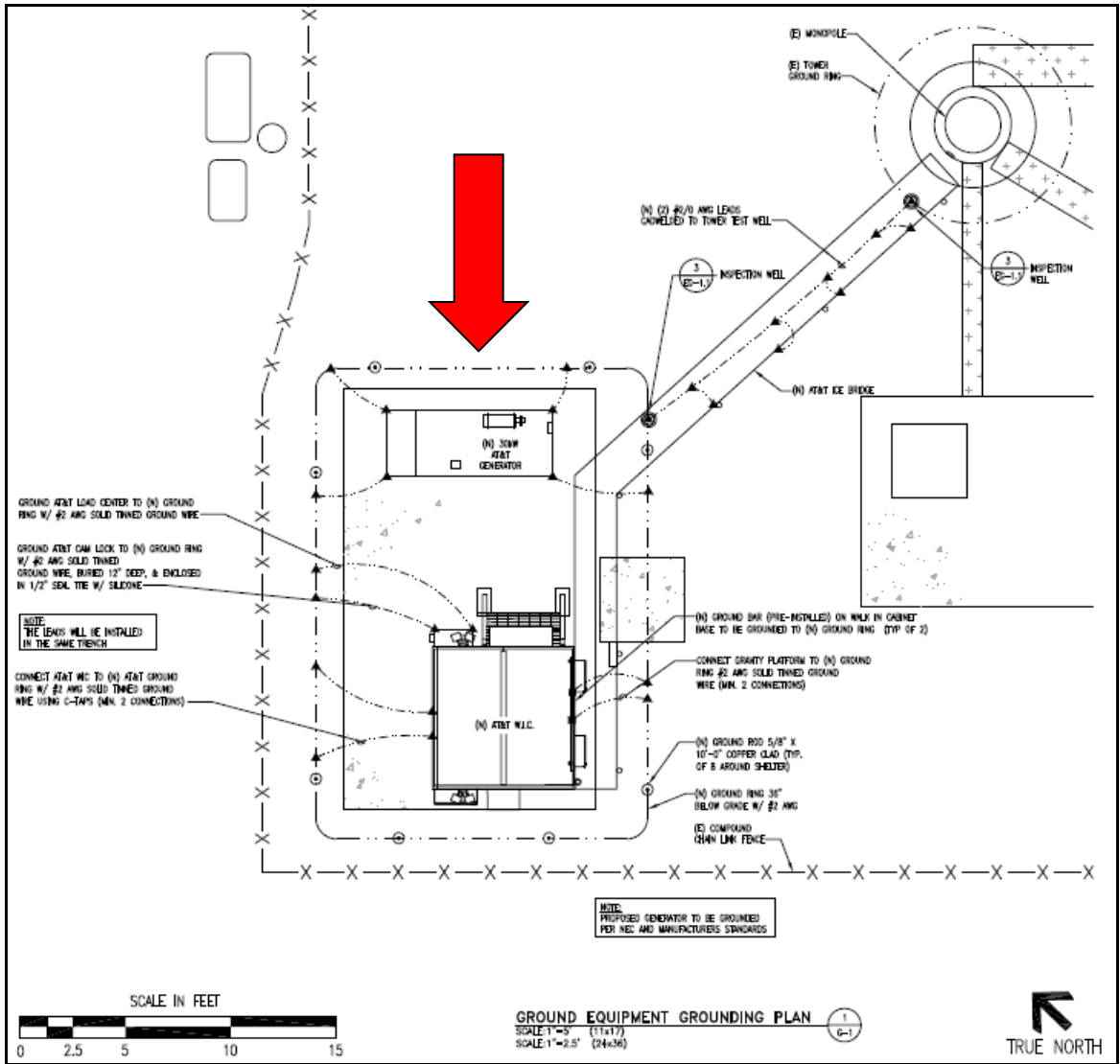

If the construction is performed as proposed, sufficient grounding will be maintained at this site. Detailed Grounding Plans must be submitted and reviewed and address this issue.

1.5 General Safety

As clearly indicated in the proposed site plans, this site compound will be surrounded by suitable security fencing. Additional safety measures to be placed at this site include RF exposure warning signage, site identification information, and routine and emergency contact information. The site plans should include the installation of an OSHA-approved style of fall prevention cable.

1.6 Interference

An interference study, taking into account all proximally located transmitters and receivers known to be active in the area are advisable prior to any new tower construction. This is not necessary for a co-location on an existing tower.

This consultant sees no evidence of interference by or with this site after a general evaluation of the surrounding transmitter sites.

Should any interference issues be posed with respect to this site, mitigation would nevertheless remain the responsibility of the tower owner and affected carrier(s), and would be regulated by the Federal Communication Commission, having no effect or burden on the County.

2.0 PROCEDUREAL

2.1 FAA Study : TOWAIR

An initial search was performed by this consultant via TOWAIR Determination under the ASR online system on the FCC website to determine if registration is a requirement.

The results of the TOWAIR Determination search were as follows: "A routine check of the coordinates, heights, and structure type you provided indicates that this structure does NOT require registration."

TOWAIR Determination Results

*** NOTICE ***

TOWAIR's findings are not definitive or binding, and we cannot guarantee that the data in TOWAIR are fully current and accurate. In some instances, TOWAIR may yield results that differ from application of the criteria set out in 47 C.F.R. Section 17.7 and 14 C.F.R. Section 77.13. A positive finding by TOWAIR recommending notification should be given considerable weight. On the other hand, a finding by TOWAIR recommending either for or against notification is not conclusive. It is the responsibility of each ASR participant to exercise due diligence to determine if it must coordinate its structure with the FAA. TOWAIR is only one tool designed to assist ASR participants in exercising this due diligence, and further investigation may be necessary to determine if FAA coordination is appropriate.

DETERMINATION Results

Structure does not require registration. There are no airports within 8 kilometers (5 miles) of the coordinates you provided.

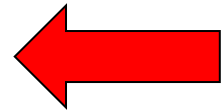

Your Specifications

NAD83 Coordinates

Latitude	39-07-47.8 north
Longitude	077-54-50.1 west

Measurements (Meters)

Overall Structure Height (AGL)	36.6
Support Structure Height (AGL)	NaN
Site Elevation (AMSL)	153.3

Structure Type

MTOWER - Monopole

2.2 FCC Antenna Site Registration

This site does not yet have, and is not required to have, an antenna site registration number.

It is recommended by the consultant that this site be registered with the Federal Communication Commission.

All registered sites should have their registration number conspicuously displayed at the site, normally on the security fence surrounding the compound area.

2.3 Environmental Impacts

The National Environmental Policy Act of 1969 (NEPA), delineated in Title 47 of the Code of Federal Regulations, Part 1, Subpart I, sections 1.1301-1.1319, requires federal agencies to incorporate environmental considerations into their decision-making process when evaluating new construction proposals. As a licensing agency, the Federal Communication Commission (FCC) requires all licensees to consider the potential environmental effects from their construction of antenna support structures, and to disclose those effects in an Environmental Assessment (EA) that must be filed with the FCC for review.

The Applicant possesses a copy of the FCC NEPA Summary Report if review is desired.

2.4 Historic Impacts

Section 106 of the National Historic Preservation Act of 1966 (NHPA) requires that State Historic Preservation Offices (SHPO) and the President's Advisory Council on Historic Preservation be given a reasonable opportunity to comment on all undertakings with the potential to affect historic properties. The licensee is required to submit to the SHPO a detailed description of the project, a listing of local historic resources, and a discussion of any measures being undertaken to mitigate impacts (if any) on historic resources. Upon receipt, the SHPO has thirty (30) days to review and respond to those submissions. All agencies with authority to permit construction are required to consider the SHPO response in its decision-making process with respect to new construction applications.

The Applicant possesses a copy of the State Historic Preservation Offices Report if review is desired.

2.5 Co-location

The coverage objective for this tower is the south and north sides of US Rt. 7 Harry Byrd Highway.

Two Existing wireless providers, Verizon and T-Mobile are currently co-located on this structure. By approving the 10' extension will prevent another tower from being built nearby to cover this geographic area. The bottom 3rd Slot is occupied by a Wireless Internet Service Provider.

3.0 RECOMMENDATIONS

AT&T is an FCC licensed telecommunications provider authorized to provide digital wireless service to the Clarke County area in conjunction with Crown Castle and proposes the addition of a ten (10) foot height extension of a Class 3 Wireless Communications Facility (WCF) 110' monopole style tower to support service delivery in an area with a lack of AT&T coverage in the Harry Byrd (Rt. 7) Highway.

It is the opinion of this consultant that the application conforms to all of the County's Design Standards regarding the construction and co-location of telecommunications support structures outlined in the current ordinance for Wireless Communications Facilities and should be approved.

Respectfully submitted,

A handwritten signature in cursive script that reads "George N. Condyles, IV".

George N. Condyles, IV, CPM
President & COO

CLARKE COUNTY
LAND DEVELOPMENT APPLICATION



Applicant AT&T @ Arcadia Farms
 Applicant's Address 4163 Harry Byrd Highway
 Berryville VA 22611
 City State Zip Code
 Applicant's E-Mail Address eogrady@nbcllc.com
 Agent (Contact Person) Emily O'Grady Phone 862-266-2029
 Agent's Company AT&T (c/o NB+C)
 Agent's Address 6095 Marshalee Dr. Ste 300 Elkrdige, MD 21075
 Current Property Owner Perry Stuart M Inc
 Owner's Address 117 Limestone Lane Winchester, VA 22602 Phone 862-266-2029
 Correspondence to be sent to: Applicant Owner Agent Other
 Tax Map Parcel Number 16 A 33 Magisterial District _____
 General Project Location Qaurry Rd. & Harry Byrd Hwy Site size (gross/net acreage) 149

Check Appropriate Request:

PLANNING COMMISSION

- Major Subdivision
- Minor Subdivision (1 or 2 lots)
- Administrative Subdivision (parcels > 100 acres)
- Boundary Line Adjustment
- Site Plan
- Site Plan Amendment
- Erosion & Sediment Plan
- Storm Water Plan
- Maximum Lot Size Exception

PLANNING COMMISSION & BOARD of SUPERVISORS

- Rezoning
- Special Use Permit
- Comprehensive Plan Amendment
- Zoning Ordinance Text Amendment
- Subdivision Ordinance Text Amendment
- Other

BOARD OF ZONING APPEALS

- Administrative Appeal
- Variance
- Special Exception

BOARD OF SEPTIC & WELL APPEALS

- Administrative Appeal
- Variance

BERRYVILLE AREA DEVELOPMENT AUTHORITY

- Site Plan
- Site Plan Amendment

HISTORIC PRESERVATION COMMISSION

- Certificate of Appropriateness

Complete as applicable:

Name of Subdivision, Development, or Proposal AT&T @ Arcadia Farms
 Proposal/Request Carrier add to existing monopole. Consisting of 10 foot tower extension and additional antennas, rru's, generator and ancillary equipment.
 Existing Zoning _____ Proposed Zoning _____ # of Proposed Lots _____

Applicant: The information provided is accurate to the best of my knowledge. I acknowledge that any percolation tests, topographic studies, or other requirements of the Health Official or Zoning Administrator will be carried out at my expense. I understand that the County may deny, approve, or conditionally approve that for which I am applying. I certify that all property corners have been clearly staked and flagged. Applicant's Signature  Date 06/22/2021

Owner: I have read this completed application, understand its intent, and freely consent to its filing. If this application is for the purpose of subdivision, I understand that further subdivision of this property will not be permitted within twelve (12) months of approval of this action, unless an Exploratory Sketch Plan is submitted with this application. Furthermore, I grant permission to the Planning Department and other authorized government agents to enter the property and make such investigations and test as they deem necessary. Owner's Signature _____ Date _____

101 Chalmers Court
 Berryville, VA 22611

www.clarkecounty.gov

(540) 955-5132
 Fax (540) 955-5180

THIS PAGE IS FOR OFFICE USE ONLY.

Application Received by: _____ Date _____
Receipt No. _____
Date Application Complete: _____

Recommending/Approving Authority:

	Public Hearing	Recommendation	Approval
_____ Staff	_____	_____	_____
_____ Planning Commission	_____	_____	_____
_____ Board of Supervisors	_____	_____	_____
_____ Septic & Well Appeals	_____	_____	_____
_____ Board of Zoning Appeals	_____	_____	_____
_____ Historic Pres. Commission	_____	_____	_____

Proposed Lot Configuration: (Boundary Line Adjustments, and Subdivisions)

RE: Crown Castle/AT&T
Site: 826603/Arcadia Farms
Perry-Berryville
4163 Harry Byrd Highway
Berryville, VA 22611

Please accept the enclosed application and materials on behalf of Crown Castle with AT&T. Network Building + Consulting is representing Crown Castle in its application to modify an existing wireless telecommunications facility at 4163 Harry Byrd Highway.

Crown Castle is a real estate investment company that provides shared communications infrastructure in the United States. Its network includes 40,000 cellular towers and 80,000 route miles of fiber supporting small cells and fiber solutions. AT&T is a national provider of wireless telecommunications services, operating consumer voice and data networks pursuant to exclusive licenses from the Federal Communications Commission (FCC).

Crown castle is proposing a 10ft tower extension to the existing 110ft tower located on the property identified above. AT&T will install and replace new antennas and ancillary equipment on and inside the already existing structure and fenced compound.

Please feel free to contact me with any questions, concerns, or requests for more information.

Emily O'Grady
Site Acquisition Associate
Network Building + Consulting

eogrady@nbcllc.com
(862)266-2029

STATEMENT IN SUPPORT OF SPECIAL EXCEPTION

AT&T has identified a need for expanded coverage and capacity in Clarke County, Virginia. Crown Castle, in partnership with AT&T, is proposing a 10-foot tower extension to serve this need at the following location:

Address: 4163 Harry Byrd Highway

Parcel: 16 A 33

The parcel is a 149-acre lot, already containing an existing telecommunications facility, owned by Perry Stuart M. Inc. Crown castle would construct a 10-foot tower extension. AT&T's antennas would be place at 116ft and ground equipment would be placed inside of the existing compound.

The public has an interest in robust and complete network service, both for public safety and for convenience and general welfare. The FCC currently estimates that more than 70% of 9-1-1 calls are placed from mobile devices, and that percentage is expected to grow. Additionally, mobile devices account for over 55% of all internet traffic. More than 75% of "smartphone" owners use mobile data for navigation, a service which is used by utility companies, transportation services, and the general public.

AT&T's antennas and equipment will serve Clarke County, supporting local uses of its data and voice networks for public service, commerce, and communication. Telecommunications carriers must locate antenna sites according to a network design within limited geographic parameters. Signal loss from areas unserved by the network create service disruptions. Such incomplete systems are not consistent with carriers' requirements to provide continues coverage as defined by their FCC licenses.

Crown Castle submits and respectfully requests Clarke County grant this appeal for Special Exception to establish a tower extension at the facility, for the Use of AT&T and any future collocators.

STATEMENT OF NEED

AT&T has identified this area as underserved on its voice and data networks within an area it served under its exclusive FCC licenses. The extension of this site would allow AT&T to increase coverage in area of Clarke County, Virginia. AT&T is required by its FCC licenses to provide continuous coverage in its marker areas to increasing percentage of the population within certain timeframes. There are no other viable candidates in the search radius.

RECITATIONS AND REQUESTS

The following are hereby incorporated into this application. To the best of the Applicant’s knowledge and belief, the Applicant hereby states and or/requests the following:

1. All information in this application and accompanying materials is, to the best knowledge of the applicant, true and complete.
2. The proposed Wireless Telecommunications Facilities shall be maintained in a safe manner, and in compliance with all conditions of the Special Use Permit, without exception, unless specifically granted relief by the County in writing, as well as all applicable and permissible local codes, ordinances, and regulations, including any and all applicable County, State, and Federal Laws, rules, and regulations.
3. The construction of the Wireless Telecommunications Facilities is legally permissible, including, but not limited to the fact that the Applicant is authorized to do business in the State.
4. The proposal is a modification of an existing Wireless Telecommunication Facilities site, and all work associated with the proposal will be contained to within the existing compound. The existing compound footprint will not be expanded.
5. The site has existing utility service. No utility service will be added to the site as a result of the proposal.
6. The site has an existing access road. The proposal will not result in the addition of a new access road.
7. The existing and proposed extension is under 200 feet in height and does not require any lighting.
8. All required RF signage will be installed before construction begins. For any required RF signage not currently installed at the site at the date of application the Applicant hereby requests that this requirement is deferred until that time.
9. The proposal is a modification and extension of an existing Wireless Telecommunications Facilities site and will not alter the setbacks of the existing site.

APPLICABLE SECTIONS OF CLARKE COUNTY ZONING ORDINANCE

All requirements are as determined on the pre-application call of Friday, 05/28/2021, or in subsequent correspondence, as noted.

Code Section/Compliance Item	Item is addressed by ...
------------------------------	--------------------------



6-A: INTENT	Statement is included in the cover letter
6-B-1: Site Plan shall be submitted in accordance with this article for all proposed buildings, structures, or uses...	Exhibit B (page C-1)
6-E-1: Pre-Application Conference Requirement	conducted with Jeremy Camp 5/28/2021
6-E-2: Application	Application and Drawings submitted 06/22/2021
6-G-1: The proposed title of the project and the name of the engineer, architect, landscape-architect or surveyor; the name of the developer; name and address of the property owner	Project Title: AT&T @ Arcadia Farms Engineer: Christopher D. Morin Architect & Surveyor: N/A Property Owner: Perry M. Stuart Inc. 117 Limestone Lane Winchester, VA 22602
6-G-3: Signature of Property Owner	Exhibit F
6-G-4: North Point, scale, and date	Exhibit A (page C-1) and Exhibit B (page C-1)
6-G-5: Vicinity map at a scale of one-inch equals not more than 2,000 feet, showing the location of the project in relation to state roads and other prominent features.	Exhibit A (page C-1)
6-G-6: Existing zoning and zoning district boundaries for the property in question, and on immediately surrounding properties.	Zoning AOC Exhibit A (page T-1 and C-1)
6-G-7: The present owner and use of all properties contiguous or directly across any street	Exhibit A (page C-1)
6-G-8: The boundaries of the property involved by bearings and distances, certified by a land surveyor licensed to practice in the Commonwealth of Virginia.	Exhibit B and Exhibit A (page C-1)
6-G-9: All existing property lines, existing streets, buildings, watercourses, waterways, lakes, and other existing physical features on or adjoining the property. Size and height of existing buildings on the property should be shown. Features on adjoining properties need only be shown in approximate scale and proportion.	Exhibit A (page C-1)
6-G-10: Topography of the project area with contour intervals of two feet or less	Exhibit G and Exhibit B (page C-2)



<p>6-G-11: Location and sizes of sanitary and storm sewers, gas lines, water lines, culverts, fire hydrants, and other above-ground or underground structures in or affecting the project, including existing and proposed facilities, and easements for these facilities.</p>	<p>Exhibit A (page C-1)</p>
<p>6-G-12: The location, dimensions, name, and construction details (including typical sections) of proposed streets, alleys, driveways, and the location, type, and size of ingress and egress to the site. When proposed streets intersect with existing streets, both edges of existing pavement or curb and gutter must be indicated for a minimum of 50 feet or the length of connections, whichever is greater</p>	<p>Exhibit B (page C-1)</p>
<p>6-G-14: The location, height, type, and material of all fences, walls, screen planting, and landscaping details of all buildings and grounds, and the location, height, and character of all outdoor lighting systems</p>	<p>Exhibit B (page C-1)</p>
<p>6-G-15: The location of all proposed buildings and structures, primary and accessory; number of stories and height; proposed general use of each structure; and the number, size, and type of dwelling units, where applicable.</p>	<p>Exhibit B (page C-1)</p>
<p>6-G-19: Flood plain studies as required by the Agent</p>	<p>Exhibit H - location not in flood plains</p>
<p>6-G-20: The location, size, height, materials used, orientation, and illumination of proposed signs</p>	<p>N/A - Not proposing any new signs except what is required by FCC for security and equipment identification. Any required signs will be located within the compound and will not be visible from public ways.</p>
<p>6-G-22: The location of all wooded areas on the site, including all individual large or medium canopy trees (see section 6-H-10-g) with a diameter of eight inches or more (measured 4½ feet above the ground) and all small canopy trees (see section 6-H-10-g) with a diameter four inches or greater (measured 4½ feet above the ground) that are located within the areas proposed for clearing and within 20 feet of the proposed limit of clearing. The site plan shall provide an indication of which trees are to be retained and which are to be removed.</p>	<p>Exhibit B (page C-2)</p>

6-G-25: Building restriction lines.	Exhibit A (page C-1)
6-G-26: Distance to nearest school or school site.	Exhibit I
6-G-27: Elevation plans for all exterior facades of proposed structures, showing design features and indicating materials and colors to be used.	Exhibit A
6-G-29: Total site acreage; acreage of individual lots and street rights-of-way	Exhibit A (page C-1), Exhibit B (page C-2)
6-G-33: Maximum number of employees anticipated, if industrial, commercial, or office; net density of dwelling units, if residential.	N/A - unmanned site. Maximum traffic is 4 visits a month.
6-G-35: Anticipated daily vehicle trips generated by the site development based upon data found in Trip Generation, by the Institute for Transportation Engineers, latest edition; capacity of existing and proposed streets; sight distances for all intersections based on Virginia Department of Transportation (VDOT), "Road Design Manual and Minimum Standard of Entrances" to state highways, latest edition; proposed improvements within existing street rights-of-way; and, further traffic studies as required by the Agent. If additional traffic studies are required, the applicant shall use the applicable criteria and methodologies found in the VDOT Design Manual, latest edition. The Agent may assign all or a part of the VDOT "Guidelines for a Traffic Impact Study" depending on the type, size, and location of the development.	N/A - unmanned site. Maximum traffic is 4 visits a month.
6-G-38: Bond estimates for all required improvements	Exhibit D
6-G-39: Any necessary notes required by the Agent to explain the purpose of specific items on the plan.	Statement is included in the cover letter
6-G-40: Additional information as deemed necessary by the Administrative Body or the Agent.	Statement is included in the cover letter.

LIST OF EXHIBITS

Exhibit	Item
A	Construction Drawings
B	Site Plan
C	Structural Analysis
D	Removal Bond Memo
E	Mount Analysis
F	Lease
G	Topography Map
H	Flood Plains Map
I	Map to Nearest Education Facility

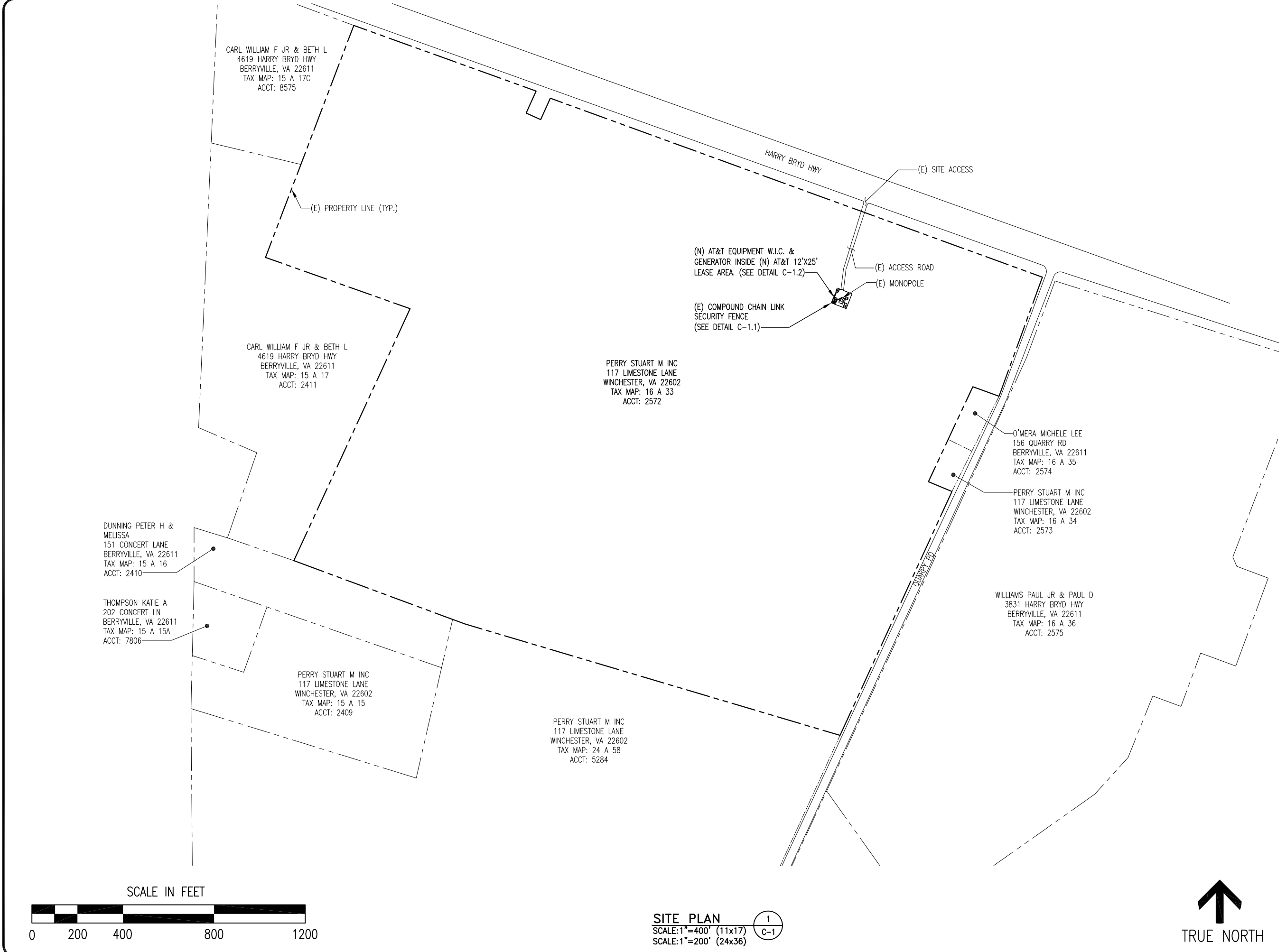

SITE PLAN
 SCALE: 1"=400' (11x17)
 SCALE: 1"=200' (24x36)

1
 C-1



575 MOROSGO DRIVE
 ATLANTA, GA 30324-3300

3530 TORINGDON WAY, SUITE 300
 CHARLOTTE, NC 28277

5661 COLUMBIA PIKE, SUITE 200
 FALLS CHURCH, VA 22041-2868

AT&T FA#: 15372477
ARCADIA FARMS

 CROWN BU#: 826603
PERRY - BERRYVILLE

 4163 HARRY BYRD HIGHWAY
 BERRYVILLE, VA 22611

 EXISTING 110'-0" MONOPOLE
 WITH PROPOSED
 10'-0" EXTENSION

ISSUED FOR:

REV	DATE	DRWN	DESCRIPTION	DES./QA
A	03/20/21	MM	PRELIMINARY	SS/BMQ
0	04/30/21	SS	FINALS	SS/BMQ
1	05/14/21	SS	FINALS	SS/BMQ
2	06/28/21	SS	FINALS	SS/BMQ

COMMONWEALTH OF VIRGINIA
 CHRISTOPHER D. MORIN
 No. 032984
 6.28.21
 PROFESSIONAL ENGINEER

IT IS A VIOLATION OF LAW FOR ANY PERSON,
 UNLESS THEY ARE ACTING UNDER THE DIRECTION
 OF A LICENSED PROFESSIONAL ENGINEER,
 TO ALTER THIS DOCUMENT.

SHEET NUMBER: C-1	REVISION: 2
-----------------------------	-----------------------



575 MOROSGO DRIVE
ATLANTA, GA 30324-3300



3530 TORINGDON WAY, SUITE 300
CHARLOTTE, NC 28277



5661 COLUMBIA PIKE, SUITE 200
FALLS CHURCH, VA 22041-2868

AT&T FA#: 15372477
ARCADIA FARMS

CROWN BU#: 826603
PERRY - BERRYVILLE

4163 HARRY BYRD HIGHWAY
BERRYVILLE, VA 22611

EXISTING 110'-0" MONOPOLE
WITH PROPOSED
10'-0" EXTENSION

ISSUED FOR:

REV	DATE	DRWN	DESCRIPTION	DES./QA
A	03/20/21	MM	PRELIMINARY	SS/BMQ
0	04/30/21	SS	FINALS	SS/BMQ
1	05/14/21	SS	FINALS	SS/BMQ
2	06/28/21	SS	FINALS	SS/BMQ

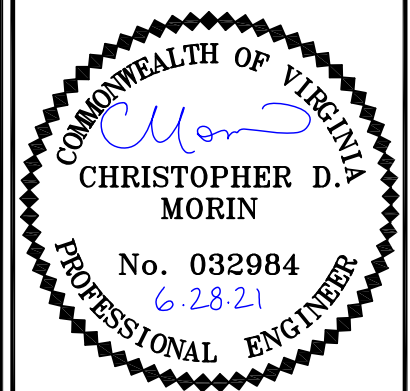

IT IS A VIOLATION OF LAW FOR ANY PERSON,
UNLESS THEY ARE ACTING UNDER THE DIRECTION
OF A LICENSED PROFESSIONAL ENGINEER,
TO ALTER THIS DOCUMENT.

SHEET NUMBER: REVISION:

C-3 2

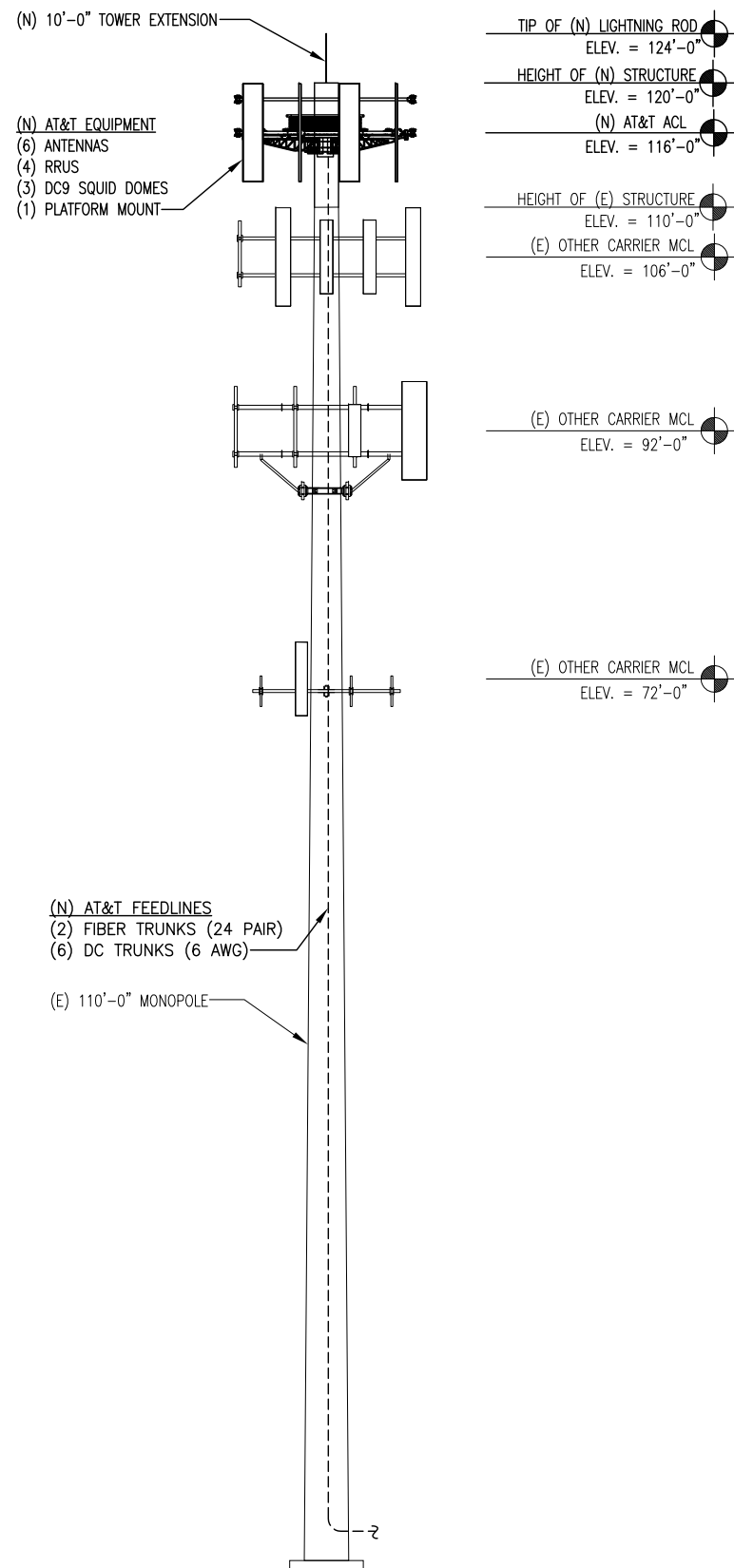

TOWER ELEVATION 1
SCALE: N.T.S. C-3

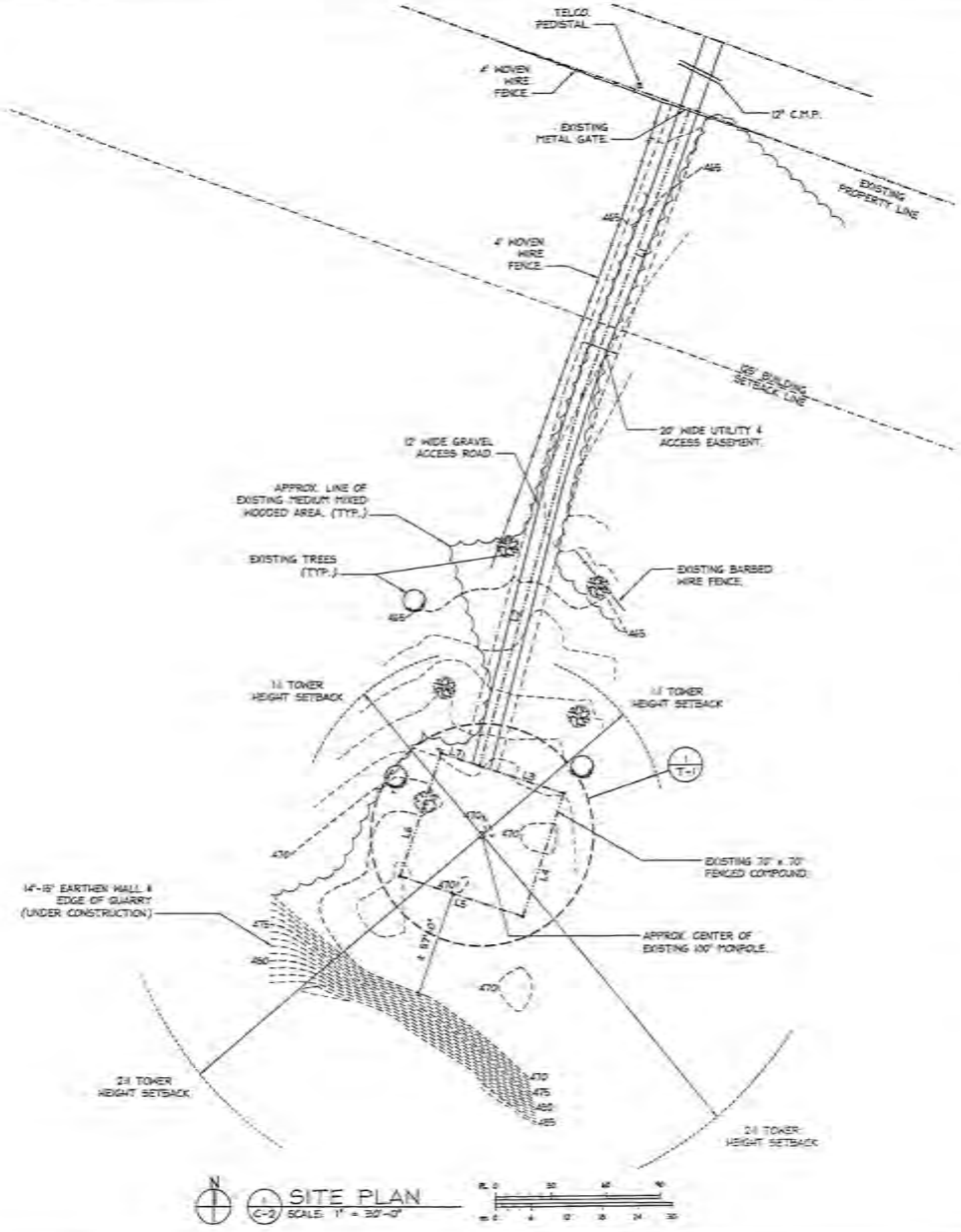

PROP. OWNERS LIST

Acct# 000002574 COUNTY OF CLARKE
 Owner/Name Address Adr. Chr. Status
 WYFFORD, FRANK R & ADA C PARRERA
 133 QUARRY ROAD
 BERRYVILLE VA 22611 0000
 EDC: CDA
 Desc: -11 ON RT 7
 Desc: -11 ON RT 7
 Desc: -11 ON RT 7
 Area P&G 18 382 DC A B&L LOT 35
 OFFS: REPARTED

Acct# 000002573 COUNTY OF CLARKE
 Owner/Name Address Adr. Chr. Status
 PERRY, SYDNEY K INC
 111 WINSTON LANE
 WINCHESTER VA 22602 0000
 EDC: CDA
 Desc: -11 ON RT 7
 Desc: -11 ON RT 7
 Desc: -11 ON RT 7
 Area P&G 18 382 DC A B&L LOT 24
 OFFS: REPARTED

Acct# 000002572 COUNTY OF CLARKE
 Owner/Name Address Adr. Chr. Status
 PERRY, SYDNEY K INC
 111 WINSTON LANE
 WINCHESTER VA 22602 0000
 EDC: CDA
 Desc: -11 ON RT 7
 Desc: -11 ON RT 7
 Desc: -11 ON RT 7
 Area P&G 18 382 DC A B&L LOT 33
 OFFS: REPARTED

Acct# 000002575 COUNTY OF CLARKE
 Owner/Name Address Adr. Chr. Status
 HARRIS, WARDEN P
 1833 HARRY BYRD HIGHWAY
 BERRYVILLE VA 22611 0000
 EDC: CDA
 Desc: -11 ON RT 7
 Desc: -11 ON RT 7
 Desc: -11 ON RT 7
 Area P&G 18 382 DC A B&L LOT 36
 OFFS: REPARTED

NOTES

- REFER TO SHEET C-1 FOR ZONING INFORMATION, SURVEY INFORMATION, AND SURVEY NOTES.
- REFER TO SHEET C-1 FOR ADJACENT PROPERTY LOCATIONS IN RELATION TO THIS PARCEL.
- REFER TO SHEET T-1 FOR EQUIPMENT NEW & EXISTING EQUIPMENT LAYOUT.

PROPERTY LINE TABLE

LINE	BEARING	LENGTH
L1	S 20°-21'-54" W	165'-2.3'
L2	S 15°-18'-02" W	207'-10.2'
L3	S 71°-45'-54" E	48'-0.0'
L4	S 18°-07'-58" W	70'-0.0'
L5	N 71°-32'-54" W	70'-0.0'
L6	N 18°-07'-58" E	70'-0.0'
L7	S 71°-45'-54" E	22'-0.0'

CLIENT
NEXTEL
 NEXTEL COMMUNICATIONS
 OF THE MID-ATLANTIC, INC.
 7055 SAMUEL MORSE DRIVE
 SUITE 100
 COLUMBIA MD 21048
 410-953-7400

KM Consulting Engineers, Inc.
 Consulting Engineering and Project Management
 39 WEST GORP FERRY RD.
 SUITE 100 JERRY BUSH
 FERRY VA 22611
 PHONE: (404) 538-6000
 FAX: (404) 538-6008
 E-MAIL: kmengr@comcast.net
 WEB PAGE: KMVA/WWW.KMENG.COM

UNAUTHORIZED ALTERATION OR ADDITIONS TO A PLAN BEARING THE SEAL OF A LICENSED ENGINEER, LAND SURVEYOR, AND / OR ARCHITECT IS A VIOLATION OF STATE LAW. COPIES FROM THE ORIGINAL OF THIS DOCUMENT WITHOUT A FACSIMILE OF THE SIGNATURE AND AS ORIGINAL OF THE ENGINEER OR LICENSED SEAL OF THE PROFESSIONAL ENGINEER, LAND SURVEYOR, AND / OR ARCHITECT SHALL NOT BE CONSIDERED VALID COPIES.

COPYRIGHT 2004

MICHAEL L. BOHLINGER, PE
 VIRGINIA PROFESSIONAL ENGINEER
 LICENSE # 402031626, VA

PROJECT PARTICIPANTS

SITE ACQUISITION: SIGN OFF INT. DATE

RF ENGINEER: SIGN OFF INT. DATE

CONSTR. SURV.: SIGN OFF INT. DATE

ZONING SURV.: SIGN OFF INT. DATE

A & E: KM CONSULTING ENGR'S, INC.

REVISIONS

NO.	DATE	BY	DESCRIPTION
2	02/10/05	RBA	CLIENT CHANGES PER TOWNSHIP
1	11/19/04	PPA	FINAL CONSTRUCTION
0	08/18/04	RBA	CONST. REVIEW

PROJECT NAME:
 VA-2645-A
 CASTLEMAN'S FERRY
PROJECT ADDRESS:
 483 HARRY BYRD HIGHWAY
 BERRYVILLE, VA 22611

DRAWING TITLE:
 ENLARGED SITE PLAN

P.C. FILE	C.H.D. FILE	DRN. FILE	DATE
			18-JUN-2004

SITE ID: VA-2645-A DRAWING #: REV. #

PROJECT #: 040108 **C-2 1**

FILE NAME: I2_C-2 (040108).dwg



Personnel Committee Items

Berryville/Clarke County Government Center, 2nd Floor
101 Chalmers Court, Berryville, Virginia 22611

Tuesday, October 12, 2021, 9:30 am

<i>Item No.</i>	<i>Description</i>	<i>Page</i>
A.	Expiration of Term for appointments expiring through December 2021	100
	2021-10-12 Summary: The Personnel Committee recommends the following:	
	<ul style="list-style-type: none">– The appointment of Jerry Stollings as the Court Services Unit Supervisor representative on the Community Policy and Management Team, replacing Kista Opoku-Achampo, for a term expiring December 31, 2022.– The reappointment of Rives Bacon for a four-year term on the Handley Regional Library Board, the new term expiring November 30, 2025.– The appointment of Linda Botkin to the Northwestern Community Services Board for a three-year term beginning January 1, 2022, and ending December 31, 2024, replacing Celie Harris, who hits the term limit for this board on December 31, 2021.– The reappointment of Chris Boies to the Northwestern Regional Jail Authority, the new term ending December 31, 2022.	

Appointments by Expiration Through December 2021

Appt Date Exp Date Orig Appt Date:

August 2021

Fire & EMS Commission 1 Yr

Beatty	David	Blue Ridge VFRC Rep	7/21/2020	8/31/2021	12/17/2019
--------	-------	---------------------	-----------	-----------	------------

The Commission shall consist of eight (8) members including:
 -1 member of the Board of Supervisors; The Clarke County Sheri; 1 representative from each of the volunteer fire and EMS companies; 3 citizens-at-large representing consumers of fire and EMS services. The 3 volunteer fire and EMS company representatives shall serve one-year terms and shall be appointed by the Board of Supervisors with recommendation to be provided by the volunteer companies. The 3 citizens-at-large shall be appointed for 4 year terms. The Sheriff shall serve a term coterminous with the term of office.
 The Board of Supervisors shall appoint a representative annually at or shortly after its annual organizational meeting to serve a one-year term

September 2021

Clarke County Library Advisory Council 4 Yr

Curran	Christopher	Buckmarsh District	4/20/2021	9/20/2021	5/16/2006
--------	-------------	--------------------	-----------	-----------	-----------

Resigned 09/20/2021, Term Expires 04/15/2025

The Council shall consist of nine (9) regular members and one liaison from the BoS. The BoS shall appoint the liaison for a one (1) year term. Members may be recommended by the Council to the BoS, and shall be appointed for four (4) year terms by the BoS. Members can be reappointed for a maximum of three consecutive terms. If a member misses three consecutive meetings, the board reserves the right to vote to terminate membership

Community Policy and Management Team 3 Yr

Opoku-Achampo	Kista	Court Services Unit Supervisor	7/1/2020	9/28/2021	3/17/2020
---------------	-------	--------------------------------	----------	-----------	-----------

Replaced Mark Legrys Supervisor 07/2020, term expired 12/31/2022 Jerry Stolling filled

2.2-5205 shall include, at a minimum, at least one elected official or appointed official or his designee from the governing body of a locality that is a member of the team, & the local agency heads or their designees of the following community agencies: community services board established pursuant to § 37.2-501, juvenile court services unit, dept of health, dss, & the local school div. The team shall also include a rep of a private org or assoc of providers for children's or family services if such organizations or associations are located within the locality, & a parent representative. Parent representatives who are employed by a public or private program that receives funds pursuant to this chapter or agencies represented on a community policy and management team may serve as a parent representative provided that they do not, as a part of their employment, interact directly on a regular and daily basis with children or supervise employees who interact directly on a daily basis with children. Notwithstanding this provision, foster parents may serve as parent representatives. Those persons appointed to represent community agencies shall be authorized to make policy and funding decisions for their agencies. COI - Parent & Private - SOEI file at time of original appointment only

November 2021

Handley Regional Library Board 4 Yr

Bacon	Rives		11/17/2020	11/30/2021	11/17/2020
-------	-------	--	------------	------------	------------

filled unexpired term of Cindy Leah
 1 Clarke County Member; 2 Term Limit

December 2021

Barns of Rose Hill Board of Directors 3 Yr

Cook	Peter		4/20/2021	12/31/2021	4/20/2021
------	-------	--	-----------	------------	-----------

A Board Member is elected for a three-year term and may serve a maximum of two terms. One member of the Board will be named by the Town Council of Berryville and will serve as liaison to the Town. One member will be named by the Clarke County Board of Supervisors and will serve as liaison to the County. The two liaisons will be considered regular Board Members, with the same rights and responsibilities as other Board Members. A director may be elected for up to two consecutive three-year terms, after which a year must be spent off the Board before consideration for Board re-appointment. A director's term shall begin January 1.

			<i>Appt Date</i>	<i>Exp Date</i>	<i>Orig Appt Date:</i>
Community Policy and Management Team			3 Yr		
Greene	Colin	VDH Representative	12/18/2018	12/31/2021	12/19/2017
Complete unexpired term of April Jenkins					
<p>2.2-5205 shall include, at a minimum, at least one elected official or appointed official or his designee from the governing body of a locality that is a member of the team, & the local agency heads or their designees of the following community agencies: community services board established pursuant to § 37.2-501, juvenile court services unit, dept of health, dss, & the local school div. The team shall also include a rep of a private org or assoc of providers for children's or family services if such organizations or associations are located within the locality, & a parent representative. Parent representatives who are employed by a public or private program that receives funds pursuant to this chapter or agencies represented on a community policy and management team may serve as a parent representative provided that they do not, as a part of their employment, interact directly on a regular and daily basis with children or supervise employees who interact directly on a daily basis with children. Notwithstanding this provision, foster parents may serve as parent representatives. Those persons appointed to represent community agencies shall be authorized to make policy and funding decisions for their agencies. COI - Parent & Private - SOEI file at time of original appointment only</p>					
Acker	Denise	Northwestern Community Services	12/18/2018	12/31/2021	6/12/2017
<p>2.2-5205 shall include, at a minimum, at least one elected official or appointed official or his designee from the governing body of a locality that is a member of the team, & the local agency heads or their designees of the following community agencies: community services board established pursuant to § 37.2-501, juvenile court services unit, dept of health, dss, & the local school div. The team shall also include a rep of a private org or assoc of providers for children's or family services if such organizations or associations are located within the locality, & a parent representative. Parent representatives who are employed by a public or private program that receives funds pursuant to this chapter or agencies represented on a community policy and management team may serve as a parent representative provided that they do not, as a part of their employment, interact directly on a regular and daily basis with children or supervise employees who interact directly on a daily basis with children. Notwithstanding this provision, foster parents may serve as parent representatives. Those persons appointed to represent community agencies shall be authorized to make policy and funding decisions for their agencies. COI - Parent & Private - SOEI file at time of original appointment only</p>					
Shirley	Leea	Alternate- VDH Representative	3/17/2020	12/31/2021	3/17/2020
Alternates est. 03-17-2020					
<p>2.2-5205 shall include, at a minimum, at least one elected official or appointed official or his designee from the governing body of a locality that is a member of the team, & the local agency heads or their designees of the following community agencies: community services board established pursuant to § 37.2-501, juvenile court services unit, dept of health, dss, & the local school div. The team shall also include a rep of a private org or assoc of providers for children's or family services if such organizations or associations are located within the locality, & a parent representative. Parent representatives who are employed by a public or private program that receives funds pursuant to this chapter or agencies represented on a community policy and management team may serve as a parent representative provided that they do not, as a part of their employment, interact directly on a regular and daily basis with children or supervise employees who interact directly on a daily basis with children. Notwithstanding this provision, foster parents may serve as parent representatives. Those persons appointed to represent community agencies shall be authorized to make policy and funding decisions for their agencies. COI - Parent & Private - SOEI file at time of original appointment only</p>					
Conservation Easement Authority					
Thomas	Walker	Buckmarsh District	12/18/2018	12/31/2021	12/21/2010
Term begins 1/1/2013					
<p>Board of Directors 7 members, appointed by the BOS, to be comprised of 1 member from the BOS, 1 member from the PC and 5 Clarke County citizen members. At the first meeting of the BOS each calendar year, beginning the Board shall appoint 1 member from the membership of the BOS for a term of 1 year beginning Jan 1; 1 member from the Planning Commission for a 1 year term beginning May 1; and a member or members to fill expiring citizen member terms, for a term of three (3) years beginning Jan 1.</p>					
Engel	Peter	White Post District	12/18/2018	12/31/2021	12/15/2009
<p>Board of Directors 7 members, appointed by the BOS, to be comprised of 1 member from the BOS, 1 member from the PC and 5 Clarke County citizen members. At the first meeting of the BOS each calendar year, beginning the Board shall appoint 1 member from the membership of the BOS for a term of 1 year beginning Jan 1; 1 member from the Planning Commission for a 1 year term beginning May 1; and a member or members to fill expiring citizen member terms, for a term of three (3) years beginning Jan 1.</p>					

			<i>Appt Date</i>	<i>Exp Date</i>	<i>Orig Appt Date:</i>
Economic Development Advisory Committee			4 Yr		
Dodson	Reid	Russell District	6/15/2021	12/31/2021	6/15/2021
<p>Members of the committee should include one or more people from all key government and business groups such as planning commission, board of supervisors, school board, industrial development authority, town of Berryville, chamber of commerce, and key business sectors such as agriculture, banking, realty, light industry, retail and tourism. Membership not limited. 4 year term.</p>					
Kraybill	Christina	Berryville District, Business Owner	12/19/2017	12/31/2021	11/18/2014
<p>2018-2019 Vice Chair</p> <p>Members of the committee should include one or more people from all key government and business groups such as planning commission, board of supervisors, school board, industrial development authority, town of Berryville, chamber of commerce, and key business sectors such as agriculture, banking, realty, light industry, retail and tourism. Membership not limited. 4 year term.</p>					
Northwestern Community Services Board			3 Yr		
Harris	Celie	Millwood District	2/19/2019	12/31/2021	12/21/2010
<p>Fills unexpired term of Kathleen Ruffo</p> <p>2 Clarke County Members; 3 Term Limit [AKA Chapter 10 Board; 37.2-501(A)]</p>					
Northwestern Regional Jail Authority			1 Yr		
Boies	Chris	BoS - Appointed Member	11/17/2020	12/31/2021	12/17/2019
<p>3 Clarke County Members; Sheriff - required appointment - concurrent with term of office; May appoint alternates</p>					
Parks & Recreation Advisory Board			4 Yr		
Smith	Tracy	Millwood District	12/19/2017	12/31/2021	1/17/2012
<p>There shall be nine (9) voting members on the Advisory Board. Six (6) members shall be appointed by the Board of Supervisors to represent the five (5) voting districts and one (1) at large. The Superintendent of Schools or the Superintendent's designee shall serve on the Advisory Board. The Town Councils for Berryville and Boyce shall each appoint a representative to serve on the Advisory Board. The Board of Supervisors shall also designate one (1) member of the Board of Supervisors to serve as a non-voting liaison to the Advisory Board. All terms, except the student representatives, shall be staggered and the initial terms shall be established by random lot. All terms subsequent to the initial terms shall be (4) years.</p>					
Sheetz	Daniel A.	Berryville District	12/19/2017	12/31/2021	3/18/2003
<p>Fills unexpired term of Leah Robinson</p> <p>There shall be nine (9) voting members on the Advisory Board. Six (6) members shall be appointed by the Board of Supervisors to represent the five (5) voting districts and one (1) at large. The Superintendent of Schools or the Superintendent's designee shall serve on the Advisory Board. The Town Councils for Berryville and Boyce shall each appoint a representative to serve on the Advisory Board. The Board of Supervisors shall also designate one (1) member of the Board of Supervisors to serve as a non-voting liaison to the Advisory Board. All terms, except the student representatives, shall be staggered and the initial terms shall be established by random lot. All terms subsequent to the initial terms shall be (4) years.</p>					

Clarke County Public Body Listing

			<i>Appt Date</i>	<i>Exp Date</i>
<i>Agricultural & Forestal District Advisory Committee</i>				6 Yr
Childs	Corey	Landowner	7/20/2021	7/15/2027
Conrad	Sam	Landowner/Producer	8/17/2021	7/15/2027
Day	Emily	Landowner/Producer	7/20/2021	7/15/2027
Dorsey	Tupper	Landowner/Producer	8/17/2021	7/15/2027
Hartsook	Shawna	Landowner/Producer	8/17/2021	7/15/2027
McKay	Beverly B.	BoS - Appointed Member	8/17/2021	7/15/2027
Peake	Donna	Commissioner of the Revenue	8/17/2021	7/15/2027
Shenk	Philip	Landowner/Producer	8/17/2021	7/15/2027
Simmons	Tait	Landowner	8/17/2021	7/15/2027
<i>Barns of Rose Hill Board of Directors</i>				3 Yr
Cook	Peter		4/20/2021	12/31/2021
<i>BCCGC Joint Building Committee</i>				Open-End
Arnold, Jr.	Harry Lee	Berryville Town Council Representative	1/11/2018	
Boies	Chris	County Administrator	12/2/2019	
Dalton	Keith	Berryville Town Manager		
McKay	Beverly B.	BoS - Appointed Member	1/19/2021	12/31/2021
Taylor	Brianna R.	Clerk	12/2/2019	
<i>Berryville Area Development Authority</i>				3 Yr
Ohrstrom, II	George	Russell District	4/16/2019	3/31/2022
Smart	Kathy	White Post District	4/21/2020	3/31/2023
Weiss	David S.	Buckmarsh/Blue Ridge District	4/16/2019	3/31/2022
<i>Berryville/Clarke County Joint Committee for Economic Development and Tourism</i>				Ongoing
Arnold, Jr.	Harry Lee	BTC - Appointed Member		
Boies	Chris	County Administrator	12/2/2019	
Dalton	Keith	Town Manager		
Dunkle	Christy	Staff Representative - Town - Alternate		
Hart	Felicia	Director of Economic Development	3/23/2020	
Kemp	Tiffany	Clerk		
Lawrence	Doug	BoS - Appointed Member	1/19/2021	12/31/2021
Rodriguez	Kara	BTC - Appointed Member		
Weiss	David S.	BoS - Appointed Member	1/19/2021	12/31/2021
<i>Board of Septic & Well Appeals</i>				1 Yr
Bass	Matthew	BoS - Appointed Member	1/19/2021	12/31/2021
Blatz	Joseph	White Post District; Citizen Member	2/18/2020	2/15/2024

Tuesday, October 5, 2021

Page 1 of 8

			<i>Appt Date</i>	<i>Exp Date</i>
Buckley	Randy	White Post District; Planning Commission Vice-Chair	1/8/2021	12/31/2021
McKay	Beverly B.	BoS - Alternate	1/19/2021	12/31/2021
Ohrstrom, II	George	Russell District; Planning Commission Chair	1/8/2021	12/31/2021
Teetor	Alison	Staff Representative		

Board of Social Services

4 Yr

Byrd	Barbara J.	Russell District	1/1/2020	12/31/2023
Dabinett	Laura	Russell District	4/20/2021	7/15/2022
Dodson	Gerald	Berryville District	6/16/2020	7/15/2024
Lawrence	Doug	BoS - Appointed Member	1/19/2021	12/31/2021
Legard	Margaret	Berryville District	1/1/2019	12/31/2023
Parker	Jennifer	Staff Representative		
Smith	James	Berryville District	6/15/2021	7/15/2025
York	Robert	White Post District	9/15/2020	7/15/2022

Board of Supervisors

Bass	Matthew	Berryville District	11/3/2020	12/31/2023
Boies	Chris	Clerk	12/2/2019	
Catlett	Terri T.	Millwood/Pinegrove Districts	1/1/2020	12/31/2023
Lawrence	Doug	Russell District	1/1/2020	12/31/2023
McKay	Beverly B.	White Post District, Vice Chair	1/1/2020	12/31/2023
Taylor	Brianna R.	Deputy Clerk	12/2/2019	
Weiss	David S.	Buckmarsh/Blue Ridge Districts; Chair	1/1/2020	12/31/2023

Board of Supervisors Finance Committee

1 Yr

Catlett	Terri T.	BoS - Appointed Member	1/19/2021	12/31/2021
McKay	Beverly B.	BoS - Alternate	1/19/2021	12/31/2021
Weiss	David S.	BoS - Appointed Member	1/19/2021	12/31/2021

Board of Supervisors Personnel Committee

1 Yr

Catlett	Terri T.	BOS - Alternate	1/19/2021	12/31/2021
McKay	Beverly B.	BoS - Appointed Member	1/19/2021	12/31/2021
Weiss	David S.	BoS - Appointed Member	1/19/2021	12/31/2021

Board of Zoning Appeals

5 Yr

Borel	Alain F.	White Post District	4/1/2019	2/15/2024
Brumback	Clay	White Post District	12/15/2020	2/12/2023
Caldwell	Anne	Millwood District	2/26/2020	2/15/2025
Camp	Jeremy	Staff Representative		
Means	Howard	Millwood District	1/19/2021	2/15/2026
Shenk	Philip	Alternate	6/15/2021	2/15/2024
Volk	Laurie	White Post District	7/15/2019	2/15/2024

Tuesday, October 5, 2021

Page 2 of 8

			<i>Appt Date</i>	<i>Exp Date</i>
<i>Broadband Implementation Committee</i>				
Dunning	Buster	White Post District	6/8/2020	
Houck	William	Citizen Representative	7/1/2020	6/30/2022
Kruhm	Doug	Buckmarsh / Battletown District	9/18/2018	
Lawrence	Doug	Russell District	1/19/2021	12/31/2021
McKay	Beverly B.	White Post District	1/19/2021	12/31/2021
<i>Building and Grounds</i>				1 Yr
McKay	Beverly B.	BoS - Appointed Member	1/19/2021	12/31/2021
Weiss	David S.	BoS - Alternate	1/19/2021	12/31/2021
<i>Career and Technical Education Advisory Committee</i>				1 Yr
Catlett	Terri T.	BoS - Appointed Member	1/19/2021	12/31/2021
<i>Clarke County Historic Preservation Commission</i>				4 Yr
Arnett	Betsy	Berryville District	4/21/2020	5/31/2024
Berger	Katherine	Buckmarsh District	5/21/2019	5/31/2023
Camp	Jeremy	Staff Representative		
Carter	Paige	White Post District	4/21/2020	5/31/2024
Catlett	Terri T.	BoS - Liaison	1/19/2021	12/31/2021
Kruhm	Doug	Planning Commission Representative	2/18/2020	12/31/2023
Stieg, Jr.	Robert	Millwood District	6/17/2014	5/31/2022
Thompson	Billy	White Post District	4/20/2021	5/31/2025
York	Robert	White Post District	4/20/2021	5/31/2025
<i>Clarke County Humane Foundation</i>				1 Yr
Catlett	Terri T.	BoS - Liaison	1/19/2021	12/31/2021
<i>Clarke County Library Advisory Council</i>				4 Yr
Al-Khalili	Adeela	Buckmarsh District	4/16/2019	4/15/2022
Bass	Matthew	BoS - Liaison	1/19/2021	12/31/2021
Bogert	Aubrey	White Post District	4/17/2018	4/15/2022
Brondstater	Bette	Berryville District	4/16/2019	4/15/2022
Daisley	Shelley	Russell District	4/21/2020	4/15/2024
Foster	Nancy	Russell District	4/21/2020	4/15/2024
Kalbian	Maral	Millwood District	4/16/2019	4/15/2022
Mitchell	Jessica	Berryville District	4/20/2021	4/15/2025
Payne	Lisa	Berryville District	4/20/2021	4/15/2025
<i>Clarke County Litter Committee</i>				
Bass	Matthew	BoS - Liaison	9/21/2021	12/31/2021
Bauhan	Tom	White Post District	9/21/2021	9/30/2024
Harrison	Ashley	Berryville District	9/21/2021	9/30/2024

Tuesday, October 5, 2021

Page 3 of 8

			<i>Appt Date</i>	<i>Exp Date</i>
Keim	John	Russell District	9/21/2021	9/30/2024
Martin	Mary	White Post District	9/21/2021	9/30/2024
Roque	Meg	Buckmarsh District	9/21/2021	9/30/2024
Teetor	Alison	Staff Representative		

Clarke County Planning Commission

1 Yr.

Bass	Matthew	BoS - Appointed Member	1/19/2021	12/31/2021
Buckley	Randy	White Post District	4/17/2018	4/30/2022
Caldwell	Anne	Millwood / Chapel District	3/21/2017	4/30/2025
Dunning	Buster	White Post / Greenway District	4/21/2020	4/30/2024
Glover	Robert	Millwood District	4/16/2019	4/30/2023
Hunt	Pearce	Russell District	5/19/2020	4/30/2025
Kreider	Scott	Buckmarsh / Battletown District	4/21/2020	4/30/2024
Kruhm	Doug	Buckmarsh / Battletown District	4/17/2018	4/30/2022
Lawrence	Doug	BoS - Alternate	1/19/2021	12/31/2021
Lee	Francis	Berryville District	4/17/2018	4/30/2022
Malone	Gwendolyn	Berryville District	4/21/2020	4/30/2024
Ohrstrom, II	George	Russell District	4/16/2019	4/30/2023
Stidham	Brandon	Staff Representative	4/30/2012	

Clarke County Sanitary Authority

4 Yr

Armbrust	Wayne	White Post District	11/17/2020	6/30/2024
Bauhan	Tom	White Post District	5/21/2019	1/5/2022
DeArment	Roderick	White Post District	12/15/2020	1/5/2025
Mackay-Smith, Jr.	Alexander	White Post District	11/17/2020	1/5/2025
McKay	Beverly B.	BoS - Liaison	1/19/2021	12/31/2021
Meredith	Mary	Staff Representative	1/2/2018	
Myer	Joseph	Town of Boyce	2/18/2020	2/15/2024

Community Policy and Management Team

3 Yr

Acker	Denise	Northwestern Community Services	12/18/2018	12/31/2021
Austin	Michael	Alternate- Department of Social Services	3/17/2020	12/31/2022
Catlett	Terri T.	BoS - Appointed Member	1/19/2021	12/31/2021
Greene	Colin	VDH Representative	12/18/2018	12/31/2021
Moore	Frank	CCPS Representative	10/15/2019	12/31/2022
Parker	Jennifer	Director Clarke County DSS	1/19/2021	12/31/2020
Samad	Abdus	Private Provider - Grafton School	12/17/2019	12/31/2022
Shirley	Leea	Alternate- VDH Representative	3/17/2020	12/31/2021
Willis	James	Parent Representative	9/21/2021	12/31/2023

Conservation Easement Authority

3 Yr

Bacon	Rives	White Post District	12/17/2019	12/31/2022
-------	-------	---------------------	------------	------------

Tuesday, October 5, 2021

Page 4 of 8

			<i>Appt Date</i>	<i>Exp Date</i>
Buckley	Randy	White Post District	12/17/2019	12/31/2022
Catlett	Terri T.	BoS - Appointed Member	1/19/2021	12/31/2021
Engel	Peter	White Post District	12/18/2018	12/31/2021
Jones	Michelle	Millwood / Pine Grove District	12/17/2019	12/31/2022
Ohrstrom, II	George	Russell District; Planning Commission Representative	4/16/2019	4/30/2022
Teetor	Alison	Staff Representative		
Thomas	Walker	Buckmarsh District	12/18/2018	12/31/2021
<i>Constitutional Officer</i>				<i>4 Yr</i>
Keeler	Sharon	Treasurer	1/1/2020	12/31/2023
Peake	Donna	Commissioner of the Revenue	1/1/2020	12/31/2023
Roper	Anthony	Sheriff	1/1/2020	12/31/2023
Wilkerson	April	Clerk of the Circuit Court	11/3/2020	12/31/2023
Williams	Anne	Commonwealth Attorney	1/1/2020	12/31/2023
<i>County Administrator</i>				<i>Open-End</i>
Boies	Chris	County Administrator	12/2/2019	
<i>Director of Economic Development</i>				
Hart	Felicia	Director of Economic Development	3/23/2020	
<i>Economic Development Advisory Committee</i>				<i>4 Yr</i>
Bates	Chris	Agriculture, Equine, Transportation	2/19/2019	12/31/2022
Dodson	Reid	Russell District	6/15/2021	12/31/2021
Dunkle	Christy	Town of Berryville Representative	2/18/2020	12/31/2023
Hart	Felicia	Director of Economic Development	3/23/2020	
Kemp	Tiffany	Clerk		
Kraybill	Christina	Berryville District, Business Owner	12/19/2017	12/31/2021
McKay	Beverly B.	BoS - Appointed Member	1/19/2021	12/31/2021
Milleson	John R.	Banking, Finance	1/15/2019	12/31/2022
Pritchard	Betsy	Hospitality Industry, agriculture	7/21/2020	8/31/2024
Sheaffer	Lee	Russell District, tourism	3/19/2019	12/31/2022
<i>Fire & EMS Commission</i>				<i>1 Yr</i>
Armacost, Jr.	Van	John H. Enders VFRC Rep	9/1/2021	8/31/2022
Beatty	David	Blue Ridge VFRC Rep	7/21/2020	8/31/2021
Buckley	Randy	Citizen-at-Large	10/15/2019	8/31/2023
Conrad	Bryan H.	Boyce VFRC Rep	9/1/2021	8/31/2022
Harrison	Diane	Citizen-at-large	8/17/2021	8/31/2025
Lawrence	Doug	BoS - Alternate	1/19/2021	12/31/2021
Lichty	Brian	Staff Representative	11/14/2016	
Loker	Randall	Citizen-at-large	7/21/2020	8/31/2024

			<i>Appt Date</i>	<i>Exp Date</i>
Roper	Anthony	Sheriff	1/1/2020	12/31/2023
Weiss	David S.	BoS - Representative	1/19/2021	12/31/2021
<i>Handley Regional Library Board</i>				4 Yr
Bacon	Rives		11/17/2020	11/30/2021
<i>Industrial Development Authority of the Clarke County, Virginia</i>				4 Yr
Cochran	Ben	Buckmarsh District	11/19/2019	10/30/2025
Ferrell	Brian	Buckmarsh District	10/15/2019	10/30/2023
Hart	Felicia	Director of Economic Development	3/23/2020	
Kemp	Tiffany	Clerk		
Koontz	English	Buckmarsh District	10/16/2018	10/30/2022
Pierce	Rodney	Buckmarsh District	9/15/2020	10/30/2024
Preston	Isreal	Berryville District	2/19/2019	10/30/2022
Waite	William	Millwood District	10/31/2017	10/30/2025
Weiss	David S.	BoS - Liaison	1/19/2021	12/31/2021
Wolfe	William	Millwood District	10/15/2019	10/30/2023
<i>Joint Administrative Services Board</i>				Open-End
Bennett	Brenda	Staff Representative	7/1/2020	
Bishop	Chuck	School Superintendent	7/1/2014	
Boies	Chris	County Administrator	12/2/2019	
Keeler	Sharon	Treasurer	3/12/2005	
McKay	Beverly B.	BoS - Alternate	1/19/2021	12/31/2021
Schutte	Charles	School Board Representative	1/8/2012	
Taylor	Brianna R.	Recording Clerk		
Weiss	David S.	BoS - Appointed Member	1/19/2021	12/31/2021
<i>Josephine School Community Museum Board</i>				1 Yr
Bass	Matthew	BoS - Liaison	1/19/2021	12/31/2021
<i>Legislative Liaison and High Growth Coalition</i>				1 Yr
Bass	Matthew	BoS - Liaison	1/19/2021	12/31/2021
<i>Lord Fairfax Community College Board</i>				4 Yr
Tabatabai	Maryam	Russell District	7/21/2020	6/30/2024
<i>Lord Fairfax Emergency Medical Services Council</i>				1 Yr
Conrad	Bryan H.	Volunteer Representative; White Post District	6/16/2020	3/15/2022
Trent	Carolyn	Medical Professional	6/16/2020	3/15/2022
Wilson	Wade	Career Representative	6/16/2020	3/15/2022
<i>Lord Fairfax Soil & Water Conservation District</i>				Elected

Tuesday, October 5, 2021

Page 6 of 8

			<i>Appt Date</i>	<i>Exp Date</i>
Mackay-Smith	Justin	Soil and Water Conservation Director Lord Fairfax District	1/1/2019	12/31/2023
Webb	Wayne	Soil and Water Conservation Director Lord Fairfax District	1/1/2019	12/31/2023
<i>Northern Shenandoah Valley Regional Commission</i>				1 Yr
Bass	Matthew	BoS - Alternate	1/19/2021	12/31/2021
McKay	Beverly B.	BoS - Appointed Member	1/19/2021	12/31/2021
Stidham	Brandon	Citizen Representative [Planning Director]	1/15/2019	1/31/2022
<i>Northwest Regional Adult Drug Treatment Court Advisory Committee</i>				1 Yr.
Bass	Matthew	BoS - Appointed Member	1/19/2021	12/31/2021
<i>Northwestern Community Services Board</i>				3 Yr
Goshen	Lisa	Millwood District	9/21/2021	12/31/2023
Harris	Celie	Millwood District	2/19/2019	12/31/2021
McKay	Beverly B.	BoS - Appointed Member	1/19/2021	12/31/2021
<i>Northwestern Regional Jail Authority</i>				1 Yr
Boies	Chris	BoS - Appointed Member	11/17/2020	12/31/2021
Lawrence	Doug	BoS - Liaison	1/19/2021	12/31/2023
Roper	Anthony	Sheriff	1/1/2020	12/31/2023
<i>Northwestern Regional Juvenile Detention Center Commission</i>				1 Yr
Bass	Matthew	BoS - Liaison	1/19/2021	12/31/2021
Roper	Anthony	Sheriff	9/21/2021	12/20/2024
<i>Old Dominion Alcohol Safety Action Policy Board & Division of Court Services</i>				3 Yr
Roper	Anthony	Sheriff	12/17/2019	12/31/2022
<i>Old Dominion Community Criminal Justice Board</i>				3 Yr
Roper	Anthony	Sheriff	12/17/2019	12/31/2022
<i>Our Health</i>				3 Yr
Shipe	Diane	Buckmarsh District	4/16/2019	3/15/2022
<i>Parks & Recreation Advisory Board</i>				4 Yr
Bacci	Stephen	Appointed by Town of Boyce	11/17/2020	12/31/2023
Catlett	Terri T.	BoS - Liaison	1/19/2021	12/31/2021
Huff	Ronnie	Town of Berryville Representative	2/18/2020	12/31/2023
Lichliter	Gary	Russell District	12/17/2019	12/31/2023
Merriman	Susan	White Post District	8/17/2021	12/31/2023
Rhodes	Emily	Buckmarsh District	12/17/2019	12/31/2023
Sheetz	Daniel A.	Berryville District	12/19/2017	12/31/2021
Smith	Tracy	Millwood District	12/19/2017	12/31/2021

Tuesday, October 5, 2021

Page 7 of 8

			<i>Appt Date</i>	<i>Exp Date</i>
Trenary	Randy	School Superintendent Designee	10/24/2013	
Voelkel	Eric	At Large	8/17/2021	12/31/2022
<i>Regional Airport Authority</i>				1 Yr
Boies	Chris	BoS - Alternate	1/21/2020	12/31/2020
McKay	Beverly B.	BoS - Alternate	1/19/2021	12/31/2021
Melanson	Leslie	Russell District	5/19/2020	6/30/2024
<i>Shenandoah Area Agency on Aging, Inc.</i>				4 Yr
Pritchard	Betsy		9/30/2018	9/30/2022
<i>Shenandoah Valley Chief Local Elected Officials Consortium</i>				
Seal	Cathy	Alternate	2/18/2020	12/31/2023
<i>Strategic Planning Committee</i>				1 Yr
Catlett	Terri T.	BoS - Appointed Member	1/19/2021	12/31/2021
<i>Towns and Villages: Berryville</i>				1 Yr
Bass	Matthew	BoS - Liaison - Alternate	1/19/2021	12/31/2021
McKay	Beverly B.	BoS - Liaison	1/21/2020	12/31/2020
<i>Towns and Villages: Boyce</i>				1 Yr
Catlett	Terri T.	BoS - Liaison	1/19/2021	12/31/2021
McKay	Beverly B.	BoS - Liaison	1/19/2021	12/31/2021
<i>Towns and Villages: Millwood</i>				1 Yr
Catlett	Terri T.	BoS - Liaison	1/19/2021	12/31/2021
<i>Towns and Villages: Pine Grove</i>				1 Yr
Catlett	Terri T.	BoS - Liaison	1/19/2021	12/31/2021
Weiss	David S.	BoS - Liaison	1/19/2021	12/31/2021
<i>Towns and Villages: White Post</i>				1 Yr
McKay	Beverly B.	BoS - Liaison	1/19/2021	12/31/2021



Board of Supervisors Work Session Agenda
Berryville/Clarke County Government Center, 2nd Floor
101 Chalmers Court, Berryville, Virginia 22611

October 12, 2021, 10:00 AM, Meeting Room AB

Board Members Present: Matthew E. Bass, Doug M. Lawrence, Beverly B. McKay, David S. Weiss (participating by phone from his home).

Board Members Absent: Terri T. Catlett

Officers / Staff Present: Chris Boies, Cathy Kuehner, Dr. Chuck Bishop

Others Present: None

Press Present: None

<i>Item No.</i>	<i>Description</i>	<i>Page</i>
	2021-10-12 Summary: At 10:00 am, Vice-Chair McKay called the meeting to order.	
A.	School System Update-Dr. Chuck Bishop, Superintendent for Clarke County Public Schools, provided the following presentation to the Board. Following the presentation, the Board of Supervisors thanked Dr. Bishop and the School Board for their work and for the positive relationship between the two boards.	



Enrollment

- Current enrollment
 - FY22 Budget K-12 enrollment of 1713 plus 40 PK students
 - Current enrollment K-12 of 1813 plus 30 PK students
- 2020-2021 enrollment
 - 1722 students in K-12 plus 19 PK students

School Enrollment

	Budgeted	Actual	
Boyce	239	281	+30 PK
Cooley	421	432	
J-WMS	390	419	
CCHS	663	681	

2020-2021 School Year

- Elementary began 2 days per week hybrid. MS and HS began virtual
- MS and HS began 2 days per week in November
- Hybrid students transitioned to 4 days per week in April
- Nearly 500 students chose an all virtual program
- Significant mitigation strategies were in place for students and staff
- Covid related expenses offset by additional revenue

Achievement Results

- No CCPS schools are identified as needing improvement under Federal guidelines
- State accreditation was waived for all districts
- CCHS on-time graduation rate of 96%

CCHS English Reading

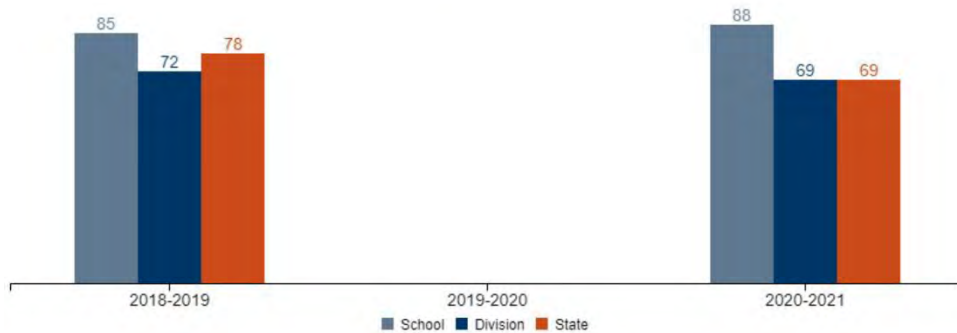

CCHS Mathematics

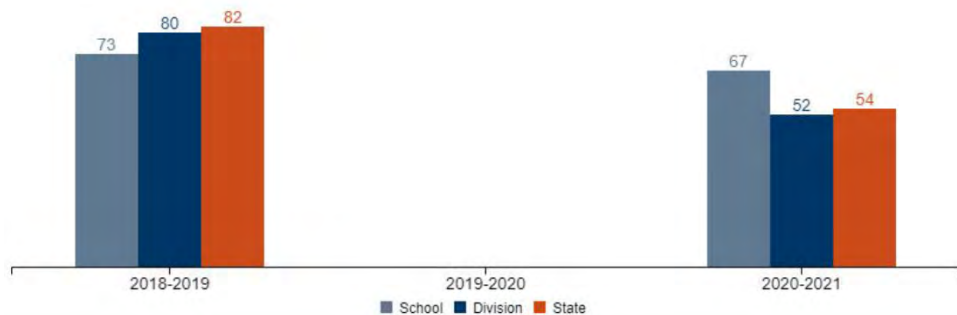

CCHS Science

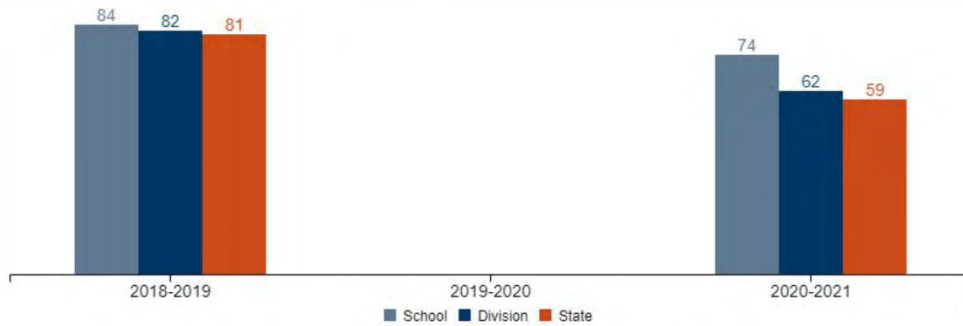

J-WMS English Reading

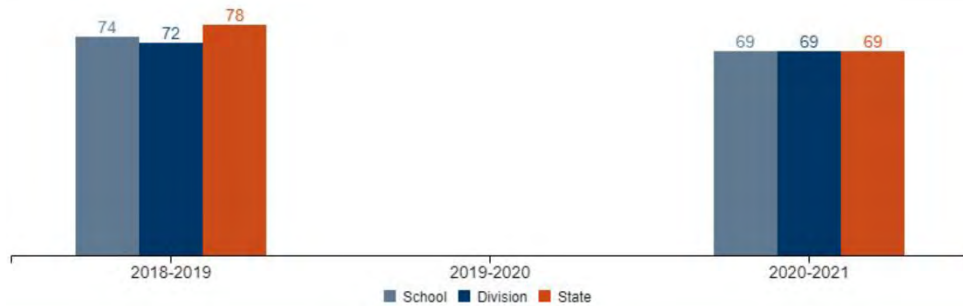

J-WMS Mathematics

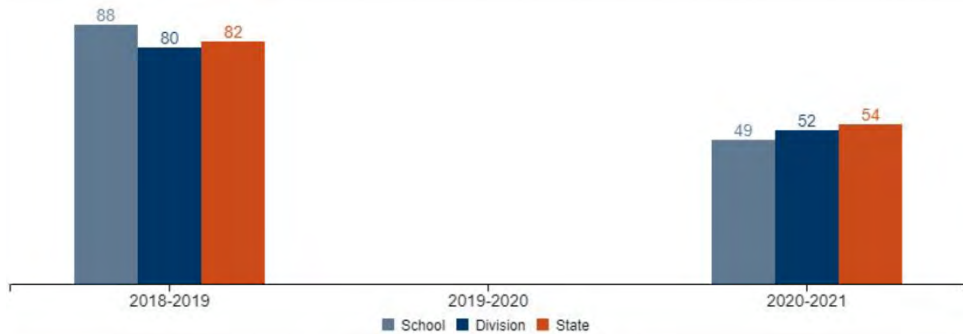

J-WMS Science

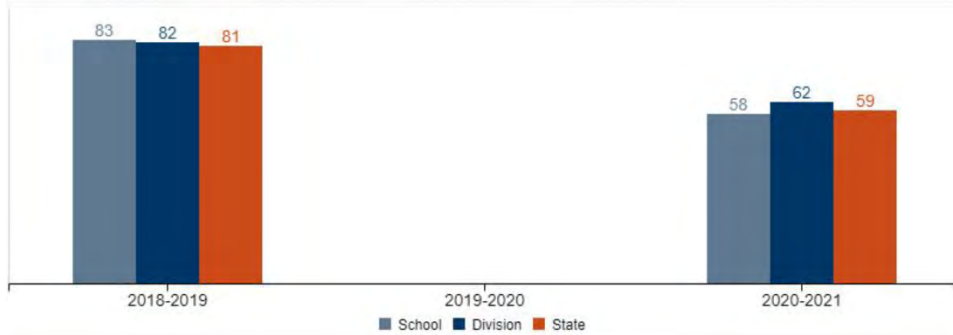

D.G. Cooley English Reading

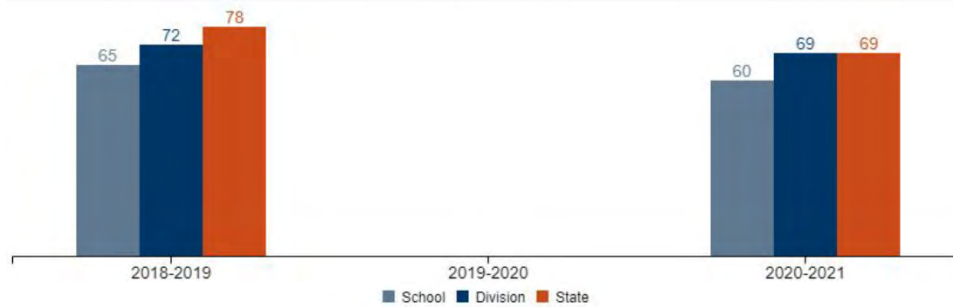

D.G. Cooley Mathematics

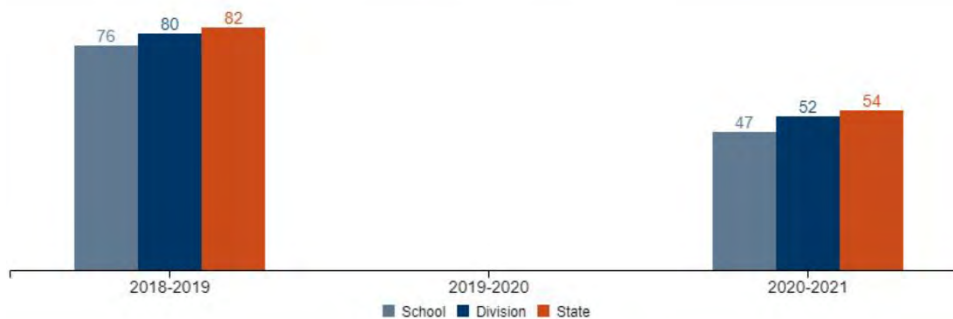

D.G. Cooley Science

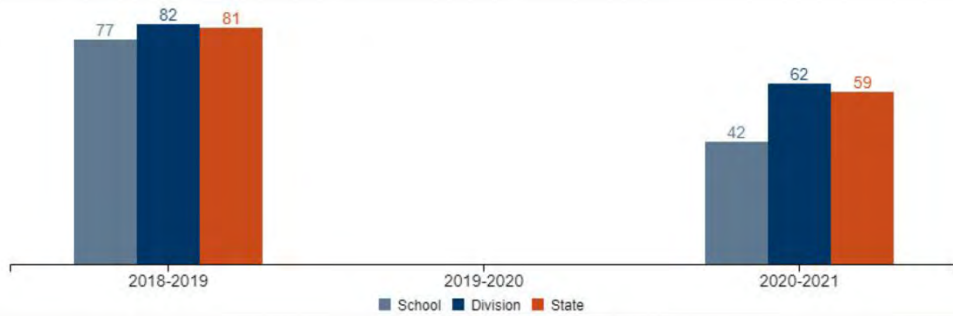

Boyce English Reading

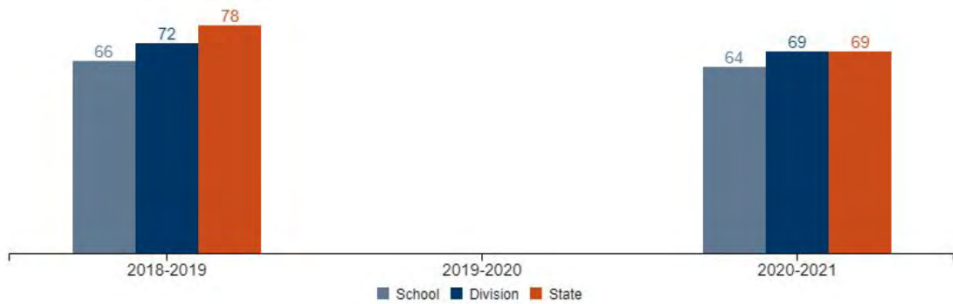

Boyce Mathematics

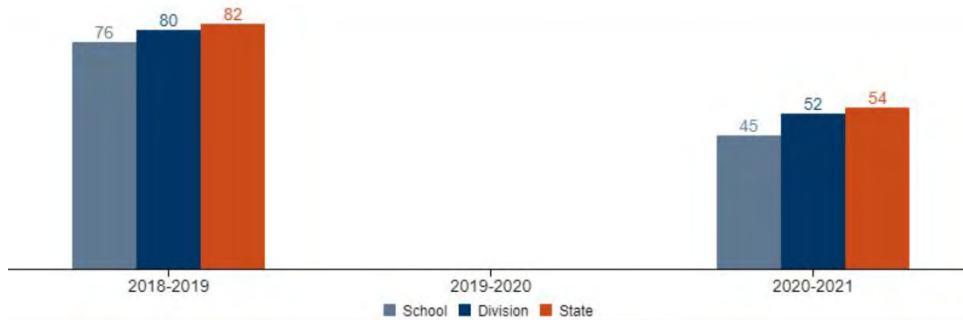

Boyce Science

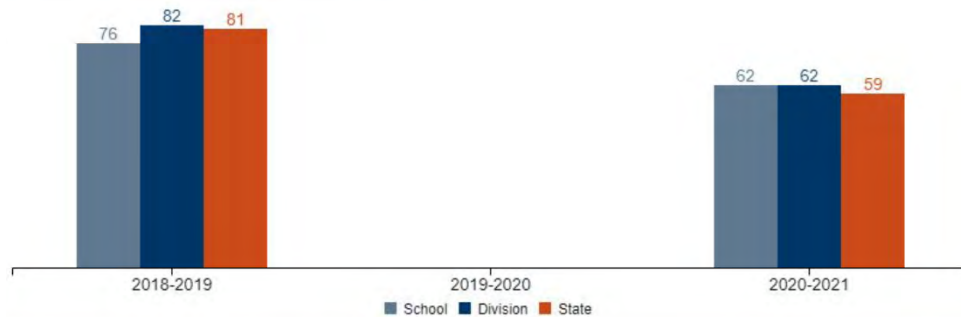

Virtual and In-Person

- This data is not available on the VDOE website.
- Generally, students who received in person instruction fared better on standardized assessments.
- The gap becomes more pronounced as the grade level decreases.
- Mathematics had the greatest disparity.

Virtual and In-Person

- All Standards of Learning assessments were administered on-site in schools.
- Very few families made the decision to refuse testing.

Number of Tests Taken by Learning Mode

	Tests Taken by Virtual Learners	Tests Taken by In-Person Learners
CCHS	194	498
J-WMS	327	812
D.G. Cooley	176	417
Boyce	79	233

CCHS English Reading

Virtual Pass Rate

90%

In-Person Pass Rate

86%

CCHS Mathematics

Virtual Pass Rate

57%

In-Person Pass Rate

70%

CCHS Science

Virtual Pass Rate

73%

In-Person Pass Rate

72%

J-WMS English Reading

Virtual Pass Rate

65%

In-Person Pass Rate

65%

J-WMS Mathematics

Virtual Pass Rate

37%

In-Person Pass Rate

50%

J-WMS Science

Virtual Pass Rate

54%

In-Person Pass Rate

56%

DG Cooley English Reading

Virtual Pass Rate

56%

In-Person Pass Rate

57%

DG Cooley Mathematics

Virtual Pass Rate

39%

In-Person Pass Rate

47%

DG Cooley Science

Virtual Pass Rate

31%

In-Person Pass Rate

43%

Boyce English Reading

Virtual Pass Rate

57%

In-Person Pass Rate

65%

Boyce Mathematics

Virtual Pass Rate

25%

In-Person Pass Rate

49%

Boyce Science

Virtual Pass Rate

46%

In-Person Pass Rate

71%

2021-2022 School Year

- 5 days per week of in-person learning
- 1813 students in K-12 plus 30 PK students
- No virtual offering for students
- By order of the Health Commissioner, all students, staff and visitors must wear a mask
- Lack of substitutes a concern
- ESSER III funds to provide math and reading interventions in each building. After school and summer school programming

Capital Projects Fund

- As of 9/10/21, \$259,412 remains in FY22 capital account.
- FY21 capital carryover request of \$669,430 approved by the school board on 9/20/21
- FY21 operating carryover to be discussed by the school board on 10/25/21.

The meeting was adjourned at 11:02 am.



Finance Committee Items

Berryville-Clarke County Government Center, 2nd Floor
101 Chalmers Court, Berryville, Virginia 22611

Tuesday, October 12, 2021, immediately following work session

Item No.	Description	Page
A.	<u>Independent Accountant's Report on Virginia Retirement System:</u> This item was added at the meeting. The attached letter from Robinson, Farmer, Cox Associates was presented to the Finance Committee, which shows the census data Clarke County reported to the Virginia Retirement System was "complete and accurate". This letter was presented to the Committee for informational purposes only; no action was taken.	123
B.	<u>Clarke County Department of Social Services Transfer:</u> (see attached)- Per the attached memo, The Clarke County Department of Social Services is requesting a transfer of \$19,000 from their FY22 personnel salaries line to their FY22 professional services line. This request will allow the CCDSS to acquire services and process a payment to Snowflake Consulting Services for the Strategic Planning process for the agency. The Finance Committee should consider approval of this request. 2021-10-12 Summary: The Finance Committee recommends approval of transferring \$19,000 from the Social Services FY 22 personnel salaries line item to their FY 22 professional services line item.	125
C.	<u>FY21 to FY22 School Capital Projects Carryforward:</u> (see attached)- Per the attached spreadsheet and memo, the proposed FY21 School Division Capital Carryforward amount is \$669,431. The Finance Committee should consider approval of the requested carryforward. 2021-10-12 Summary: The Finance Committee recommends approval of the Schools Capital Project Carryforward as requested.	126
D.	<u>FY21 to FY22 Government Capital Projects Carryforward:</u> (see attached) –Per the attached spreadsheet and memo, the proposed FY21 Government Capital Carryforward amount is \$849,740. The Finance Committee should consider approval of the requested carryforward. 2021-10-12 Summary: The Finance Committee recommends approval of the Government Capital Projects Carryforward as requested.	128
E.	<u>Discussion of 2022-27 Five Year Capital Improvement Plan:</u> See attached memo and spreadsheet.	131

Item No.	Description	Page
	2021-10-12 Summary: Information Only.	
F.	<u>Review FY23 Budget Calendar:</u> See attached calendar. The Finance Committee should consider approval of the proposed FY23 Budget Calendar.	133
	2021-10-12 Summary: The Finance Committee recommends approval of the FY 23 Budget Calendar as presented.	
G.	<u>Bills and Claims:</u> (see attached) The Finance Committee should consider approval.	134
	2021-10-12 Summary: Following review, the Finance Committee recommends approval of the September Invoice History Report.	
H.	<u>Standing Reports:</u>	
	– Year to Date Budget Report	145
	– Reconciliation of Appropriations	157
	– Capital Projects Report	158



Independent Accountants' Report

**Auditor of Public Accounts
P.O. Box 1295
Richmond, VA 23218**

We have examined management of the County of Clarke, Virginia's assertion that the census data reported to the Virginia Retirement System by the County of Clarke, Virginia during the year ended June 30, 2021, were complete and accurate based on the criteria set forth by the Virginia Retirement System and the Board of Trustees' plan provisions as mandated in § 51.1-136 of the Code of Virginia. County of Clarke, Virginia's management is responsible for the assertion. Our responsibility is to express an opinion on the assertion based on our examination.

Our examination was conducted in accordance with attestation standards established by the American Institute of Certified Public Accountants. Those standards require that we plan and perform the examination to obtain reasonable assurance about whether management's assertion is fairly stated, in all material respects. An examination involves performing procedures to obtain evidence about management's assertion. The nature, timing, and extent of the procedures selected depend on our judgment, including an assessment of the risks of material misstatement of management's assertion, whether due to fraud or error. We believe that the evidence we obtained is sufficient and appropriate to provide a reasonable basis for our opinion.

In our opinion, management's assertion that the census data reported to the Virginia Retirement System by the County of Clarke, Virginia during the year ended June 30, 2021, were complete and accurate based on the criteria set forth by the Virginia Retirement System and the Board of Trustees' plan provisions as mandated in § 51.1-136 of the Code of Virginia, is fairly stated, in all material respects.

This report is intended solely for the information and use of County of Clarke, Virginia and the Auditor of Public Accounts of the Commonwealth of Virginia and is not intended to be and should not be used by anyone other than these specified parties.

Robinson, Farmer, Cox Associates
(Robinson, Farmer, Cox Associates
September 30, 2021

cc: Board of Supervisors
School Board

Appendix A

We identified two control environments during this review, one for which County of Clarke, Virginia was responsible, and one for which the County of Clarke, Virginia’s School Board was responsible.

The following table reflects the population size and sample size for each procedure performed over the control environment for which County of Clarke, Virginia was responsible:

Required Audit Procedure	Population Size	Sample Size*	Risks and Other Considerations Used to Determine Sample Size
Review of Census Data Elements	80	8	10% deemed appropriate due to small population. Prior history and experience of staff, staff knowledge of VRS requirements, etc. was factored into determining sample size.
Review of Eligibility of Newly Enrolled Members Reported to the VRS	32	3	Small population and no errors noted in prior year.
Review of Monthly <i>myVRS</i> Navigator Contribution Confirmation Reconciliations	12	3	Very small population and no errors noted in prior year.
Review of <i>myVRS</i> Navigator System Access	6	6	Tested full population.

The following table reflects the population size and sample size for each procedure performed over the control environment for which the County of Clarke, Virginia’s School Board was responsible:

Required Audit Procedure	Population Size	Sample Size*	Risks and Other Considerations Used to Determine Sample Size
Review of Census Data Elements	190	25	Low assurance needed, 0 exceptions expected. Prior history, staff knowledge of VRS requirements, etc. was factored into determining sample size.
Review of Eligibility of Newly Enrolled Members Reported to the VRS	28	3	Small population and no errors noted in prior year.
Review of Monthly <i>myVRS</i> Navigator Contribution Confirmation Reconciliations	24	6	Very small population and no errors noted in prior year.
Review of <i>myVRS</i> Navigator System Access	6	6	Tested full population.

* Sample sizes are based on a 5% tolerable rate and approximately a 75% confidence level for populations over 250. Sample sizes for populations under 250 are based on a percentage of the population which is not less than 10%.



**Clarke County
DEPARTMENT OF SOCIAL SERVICES**

311 E. Main St.
Berryville, VA 22611
540-955-3700
Fax: 540-955-3958

October 1, 2021

TO: Brenda Bennet-Joint Administrative Services Finance Director

From: Jennifer Parker-Clarke County Dept. of Social Services Director

RE: Transfer of Funds

Clarke County Social Services is requesting a transfer of funds from salaries to professional services for the payment of services to Snowflake Consulting Services for the Strategic Planning process for the agency. We are requesting \$19,000 to be transferred from salaries line 1100 to professional services 3101. The contract is on file with Clarke County Purchasing Services as the Request for Proposals process has been completed.

If you should need anything additional, please contact me at extension 5192 or at Jennifer.l.parker@dss.virginia.gov.

Sincerely,

Jennifer Parker

Jennifer Parker

Jennifer Parker, M.P.A.
Director, Clarke County Dept. of Social Services

Clarke County Public Schools

317 West Main Street
Berryville, Virginia 22611
Phone: 540-955-6100
Fax: 540-955-6109
www.clarke.k12.va.us

Dr. Chuck Bishop
Superintendent

Rick Catlett
Assistant Superintendent

Dr. Cathy Seal
Director of Curriculum and Instruction

Randy Trenary
Director of Operations

"Encourage Inspire Empower"

September 24, 2021

To: Chris Boies
County Administrator

Brenda Bennett
Director, Joint Administrative Services

From: Dr. Chuck Bishop 
Division Superintendent

Re: FY21 Capital Account Fund Balance

At the September 20, 2021 meeting of the Clarke County School Board, members unanimously approved a motion to request that the existing FY21 Capital account fund balance be re-appropriated by the Clarke County Board of Supervisors for expenses to be incurred during FY22. Based on feedback from the Joint Administrative Services Office, the FY21 Capital fund balance is \$669,430.29. It is important to note that \$198,567 of the balance is part of the VPSA Technology Bond program and has specific spending requirements.

As in past years, division-level staff will prioritize keeping building systems in proper operating condition. It is anticipated that the remaining rooftop units at Cooley Lower campus will be replaced this year at an estimated cost of \$400,000.

Please find attached a spreadsheet detailing the funds remaining in the FY21 Capital account. As always, I appreciate your support and am willing to answer any questions.

PROPOSED FY21 CLARKE COUNTY SCHOOLS CAPITAL CARRYFORWARD

FUNCTION	ACCOUNT DESCRIPTION	FY21 ORIG	FY21 TRANFRS/	FY21 REVISED	FY21 YTD	Proposed	Proposed FY21	NOTES
		APPROP	ADJSMTS	BUDGET	EXP	EOY	CARRY	
						<i>Adjustments</i>	FORWARD	
61110	School Furniture Replacement	50,000	-12,375	37,625	29,693		7,932	Replace outdated/worn furniture at schools. Standardize classroom furnishings
61130	Uniform Repl & Band Instruments	0	20,000	20,000	8,066		11,934	Repair and replace instruments
61140	Athletics Equipment & Uniforms	8,000	26,825	34,825	34,825		0	
63500	School Bus Purchases	85,000	0	85,000	82,147	-2,853	0	Transfer funds to JWMS school repairs for gym sound baffles
65100	School Food Services	0	11,755	11,755	5,150		6,605	Repair food service equipment as needed
66223	Fencing		9,606	9,606	0		9,606	Replace wood fencing @ east side of CCHS property; around cooling tower and dumpster at JWMS; around transportation department
66233	School Signage		2,414	2,414	1,358		1,056	Replace signs as needed throughout the division
66250	Fields and Playgrounds		15,000	15,000			15,000	Match for Boyce ES playground (PTO to raise funds)
66253	Asphalt/Sidewalk/Track/Courts	20,000	145,000	165,000	164,809		191	\$10,000 appropriation in FY22 - refinish 3 gym floors; repave Cooley loading dock area
66612	Painting		25,000	25,000	6,670		18,330	Repaint JWMS hallways, gym and cafeteria
66616	Heating, Ventilation & A/C	46,000	158,342	204,342	114,247		90,095	Replace 4 rooftop units at Cooley using capital and grant money, and repair/replace equipment as needed
66636	Roof Replacements	100,000	35,000	135,000	126,629		8,371	Replace 480sqft section of EPDM roof at BES
66637	School Security System Grant		82,591	82,591	60,262		22,329	Security grant funds will be exhausted to replace cameras before using local funds
66644	Flooring	20,000	-13,475	6,525	6,525		0	
66645	Security Improvements	50,000	26,085	76,085	61,912		14,173	Rewire and reprogram entrance doors at CCHS; repair and/or replace surveillance cameras
66646	Boyce School Repairs	0	25,483	25,483	0		25,483	Replace front door and install handicapped accessible ramp
66648	Johnson Wms Middle Sch R	0	5,450	5,450	1,450	2,853	6,853	Sound baffles in the gymnasium
68100	Technology Classroom Ins	43,000	71,890	114,890	90,340		24,550	Purchase peripheral devices and cables for classroom instruction- ear buds, mice, HDMI cables, etc
68200	Technology Inst Support	0	250,000	250,000	45,031		204,969	Purchase student devices for grade K-2, teacher devices and classroom display panels.
68300	Technology Administratio	30,000	-30,000	0	0		0	
68700	Tech Fd Svc & Other Non-	0	13,298	13,298	9,913		3,385	Replace hardware used in food service lines as needed
	Sub-Total	452,000	867,889	1,319,889	849,026	0	470,863	
68100-115	Tech Classroom Instr (VPSA-tech. bond)	65,000	314,470	379,470	180,902		198,568	Purchase grade 3-12 student devices and refresh main network infrastructure
	Sub-Total	65,000	314,470	379,470	180,902		198,568	
	TOTALS	517,000	1,182,359	1,699,359	1,029,928	0	669,431	
Revenue								
68100-115		-154,000	-220,470	-374,470	-175,902		-198,568	
Transfer from General Fund				-1,324,889	-854,027		-470,863	
	TOTALS	-154,000		-1,699,359	-1,029,929		-669,431	

PROPOSED FY21 COUNTY CAPITAL CARRYFORWARD

FUNCTION	ACCOUNT DESCRIPTION	FY21 ORIG	FY21 TRANFRS/	FY21 REVISED	FY21 YTD	Proposed EOY Adjustments	Proposed FY21	NOTES
		APPROP	ADJSMTS	BUDGET	EXP		CARRY FORWARD	
94110	HVAC System Replacement	-	149,417	149,417	136,709		12,708	
94120	Roofing	-	42,731	42,731	38,308		4,423	
94130	Painting and Flooring	-	5,699	5,699			5,699	
94140	Landscaping	-	10,375	10,375	-		10,375	
94150	Asphalt, Sidewalk, Path	-	25,377	25,377	25,000		377	
94180	Courthouse Complex Repair	-	27,887	27,887	27,887		-	Project complete
94181	Courtroom Furniture	30,000	-	30,000	2,570		27,430	
94310	Sheriff's Equipment	29,000	20,558	49,558	27,533		22,026	
94320	Auto Replacement	25,000	5,990	30,990			30,990	
94329	AFG-Radio Replacements	587,300	-	587,300	-	(587,300)	-	AFG Grant not received
94331	Sheriff's Vehicles	171,000	27,490	198,490	186,063		12,427	
94509	Morgan's Mill Appalachia	-	11,730	11,730	11,730		-	Project complete
94601	Technology Improvements		21,329	21,329	5,000		16,329	
94603	Mobile Radio System	20,000	565,074	585,074	187,078		397,996	
94604	911 Phone System		206,772	206,772	24,293		182,479	
94702	Swimming Pool	-	44,446	44,446	11,302		33,144	
94703	Park Repairs	-	72,977	72,977	2,885		70,092	
94709	New Park Shelter	-	20,723	20,723	12,261		8,462	
94802	Reassessment	-	70,742	70,742	55,958		14,784	
	Total	862,300	1,329,317	2,191,617	754,577		849,740	
<u>Revenue</u>								
94508	Dept of Historic Resources -Josephine Roof		-530	-530	-630		-	Project complete
94509	Morgans Mill Appalachian Trail donations		-7,000	-7,000	-6,846		-	Project complete
94604	Wireless 911 Phone System Grant		-241,452	-241,452			-241,452	
94329	AFG-Radio Replacements	-557,935		-557,935		-557,935	-	AFG Grant not received
	Transfer from CARES Act fund		-20,219	-20,219	-20,219		-	
	Transfer from General Fund		-1,060,116	-1,364,481	-726,882	-29,365	-608,288	
		-557,935	-1,329,317	-2,191,617	-754,577	-587,300	-849,740	
	Revenue Total	-557,935	-1,329,317	-2,191,617	-754,577		-849,740	
	Expense Total	862,300	1,329,317	2,191,617	754,577		849,740	
	Grand Total		0	0	0		0	

Clarke County Board of Supervisors



Berryville Voting District
Matthew E. Bass
(540) 955-5175

Millwood Voting District
Terri T. Catlett
(540) 837-2328

Russell Voting District
Doug Lawrence
(540) 955-2144

Buckmarsh Voting District
David S. Weiss – Chair
(540) 955-2151

White Post Voting District
Bev B. McKay – Vice Chair
(540) 837-1331

County Administrator
Chris Boies
(540) 955-5175

To: Brenda Bennett

From: Chris Boies

Re: Capital Carryforward Request

Date: September 30, 2021

Per the attached spreadsheet your office has provided, please place the County Capital Carryforward request on the October agenda. I have provided a brief written narrative of our proposed uses for these funds:

HVAC-use the \$12,708 carryforward as contingency for the chiller replacement project at Circuit Courthouse

Roofing and Painting/Flooring-if BOS approves carryforward, staff would like permission to move these balances to Asphalt to pay for Josephine project.

Landscaping-if BOS approves carryforward, staff would like permission to move \$3,039 to Asphalt to pay for Josephine project.

Asphalt-new balance with transfers would be \$22,000 to pay for the installation of ten paved parking spaces (including two handicapped spaces) for Josephine Museum parking.

Courtroom Furniture-if approved by BOS, we would rebid this previously approved project for new seating in Circuit Courtroom.

Sheriff Equipment-leave for future use

Auto Replacement-if approved by BOS, would purchase new Maintenance vehicle which would have otherwise been requested in FY 23 budget.

Sheriff Vehicles-leave for future use

Technology Improvements-leave for future use, possibly cybersecurity efforts.

Mobile Radio System-project will be completed this fiscal year, \$75k in current budget is for Fire/Rescue repeaters.

911 Phone System-leave for future use

Swimming pool-leave for contingency

Park Repairs-leave for contingency

New Park Shelter-if carryforward is approved by the BOS, staff requests permission to transfer these funds to Asphalt for Josephine project.

AFG Radio Replacement-waiting to hear on grant award.

Clarke County Board of Supervisors



Berryville Voting District
Matthew E. Bass
(540) 955-5175

Millwood Voting District
Terri T. Catlett
(540) 837-2328

Russell Voting District
Doug Lawrence
(540) 955-2144

Buckmarsh Voting District
David S. Weiss – Chair
(540) 955-2151

White Post Voting District
Bev B. McKay – Vice Chair
(540) 837-1331

County Administrator
Chris Boies
(540) 955-5175

To: Brenda Bennett

From: Chris Boies

Re: 2022-27 Capital Improvement Plan

Date: September 30, 2021

Please place an item on the Finance agenda to discuss the process for the 2022-27 Capital Improvement Plan. Staff has started working on annual updates to the five-year capital improvement plan. Items that were on the 2021-26 plan (which is attached) that have been funded will be removed, new items requested by department heads and constitutional officers will be reviewed, and existing items will be re-reviewed for prioritization. This process will continue over the next couple weeks in preparation for providing the proposed plan to the Planning Commission at their November meeting. If the Planning Commission makes a recommendation in November, the item would be placed on the November Board of Supervisors meeting.

As mentioned above, we will remove funded items like the courthouse chiller, paving at the animal shelter, and other similar items. We are still awaiting word on the AFG grant which will impact future requests for Fire/Rescue, and hope to know the outcome of that grant request any day now. We anticipate adding the county share of the broadband project as a new project. Any input from the Finance Committee as we begin this update process is appreciated.

Clarke County Capital Improvement Plan 2021-2026

<u>Department</u>	<i>Projects by Department</i>	<u>2021-22</u> <u>Year 1</u>	<u>2022-23</u> <u>Year 2</u>	<u>2023-24</u> <u>Year 3</u>	<u>2024-25</u> <u>Year 4</u>	<u>2025-26</u> <u>Year 5</u>
Animal Shelter	Pave Roadway and Parking Lot	\$ -	\$ -	\$ -	\$ -	\$ 30,000
	Total	\$ -	\$ -	\$ -	\$ -	\$ 30,000
Fire & Rescue	Radio System Updgrade-Repeaters	\$ 430,000	\$ -	\$ -	\$ -	\$ -
	Radio Replacement	\$ 600,000	\$ -	\$ -	\$ -	\$ -
	SCBA's	\$ 200,000	\$ 200,000	\$ -	\$ -	\$ -
	Cardiac Monitors	\$ -	\$ -	\$ 50,000	\$ 50,000	\$ 50,000
	Apparatus	\$ 50,000	\$ 50,000	\$ 50,000	\$ 50,000	\$ 50,000
	Total	\$ 1,280,000	\$ 250,000	\$ 100,000	\$ 100,000	\$ 100,000
Health/Human Services	New Building and/or Space	\$ -	\$ -	\$ -	\$ -	\$ 1,500,000
	Total	\$ -	\$ -	\$ -	\$ -	\$ 1,500,000
Judicial	Circuit Court Chiller	\$ 225,000	\$ -	\$ -	\$ -	\$ -
	Reconfigure Circuit Court Courtroom	\$ -	\$ -	\$ -	\$ 100,000	\$ -
	Total	\$ 225,000	\$ -	\$ -	\$ 100,000	\$ -
Parks & Recreation	Soccer field grading/parking lot addition		\$ 75,000	\$ -	\$ -	\$ -
	Zero Entry for Pool	\$ -	\$ -	\$ 150,000	\$ -	\$ -
	New baseball field	\$ -	\$ -	\$ -	\$ 125,000	\$ -
	Shelter/restrooms for soccer	\$ -	\$ -	\$ -	\$ -	\$ 80,000
	Total	\$ -	\$ 75,000	\$ 150,000	\$ 125,000	\$ 80,000
Sheriff	Replacement Vehicles	\$ 171,000	\$ 173,000	\$ 175,000	\$ 177,000	\$ 179,000
	Replacement Radios	\$ 50,000	\$ 50,000	\$ 50,000	\$ 50,000	\$ 50,000
	NextGen 911 system upgrade	\$ -	\$ 150,000	\$ -	\$ -	\$ -
	Total	\$ 221,000	\$ 373,000	\$ 225,000	\$ 227,000	\$ 229,000
Transportation	Pedestrian Bridge Route 7 App Trail	\$ -	\$ -	\$ -	\$ -	TBD
	Total	\$ -	\$ -	\$ -	\$ -	TBD
	Total	\$ 1,726,000	\$ 698,000	\$ 475,000	\$ 552,000	\$ 1,939,000

FY 23 BUDGET CALENDAR

Draft

Date	Time	Location	Event
Monday, November 8, 2021	10:00 AM	JGC	BOS provides general direction to staff
Month of December			Meetings with Department Heads/Constitutional Officers and County Administrator/Finance Director
Mid-December			Munis opens for department budget input
Wednesday, January 12, 2022	08:30 AM	317 West Main	Finance Committee: School Finance Invitation**
Friday, January 14, 2022	05:00 PM		Department budgets due in Munis
Monday, January 31, 2022	09:30 AM	JGC	Staff Revenue Review
Tuesday, February 08, 2022	09:30 AM	JGC	Staff Revenue Review
Tuesday, February 15, 2022	05:30 PM	JGC	Finance Committee-Revenue Summary
Wednesday, February 16, 2022	08:30 AM	317 West Main	Finance Committee: School Finance Invitation**
Thursday, February 17, 2022	05:30 PM	JGC	Finance Committee-Expenditure Summary (Internal Presentations)
Tuesday, February 22, 2022	05:30 PM	JGC	Finance Committee-Revenue Follow-up
Thursday, February 24, 2022	05:30 PM	JGC	Finance Committee - Outside Agency Presentations
Tuesday, March 01, 2022	05:30 PM	JGC	Finance Committee-Balanced Budget Presented
Monday, March 07, 2022	06:30 PM	JGC	BOS Worksession: SB presentation
Tuesday, March 08, 2022	05:30 PM	JGC	Finance Committee-Finalize Revenues
Thursday, March 10, 2022	05:30 PM	JGC	Finance Committee-Finalize Expenditures
Tuesday, March 15, 2022	01:00 PM	JGC	BOS Authorization of public hearing
Monday, March 28, 2022	NA	Winchester Star	Advertise in newspaper (if needed)
Monday, April 04, 2022	NA	Winchester Star	Advertise in newspaper.
Monday, April 11, 2022	06:30 PM	TBD	Public Hearing (Jointly with School Board)
Tuesday, April 19, 2022	06:30 PM	JGC	BOS adopt budget and Appropriations Resolutions.

** pending School Board approval of their meeting calendar

Clarke County
 Invoice History Report
 September 30, 2021

VENDOR NAME	ACCOUNT DESC	FULL DESC	INVOICE DATE	AMOUNT
ABC CHECK PRINTING	Clk of CC Mat & Sup	DEPOSIT TICKETS, 8 BOOKS	08/31/2021	158.24
ABC CHECK PRINTING Total				158.24
Amazon Acct	Clk of CC Mat & Sup	OFFICE SUPPLIES, typewriter ri	08/06/2021	69.52
Amazon Acct	Comm Atty Mat & Sup	smartbuy 200	08/26/2021	34.89
Amazon Acct	Sheriff COS Mat & Sup	credit memo	08/26/2021	-13.97
Amazon Acct	Sheriff SOS Mat & Sup	Binders	08/25/2021	121.00
Amazon Acct	Sheriff SOS Mat & Sup	Fingerprint cards	08/23/2021	40.00
Amazon Acct	EMS Mat & Sup	safeco, desk organizer	09/02/2021	71.43
Amazon Acct	Parks Adm Mat & Sup	Projector	08/24/2021	349.99
Amazon Acct	Rec Center Mat & Sup	Projector	08/24/2021	200.00
Amazon Acct	Programs Mat & Sup	Projector	08/24/2021	200.00
Amazon Acct	Sheriff Mat & Sup	DTF Laptop	09/01/2021	779.95
Amazon Acct Total				1,852.81
American Tower	Sheriff Leases & Rentals	brt tower, transmittal, Antennae Lease	09/01/2021	2,380.50
American Tower Total				2,380.50
Animal Medical Ctr.	AnimalCtrl Pur Svcs	rm Animal Med ACO eye surgery on cat	09/03/2021	75.00
Animal Medical Ctr. Total				75.00
Apple Valley Waste	SWC Pur Svcs	rm Apple Valley Waste CCCC Recycling Fee	08/08/2021	1.00
Apple Valley Waste	SWC Pur Svcs	rm Apple Valley Waste CCCC Recycling Fee	08/15/2021	20.00
Apple Valley Waste	SWC Pur Svcs	rm Apple Valley Waste CCCC Recycling Fee	08/31/2021	21.20
Apple Valley Waste	SWC Pur Svcs	rm AppleValley Waste CCCC Recycling Fee	09/12/2021	56.80
Apple Valley Waste	SWC Pur Svcs	rm AppleValley Waste CCCC Recycling Fee	09/19/2021	1.00
Apple Valley Waste Total				100.00
At&t	County Adm Telephone	Cell Phones-School/Gov Acct 28	09/18/2021	46.69
At&t	IT Telephone	Cell Phones-School/Gov Acct 28	09/18/2021	84.93
At&t	Registrar Telephone	Cell Phones-School/Gov Acct 28	09/18/2021	46.69
At&t	Comm Atty Telephone	Cell Phones-School/Gov Acct 28	09/18/2021	167.04
At&t	Sheriff Telephone	Monthly Statement	09/01/2021	72.48
At&t	Sheriff Telephone	Cell Phones-School/Gov Acct 28	09/18/2021	1,816.68
At&t	Bldg Insp Telephone	Cell Phones-School/Gov Acct 28	09/18/2021	244.44
At&t	SWC Telephone	Cell Phones-School/Gov Acct 28	09/18/2021	41.86
At&t	Maintenanc Telephone	Cell Phones-School/Gov Acct 28	09/18/2021	46.30
At&t	Programs Telephone	Cell Phones-School/Gov Acct 28	09/18/2021	22.52
At&t	Econ Dev Telephone	Cell Phones-School/Gov Acct 28	09/18/2021	41.66
At&t	VictimWit Telephone	Cell Phones-School/Gov Acct 28	09/18/2021	41.66
At&t	EMS LEMPG Grant-Telephone	Cell Phones-School/Gov Acct 28	09/18/2021	538.98
At&t Total				3,211.93
Atlantic Tactical	Sheriff Ammunition	Yearly Ammo Order	09/01/2021	950.11
Atlantic Tactical	Sheriff Ammunition	Yearly Ammo Order	09/08/2021	598.56
Atlantic Tactical Total				1,548.67
Bank of America	JAS Finance Dues & Memb	UPPCC Recertification-Legge	08/31/2021	265.00
Bank of America Total				265.00
BB&T	BoS Pur Svcs	BRT FY22 August 2021 BB&T	09/09/2021	127.92
BB&T	BoS Travel	BRT FY22 August 2021 BB&T	09/09/2021	399.78
BB&T	BoS Dues & Memb	BRT FY22 August 2021 BB&T	09/09/2021	125.00
BB&T	County Adm Pur Svcs	BRT FY22 August 2021 BB&T	09/09/2021	1,090.44
BB&T	County Adm Travel	BRT FY22 August 2021 BB&T	09/09/2021	639.00
BB&T	County Adm Miscellaneous Expen	BRT FY22 August 2021 BB&T	09/09/2021	78.88
BB&T	IT Tech SW/OL	BRT FY22 August 2021 BB&T	09/09/2021	207.11
BB&T	Electoral Postal Svcs	Stamps for 11/2/2021 Vote by Mail Ballots	08/26/2021	220.00
BB&T	Sheriff Travel - Sworn Staff	Monthly Statement	09/09/2021	150.00
BB&T	Sheriff Travel - Sworn Staff	Monthly Statement	09/09/2021	5.26
BB&T	Sheriff Miscellaneous Expendit	Monthly Statement	09/09/2021	5.00
BB&T	Sheriff Dues & Memb	Statement	09/09/2021	248.98
BB&T	Sheriff PSU Mat & Sup	Statement	09/09/2021	167.75
BB&T	Sheriff SOS Mat & Sup	Monthly Statement	09/09/2021	105.19
BB&T	Sheriff SOS Mat & Sup	Statement	09/09/2021	496.38
BB&T	Sheriff VRP Mat & Sup	Statement	09/09/2021	121.84
BB&T	Sheriff Uniform Sworn Staff	Statement	09/09/2021	310.61
BB&T	Vol Fire Pur Svcs	Fire-EMS BB&T credit card statement 9-9-21	09/09/2021	44.17

Clarke County
 Invoice History Report
 September 30, 2021

VENDOR NAME	ACCOUNT DESC	FULL DESC	INVOICE DATE	AMOUNT
BB&T	EMS Travel	Fire-EMS BB&T credit card statement 9-9-21	09/09/2021	937.00
BB&T	EMS Miscellaneous	Fire-EMS BB&T credit card statement 9-9-21	09/09/2021	848.41
BB&T	EMS Mat & Sup	Fire-EMS BB&T Credit Card statement 9-9-21	09/09/2021	2,153.25
BB&T	AnimalCtrl Pur Svcs	rm BB&T Credit Card 08-12-21 to 09-5-2021	09/09/2021	499.19
BB&T	AnimalCtrl Mat & Sup	rm BB&T Credit Card 08-12-21 to 09-5-2021	09/09/2021	1,834.22
BB&T	Maintenanc Mat & Sup	rm BB&T Credit Card 08-12-21 to 09-5-2021	09/09/2021	381.29
BB&T	Parks Adm Printing & Binding	Business cards	08/27/2021	50.00
BB&T	Plan Adm Travel	VAZO 2021 Conference and Test Fee	09/09/2021	250.00
BB&T	Plan Adm Dues & Memb	VAZO 2021 Conference and Test Fee	09/09/2021	200.00
BB&T	JGC Maintenance Mat & Sup	rm BB&T Credit Card 08-12-21 to 09-5-2021	09/09/2021	345.85
BB&T	Sheriff Mat & Sup	Monthly STatement	09/09/2021	68.50
BB&T	Sheriff Mat & Sup	Statement	09/09/2021	431.84
BB&T	Maintenanc Mat & Sup	rm BB&T Credit Card 08-12-21 to 09-5-2021	09/09/2021	205.74
BB&T Total				12,748.60
Berkeley Club Bevera	County Adm Miscellaneous Expen	brt 9x5 gal water delivery	09/13/2021	64.55
Berkeley Club Bevera	Sheriff COS Mat & Sup	Water	09/10/2021	9.00
Berkeley Club Bevera	Sheriff SOS Mat & Sup	Water	09/10/2021	9.00
Berkeley Club Bevera	Maintenanc Water & Sewer	rm Berkeley Club Maint Cooler Rental for 9/2021	09/15/2021	11.00
Berkeley Club Bevera	Maintenanc Water & Sewer	rm Berkeley Club Maint Water	09/13/2021	19.50
Berkeley Club Bevera	County Adm Miscellaneous Expen	brt BCCGC Monthly Cooler Rental	09/14/2021	22.00
Berkeley Club Bevera	Comm Atty Mat & Sup	Water September 2021	09/13/2021	24.60
Berkeley Club Bevera	Sheriff COS Mat & Sup	Water	09/13/2021	32.50
Berkeley Club Bevera	Sheriff SOS Mat & Sup	Water	09/13/2021	26.00
Berkeley Club Bevera Total				218.15
Berryville Auto Part	Sheriff Pur Svcs	Sheriff's Office Vehicle Repair	08/26/2021	108.00
Berryville Auto Part	Sheriff Pur Svcs	Sheriff's Office Vehicle Repair	08/30/2021	63.13
Berryville Auto Part	Sheriff Pur Svcs	Sheriff's Office Vehicle Repair	08/31/2021	17.00
Berryville Auto Part	Sheriff Pur Svcs	Sheriff's Office Vehicle Repair - 1903	08/31/2021	195.00
Berryville Auto Part	Sheriff Pur Svcs	Sheriff's Office Vehicle Repair	09/04/2021	41.00
Berryville Auto Part	Sheriff VRP Mat & Sup	Sheriff's Office Vehicle Repair	08/26/2021	25.28
Berryville Auto Part	Sheriff VRP Mat & Sup	Sheriff's Office Vehicle Repair - 1701	08/30/2021	193.54
Berryville Auto Part	Sheriff VRP Mat & Sup	Sheriff's Office Vehicle Repair	08/31/2021	23.02
Berryville Auto Part	Sheriff VRP Mat & Sup	Sheriff's Office Vehicle Repair - 1903	08/31/2021	5.00
Berryville Auto Part	Sheriff VRP Mat & Sup	Sheriff's Office Vehicle Repair	09/04/2021	23.36
Berryville Auto Part	Maintenanc Mat & Sup	rm BAP Maint mount tire	08/20/2021	15.00
Berryville Auto Part	Maintenanc Mat & Sup	rm BAP Maint hi temp greas	08/23/2021	6.47
Berryville Auto Part	225Rams Maint Mat & Sup	rm BAP ACO mini light bulbs	08/31/2021	4.41
Berryville Auto Part	AlPool Maint Mat & Sup	rm BAP Pool Fuse for pizza machine	08/27/2021	1.92
Berryville Auto Part	Sheriff Pur Svcs	Sheriff's Office Vehicle Repair - 1803	09/14/2021	17.00
Berryville Auto Part	Sheriff Pur Svcs	Sheriff's Office Vehicle Repair - 1304	09/16/2021	126.00
Berryville Auto Part	Sheriff Pur Svcs	Sheriff's Office Vehicle Repair - 1401	09/20/2021	155.00
Berryville Auto Part	Sheriff Pur Svcs	Sheriff's Office Vehicle Repair	09/24/2021	41.00
Berryville Auto Part	Sheriff Pur Svcs	Sheriff's Office Vehicle Repair - 1304	09/16/2021	40.00
Berryville Auto Part	Sheriff Pur Svcs	Sheriff's Office Vehicle Report - 1404	09/24/2021	90.00
Berryville Auto Part	Sheriff Postal Svcs	UPS Shipment Package ID 34061	09/14/2021	26.17
Berryville Auto Part	Sheriff Postal Svcs	UPS Shipment Package ID 34062	09/14/2021	26.17
Berryville Auto Part	Sheriff Postal Svcs	UPS Package ID 34063	09/14/2021	26.17
Berryville Auto Part	Sheriff VRP Mat & Sup	Sheriff's Office Vehicle Repair - 1803	09/14/2021	33.60
Berryville Auto Part	Sheriff VRP Mat & Sup	Sheriff's Office Vehicle Repair - 1304	09/16/2021	296.17
Berryville Auto Part	Sheriff VRP Mat & Sup	Sheriff's Office Vehicle Repair - 1401	09/20/2021	151.79
Berryville Auto Part	Sheriff VRP Mat & Sup	Sheriff's Office Vehicle Repair	09/24/2021	32.44
Berryville Auto Part	Sheriff VRP Mat & Sup	Sheriff's Office Vehicle Repair - 1304	09/16/2021	0.62
Berryville Auto Part	Sheriff VRP Mat & Sup	Sheriff's Office Vehicle Report - 1404	09/24/2021	40.96
Berryville Auto Part	Maintenanc Mat & Sup	rm BAP Maint Building D Jeep Oil change	09/24/2021	33.90
Berryville Auto Part	Maintenanc Mat & Sup	rm BAP Maint washer fluid	09/28/2021	15.09
Berryville Auto Part Total				1,874.21
Berryville Farm	AnimalCtrl Mat & Sup	rm BFS ACO cat and dog food	08/19/2021	70.49
Berryville Farm Total				70.49
Berryville True Valu	Maintenanc Mat & Sup	rm BH Maint oil	08/18/2021	3.99
Berryville True Valu	Maintenanc Mat & Sup	rm BH maint paint tool and cover	08/23/2021	15.98

Clarke County
 Invoice History Report
 September 30, 2021

VENDOR NAME	ACCOUNT DESC	FULL DESC	INVOICE DATE	AMOUNT
Berryville True Valu	Rec Center Mat & Sup	supplies	08/30/2021	66.02
Berryville True Valu	JGC Maintenance Mat & Sup	rm BH 101 Chalmers Ct wall plate , work box	08/18/2021	4.08
Berryville True Valu	JGC Maintenance Mat & Sup	rm BH 101 Chalmers setter	08/19/2021	5.63
Berryville True Valu	JGC Maintenance Mat & Sup	rm BH 101 Charlmers Ct switch box ,	08/24/2021	7.08
Berryville True Valu	JGC Maintenance Mat & Sup	rm BH 101 Chalmers Ct joint compound	08/30/2021	11.28
Berryville True Valu	JGC Maintenance Mat & Sup	rm BH 101 Chalmers paint trays	09/03/2021	18.97
Berryville True Valu	JGC Maintenance Mat & Sup	rm BH 101 Chalmers Ct paint and cover	09/03/2021	7.20
Berryville True Valu	JGC Maintenance Mat & Sup	rm BH 101 Chalmers Ct batteries	09/07/2021	6.89
Berryville True Valu	ChurchSt Maint Mat & Sup	rm BH 102 N. Church lever . fill valve	08/23/2021	30.97
Berryville True Valu	ChurchSt Maint Mat & Sup	rm BH 102 N. Church toilet tank lever & valve	08/23/2021	7.00
Berryville True Valu	225Rams Maint Mat & Sup	rm BH ACO Mice traps and bait stations	08/25/2021	22.76
Berryville True Valu	Maintenanc Mat & Sup	rm BH 101 Chalmers setter	08/19/2021	3.35
Berryville True Valu	Maintenanc Mat & Sup	rm BH 101 Charlmers Ct switch box ,	08/24/2021	4.20
Berryville True Valu	Maintenanc Mat & Sup	rm BH 101 Chalmers Ct joint compound	08/30/2021	6.71
Berryville True Valu	Maintenanc Mat & Sup	rm BH 101 Chalmers paint trays	09/03/2021	11.28
Berryville True Valu	Maintenanc Mat & Sup	rm BH 101 Chalmers Ct paint and cover	09/03/2021	4.28
Berryville True Valu	Maintenanc Mat & Sup	rm BH 101 Chalmers Ct batteries	09/07/2021	4.10
Berryville True Valu	Maintenanc Mat & Sup	rm BH Maint stihl cyc oil	09/14/2021	11.94
Berryville True Valu	Maintenanc Mat & Sup	rm BH Maint Tool bag	09/14/2021	14.99
Berryville True Valu	Maintenanc Mat & Sup	rm BH Maint foam tray set	09/14/2021	9.99
Berryville True Valu	Maintenanc Mat & Sup	rm BH Maint paint brushes and broom for day of car	09/15/2021	54.95
Berryville True Valu	Maintenanc Mat & Sup	rm BH Maint scrubber brush	09/15/2021	4.49
Berryville True Valu	Maintenanc Mat & Sup	rm BH Maint cutter holder weld kit , coupling	09/16/2021	45.85
Berryville True Valu	Maintenanc Mat & Sup	rm BH Maint bit holder	09/21/2021	13.99
Berryville True Valu	Rec Center Mat & Sup	supplies	09/24/2021	20.46
Berryville True Valu	Rec Center Mat & Sup	supplies	09/24/2021	17.97
Berryville True Valu	Programs Mat & Sup	supplies	09/24/2021	37.98
Berryville True Valu	JGC Maintenance Mat & Sup	rm BH 101 Chalmers Ct putty and caulk	09/14/2021	5.94
Berryville True Valu	ChurchSt Maint Mat & Sup	rm BH 102 N. Church St toilet flapper	09/16/2021	10.99
Berryville True Valu	AIOff Maint Mat & Sup	rm BH CCHS Park bulb and plug	09/13/2021	5.99
Berryville True Valu	AIPool Maint Mat & Sup	rm BH Pool cap slip union ball valve	09/22/2021	21.97
Berryville True Valu	AIPool Maint Mat & Sup	rm BH Pool feddtube cutter	09/24/2021	17.99
Berryville True Valu	AIPool Maint Mat & Sup	rm BH Pool couplling Ell	09/24/2021	22.92
Berryville True Valu	Maintenanc Mat & Sup	rm BH 101 Chalmers Ct putty and caulk	09/14/2021	3.54
Berryville True Valu Total				563.72
BKT Uniforms	Sheriff Uniform Sworn Staff	Short Sleeved Shirts	08/23/2021	114.00
BKT Uniforms Total				114.00
Blue Ridge Volunteer	Vol Fire Co Insurance	For damage to ALS 8 Insurance	08/31/2021	1,041.57
Blue Ridge Volunteer	Vol Fire 4 for Life	Fire Programs funding 1-8.31.21	08/31/2021	2,414.59
Blue Ridge Volunteer	Vol Fire Fire Programs	Fire Programs funding 1-8.31.21	08/31/2021	6,442.29
Blue Ridge Volunteer	Vol Fire 4 for Life	4 for life funding-remaining balance	09/13/2021	3,662.42
Blue Ridge Volunteer Total				13,560.87
Blue360 Media	Comm Atty Mat & Sup	Law Books 09/2021	08/30/2021	380.12
Blue360 Media Total				380.12
BLUE360 MEDIA LLC	Clk of CC Mat & Sup	Police Crimes & Offenses	08/30/2021	190.06
BLUE360 MEDIA LLC Total				190.06
Bosserman, Barbara	Registrar Local Mileage	Travel to Shen. Co & Loudoun Co.	09/29/2021	76.72
Bosserman, Barbara Total				76.72
Broy & Son Pump	225Rams Maint Pur Svcs	rm Broy&Sons ACO Clogged sewer pump	08/20/2021	195.00
Broy & Son Pump Total				195.00
BSCM	Programs Pur Svcs	Contracted services-CCPRD Clas	09/10/2021	492.00
BSCM Total				492.00
Buckley, Randy	Plan Com Board Member Fees	PC Meetings 8/31/21 and 9/3/21	09/03/2021	100.00
Buckley, Randy Total				100.00
Caldwell, Anne	Plan Com Board Member Fees	PC Meetings 8/31/21 and 9/3/21	09/03/2021	100.00
Caldwell, Anne Total				100.00
Cardillo, Robin Couc	Cnsrv Esmt Donation Pur Svcs	Report prep and Aug ESMT Mtg, brochures, newsltr,	09/17/2021	1,280.00
Cardillo, Robin Couc Total				1,280.00
Carousel Industries	911 Phone Capital Outlay Repla	Next Gen 911 Proj SMS Carrier	09/16/2021	10,974.84
Carousel Industries Total				10,974.84

Clarke County
 Invoice History Report
 September 30, 2021

VENDOR NAME	ACCOUNT DESC	FULL DESC	INVOICE DATE	AMOUNT
Clarke County Health	Programs Pur Svcs	TB test	08/31/2021	14.42
Clarke County Health Total				14.42
CLARKE COUNTY HUMANE	General Overpayment Account	DONATION FROM MOLLY FOX	09/10/2021	80.00
CLARKE COUNTY HUMANE Total				80.00
Clarke County Sanita	COVWS Utilities	CARES - Utility Relief	09/13/2021	468.00
Clarke County Sanita Total				468.00
Clarke County Treasu	County Adm Mat & Sup	brt Bld Permit 210338 County Admin Office Remodel	09/07/2021	102.00
Clarke County Treasu	County Adm Mat & Sup	brt Bld Permit 210371 PATC Remodel	09/07/2021	102.00
Clarke County Treasu Total				204.00
Clean Water Pool	AlPool Maint Mat & Sup	rm Clean Water Pool	09/24/2021	49.50
Clean Water Pool Total				49.50
Combs Wastewater Man	AlOff Maint Pur Svcs	rm Combs Park Porta Potties 3	09/01/2021	210.00
Combs Wastewater Man Total				210.00
Comcast	IT Telecomm Online Tech	acct #8299610160035266 - 101 chalmers ct.	09/24/2021	220.10
Comcast	Sheriff Pur Svcs	acct #8299610160032289 100 N CHURCH ST.	09/27/2021	87.27
Comcast Total				307.37
Commercial Press	Com of Rev Pur Svcs	envelopes	09/01/2021	158.75
Commercial Press	Plan Adm Mat & Sup	Clarke County Planning Envelopes	08/27/2021	141.50
Commercial Press	Registrar Mat & Sup	Window Envelopes	08/13/2021	79.95
Commercial Press	AnimalCtrl Mat & Sup	rm Commerical Press ACO Adoption Contracts	09/03/2021	149.75
Commercial Press Total				529.95
ComputerPlus	IT Maint Contracts	AS400 Hardware Support	09/01/2021	127.00
ComputerPlus Total				127.00
Concise Systems	Reassess Prpty Tech SW/OL	Final Retainer CAMA migration & implementation	09/01/2021	14,784.00
Concise Systems Total				14,784.00
Cossette, Jennifer	Programs Pur Svcs	contracted employee	09/10/2021	675.00
Cossette, Jennifer Total				675.00
County of Frederick	RefuseDisp Intergov Svc Agreem	COUNTY RESIDENCE REFUSE ACCOUNT 08/2021	09/01/2021	1,095.16
County of Frederick	RefuseDisp Intergov Svc Agreem	NEW CITIZENS CENTER 08/2021	09/03/2021	1,412.62
County of Frederick	RefuseDisp Intergov Svc Agreem	VDOT - CLARKE 08/2021	09/03/2021	323.76
County of Frederick	RefuseDisp Intergov Svc Agreem	Sept bill for Aug charges Big shared Citizen site	09/21/2021	10,676.16
County of Frederick Total				13,507.70
CPI	Sheriff Maint Contracts	Annual OpenFox Maintenance 9/1/21 - 8/31/2022	09/17/2021	540.00
CPI Total				540.00
Crystal Springs	Parks Adm Leases & Rentals	water	09/07/2021	66.38
Crystal Springs Total				66.38
Daly Computers	IT Noncap Technology Hardware	memory modules	08/11/2021	235.00
Daly Computers	IT Noncap Technology Hardware	12 Lenovo monitors	08/26/2021	2,184.00
Daly Computers	IT Noncap Technology Hardware	USB speakers & headsets	09/07/2021	60.00
Daly Computers Total				2,479.00
DDL Business Sys	Clk of CC Maint Contracts	Copier Maint Sn: 7940-Circuit	08/25/2021	32.84
DDL Business Sys	Parks Adm Maint Contracts	Copier Maint. SN:3807-CCPRD	08/25/2021	7.50
DDL Business Sys	Parks Adm Maint Contracts	Copier Maint. SN:3807-CCPRD	08/25/2021	176.46
DDL Business Sys	Coop Ext Maint Contracts	Copier Maint. SN 1435-Coop. Ex	08/25/2021	125.22
DDL Business Sys	JAS IT Maint Contracts	Copier Maint. SN 9490-JAS	08/25/2021	80.50
DDL Business Sys	Clk of CC Maint Contracts	Copier Maint Sn: 7940-Circuit	09/25/2021	29.11
DDL Business Sys	Parks Adm Maint Contracts	Copier Maint. SN:3807-CCPRD	09/25/2021	66.44
DDL Business Sys	Coop Ext Maint Contracts	Copier Maint. SN 1435-Coop. Ex	09/25/2021	16.72
DDL Business Sys	JAS IT Maint Contracts	Copier Maint. SN 9490-JAS	09/25/2021	80.50
DDL Business Sys Total				615.29
Debbie Duvall	Programs Refunds	refund	09/22/2021	5.00
Debbie Duvall Total				5.00
Debora Mason	Pool Refunds	refund	09/14/2021	250.00
Debora Mason	Programs Refunds	refund	09/14/2021	36.00
Debora Mason Total				286.00
Department of State	Sheriff Pur Svcs	Employee Fingerprinting ID 48127 ACCT #A1928	09/01/2021	27.00
Department of State Total				27.00
DMV	Treasurer DMV Stop	DMV Stops - August 2021	08/31/2021	575.00
DMV Total				575.00
Doing Better Busines	Com of Rev Maint Contracts	Copier Maint: SN:0015: Treasur	09/08/2021	17.30

Clarke County
 Invoice History Report
 September 30, 2021

VENDOR NAME	ACCOUNT DESC	FULL DESC	INVOICE DATE	AMOUNT
Doing Better Busines	Treasurer Maint Contracts	Copier Maint: SN:0015: Treasur	09/08/2021	34.59
Doing Better Busines Total				51.89
Dunning, Buster	Plan Com Board Member Fees	PC Meetings 8/31/21 and 9/3/21	09/03/2021	100.00
Dunning, Buster Total				100.00
eCore Software Inc	EMS Tech SW/OL	Fire-EMS ePro scheduling lease Oct 2021	09/01/2021	187.00
eCore Software Inc Total				187.00
Floor Shop	JGC Maintenance Mat & Sup	rm Floor Shop 101 Chalmers Cove Base	08/17/2021	78.38
Floor Shop	Maintenanc Mat & Sup	rm Floor Shop 101 Chalmers Cove Base	08/17/2021	46.62
Floor Shop Total				125.00
FLYNN SEAN EDWARD	Personal Property Tax Current		09/15/2021	409.70
FLYNN SEAN EDWARD Total				409.70
Frederick-Winchester	Sanitation Intergov Svc Agreem	O&M RECOVERY COST	09/10/2021	2,616.49
Frederick-Winchester Total				2,616.49
Galls/Best Uniforms	EMS Clothing	Fire-EMS uniform badges	08/31/2021	218.50
Galls/Best Uniforms	Sheriff Uniform Sworn Staff	Badges and Name Tags	09/03/2021	439.84
Galls/Best Uniforms	Sheriff Uniform Sworn Staff	Carriers	09/03/2021	890.33
Galls/Best Uniforms Total				1,548.67
GCA Education Servic	Cooley MaintCustodial Contrctrs	rm ABM CUC Child Care	08/31/2021	324.00
GCA Education Servic	Maintenanc Custodial Contracts	rm ABM County Cleaning Sept 2021	09/01/2021	4,530.07
GCA Education Servic	JGC Maintenanc Custodial Contr	rm ABM County Cleaning Sept 2021	09/01/2021	1,187.75
GCA Education Servic	311EMain Maint Cus Contracts	rm ABM County Cleaning Sept 2021	09/01/2021	461.25
GCA Education Servic	Maintenanc Custodial Contracts	rm ABM County Cleaning Sept 2021	09/01/2021	706.59
GCA Education Servic Total				7,209.66
General Sales of Vir	Maintenanc Mat & Sup	rm General Sales disinfectant wipes and buckets	08/27/2021	612.00
General Sales of Vir Total				612.00
GeoConcepts Eng	Plan Adm Engineer & Architect	3rd party review of the CC Septic Ordinance	08/24/2021	2,000.00
GeoConcepts Eng Total				2,000.00
Glover, Robert P.	Plan Com Board Member Fees	PC Meetings 8/31/21 and 9/3/21	09/03/2021	100.00
Glover, Robert P. Total				100.00
Gnosis Solutions, In	Sheriff Pur Svcs	EDUCATIONAL/TRAINING SERVICES	09/28/2021	6,724.87
Gnosis Solutions, In Total				6,724.87
Grainger Inc	ChurchSt Maint Mat & Sup	rm Grainger 102 N. Church flush mat and gasket	08/23/2021	108.61
Grainger Inc	225Rams Maint Mat & Sup	rm Grainger ACO smoke dector photoelectric	09/22/2021	118.13
Grainger Inc	AIRec Maint Mat & Sup	rm Grainger Rec Senior Center Ice thickness probe	09/09/2021	106.17
Grainger Inc	AIOff Maint Mat & Sup	rm Grainger Park electronic timer for Tennis Court	09/20/2021	149.13
Grainger Inc Total				482.04
Hall, Monahan	BoS Pur Svcs	brt FY22 August Legal	09/02/2021	4,375.00
Hall, Monahan	Plan Adm Pur Svcs	brt FY22 August Legal	09/02/2021	743.50
Hall, Monahan	Dev Rights Pur Svcs	brt FY22 August Legal	09/02/2021	165.00
Hall, Monahan	Dev Rights Pur Svcs	Legal Services July - August 2021	09/02/2021	407.50
Hall, Monahan Total				5,691.00
Hershey Creamery	Concession Merch for Resale	ice cream	08/27/2021	187.98
Hershey Creamery Total				187.98
Holcomb, Kathy	Electoral Board Member Fees	Training Videos	09/27/2021	40.00
Holcomb, Kathy Total				40.00
Hunt, Pearce W	Plan Com Board Member Fees	PC Meetings 8/31/21 and 9/3/21	09/03/2021	100.00
Hunt, Pearce W Total				100.00
Innovative Access Te	RT Maint Mat & Sup	rm Innovative Tech 100 N. ECC troubleshoot door	08/20/2021	125.00
Innovative Access Te	311EMain Maint Pur Svcs	rm Innovative T 311 E Main alarm monitoring	09/01/2021	252.00
Innovative Access Te Total				377.00
Inova Occupational H	Vol Fire Pur Svcs	Fire-EMS NFPA physicals Aug 2021	09/03/2021	1,191.59
Inova Occupational H Total				1,191.59
Intab	Electoral Mat & Sup	Equipment Seals	08/30/2021	85.62
Intab Total				85.62
JK Enterprise	AIOff Maint Mat & Sup	rm JKEnterprise Park totlot chips	09/09/2021	2,130.00
JK Enterprise Total				2,130.00
John H Enders Fire	Enders Volunteer Fire Co Contr	Stipend Q2 FY22	09/21/2021	22,500.00
John H Enders Fire Total				22,500.00
JPMORGAN CHASE BANK	Personal Property Tax Current		09/21/2021	271.17
JPMORGAN CHASE BANK Total				271.17

Clarke County
 Invoice History Report
 September 30, 2021

VENDOR NAME	ACCOUNT DESC	FULL DESC	INVOICE DATE	AMOUNT
KNS Technologies	Econ Dev Maint Svc Contracts	Website Development (Tourism,	09/13/2021	150.00
KNS Technologies Total				150.00
Kruhm, Douglas	Plan Com Board Member Fees	PC Meeting 8/31/21	09/03/2021	50.00
Kruhm, Douglas Total				50.00
Kustom Signals Inc	Sheriff Pur Svcs	Cloud Service File Sharing	07/19/2021	200.00
Kustom Signals Inc	Sheriff Pur Svcs	Tuning Fork Certification	06/07/2021	24.00
Kustom Signals Inc Total				224.00
Language Line Servc	Sheriff Pur Svcs	Over the phone interpretation	08/31/2021	200.35
Language Line Servc Total				200.35
Latoya Franks	Programs Refunds	refund	09/09/2021	44.00
Latoya Franks Total				44.00
Lawrence Perry	Circuit Court Chiller Replace	A/E Services: Chiller Replacem	08/25/2021	7,500.00
Lawrence Perry Total				7,500.00
Lee, Frank	Plan Com Board Member Fees	PC Meetings 8/31/21 and 9/3/21	09/03/2021	100.00
Lee, Frank Total				100.00
Legal Directories Pu	Clk of CC Mat & Sup	VA Legal Directory 2021-2022	09/20/2021	59.75
Legal Directories Pu Total				59.75
Lewin Yount	129Rams Maint Pur Svcs	rm Lewin-Yount 129 Ramsburg Purchasing lift master	09/23/2021	1,400.00
Lewin Yount Total				1,400.00
LexisNexis	Sheriff Pur Svcs	Monthly Service	08/31/2021	150.00
LexisNexis Total				150.00
Live Action Safety	EMS Mat & Sup	Fire-EMS part of supply order July 2021	08/25/2021	2,190.26
Live Action Safety Total				2,190.26
Logan Systems Inc	Clk of CC Microfilming	Indexing - August 2021	09/15/2021	605.80
Logan Systems Inc Total				605.80
Lord Fairfax Commun	Lord FairfaxComm College Cont	FY22 Q1 Allocation	09/02/2021	4,491.25
Lord Fairfax Commun Total				4,491.25
Lord Fairfax Health	Local Health Dept Contribution	FY2022 Q2 Allocation	09/01/2021	48,410.50
Lord Fairfax Health Total				48,410.50
Lowes	Maintenanc Mat & Sup	rm Lowes Park treated treated Main tools	09/02/2021	204.19
Lowes	Maintenanc Mat & Sup	rm Lowes Maint 13" black square edge	09/08/2021	94.96
Lowes	Maintenanc Mat & Sup	rm Lowes Maint Tools for Brady	09/13/2021	312.79
Lowes	Maintenanc Mat & Sup	rm Lowes Maint Return impact 3/8	09/13/2021	-141.53
Lowes	AIOff Maint Mat & Sup	rm Lowes Park treated treated Main tools	09/02/2021	71.55
Lowes	Maintenanc Mat & Sup	rm Lowes Maint tools for Brady	09/14/2021	24.67
Lowes Total				566.63
Mallory Safety	EMS Mat & Sup	Fire-EMS PPE supplies	08/25/2021	475.00
Mallory Safety Total				475.00
Malone, Gwendolyn	Plan Com Board Member Fees	PC Meetings 8/31/21 and 9/3/21	09/03/2021	100.00
Malone, Gwendolyn Total				100.00
Mansfield Oil Co	County Adm Vehicle Fuel	rm Mansfled Oil Fuel 8/16/21-8/31/21	08/31/2021	94.13
Mansfield Oil Co	Sheriff Vehicle Fuel	Fuel for 8/16/2021 - 8/31/2021	08/31/2021	2,508.29
Mansfield Oil Co	EMS Vehicle Fuel	rm Mansfled Oil Fuel 8/16/21-8/31/21	08/31/2021	940.04
Mansfield Oil Co	Bldg Insp Vehicle Fuel	rm Mansfled Oil Fuel 8/16/21-8/31/21	08/31/2021	105.42
Mansfield Oil Co	AnimalCtrl Vehicle Fuel	rm Mansfled Oil Fuel 8/16/21-8/31/21	08/31/2021	40.00
Mansfield Oil Co	Maintenanc Vehicle Fuel	rm Mansfled Oil Fuel 8/16/21-8/31/21	08/31/2021	337.68
Mansfield Oil Co	Parks Adm Vehicle Fuel	rm Mansfled Oil Fuel 8/16/21-8/31/21	08/31/2021	61.58
Mansfield Oil Co	County Adm Vehicle Fuel	rm Mansfield Oil County Fuel 9-1 to 9-15-2021	09/15/2021	107.54
Mansfield Oil Co	Sheriff Vehicle Fuel	Fuel for 9/1 - 9/15/2021	09/15/2021	2,394.97
Mansfield Oil Co	EMS Vehicle Fuel	rm Mansfield Oil County Fuel 9-1 to 9-15-2021	09/15/2021	1,023.55
Mansfield Oil Co	Bldg Insp Vehicle Fuel	rm Mansfield Oil County Fuel 9-1 to 9-15-2021	09/15/2021	91.65
Mansfield Oil Co	AnimalCtrl Vehicle Fuel	rm Mansfield Oil County Fuel 9-1 to 9-15-2021	09/15/2021	60.42
Mansfield Oil Co	Maintenanc Vehicle Fuel	rm Mansfield Oil County Fuel 9-1 to 9-15-2021	09/15/2021	234.72
Mansfield Oil Co	Parks Adm Vehicle Fuel	rm Mansfield Oil County Fuel 9-1 to 9-15-2021	09/15/2021	8.51
Mansfield Oil Co Total				8,008.50
Marconi, Gloria	Cnsrv Esmt Donation Pur Svcs	Design/production of Summer 2021 CEA Newsletter	08/31/2021	450.00
Marconi, Gloria	Cnsrv Esmt Donation Pur Svcs	revisions to ESMT thank you event	09/20/2021	75.00
Marconi, Gloria Total				525.00
Marple, Beth	VictimWit Travel	VW Director's Forum--Roanoke, VA	09/01/2021	227.56
Marple, Beth Total				227.56

Clarke County
 Invoice History Report
 September 30, 2021

VENDOR NAME	ACCOUNT DESC	FULL DESC	INVOICE DATE	AMOUNT
Maurice Electrical	Maintenanc Mat & Sup	rm Maurice Maint electrical supplies wire nuts	08/10/2021	147.72
Maurice Electrical Total				147.72
McCormick Paint Work	AIOff Maint Mat & Sup	rm McCormick Paint Park paint for dugouts	09/13/2021	181.55
McCormick Paint Work	AI Soc Maint Mat & Sup	rm McCormick Paint Soccer Athletic Paint	09/15/2021	1,442.52
McCormick Paint Work Total				1,624.07
McDonald, Patricia	Sheriff Travel - Communication	Milage for Training in Harrisburg PA	09/27/2021	142.24
McDonald, Patricia Total				142.24
Meyercord Revenue	Treasurer Pur Svcs	Monthly Direct to Distributer	08/30/2021	25.00
Meyercord Revenue	Treasurer Mat & Sup	Cigarette Stamps	09/01/2021	2,250.00
Meyercord Revenue Total				2,275.00
Miles, Nicole	Comm Atty Travel	Nicole--Drug Court Conference August 2021	08/27/2021	73.76
Miles, Nicole Total				73.76
Miller, Sue	Programs Pur Svcs	Chair Yoga Classes	09/15/2021	150.15
Miller, Sue Total				150.15
Millers Supplie(B-K)	Clk of CC Mat & Sup	EXPANDING WALLETS (12)	09/10/2021	81.00
Millers Supplie(B-K) Total				81.00
Montgomery, Christel	Programs Pur Svcs	Contracted employee	09/10/2021	196.88
Montgomery, Christel Total				196.88
Narrow Passage Press	Programs Printing & Binding	printing program guide	08/19/2021	1,076.64
Narrow Passage Press Total				1,076.64
National Elevator	JGC Maintenanc Pur Svcs	rm NEIS 101 Chalmers Ct & 317 W. Main Elevator Ins	09/09/2021	53.30
National Elevator	Maintenanc Pur Svcs	rm NEIS 101 Chalmers Ct & 317 W. Main Elevator Ins	09/09/2021	31.70
National Elevator Total				85.00
NEISES DANIEL R	Personal Property Tax Current		09/21/2021	186.12
NEISES DANIEL R Total				186.12
Norvac Lock Tech	JGC Maintenance Mat & Sup	rm Norvac 101 Chalmers keys cut	09/24/2021	17.56
Norvac Lock Tech	Maintenanc Mat & Sup	rm Norvac 101 Chalmers keys cut	09/24/2021	10.44
Norvac Lock Tech Total				28.00
NRADC	Regional Jail Joint Ops		09/01/2021	127,494.50
NRADC Total				127,494.50
Office Depot	JAS Inventory -Mtls & Supplies	Central Store Supplies	09/03/2021	201.65
Office Depot	JAS Inventory -Mtls & Supplies	Central Store Supplies	09/03/2021	80.97
Office Depot Total				282.62
Ohrstrom, George II	Plan Com Board Member Fees	PC Meetings 8/31/21	09/03/2021	50.00
Ohrstrom, George II Total				50.00
Omnicom Consulting	Radio System Study Pur Svcs	radio project	09/01/2021	1,618.40
Omnicom Consulting Total				1,618.40
Our Health Inc	Our Health Entity Gift	Q1 21-22 Grant	08/01/2021	1,625.00
Our Health Inc Total				1,625.00
Patty Miller	Rec Center Refunds	refund	09/02/2021	80.00
Patty Miller Total				80.00
PEARTREE TIFFANY ANN	Personal Property Tax Current		09/15/2021	101.44
PEARTREE TIFFANY ANN Total				101.44
Pitney Bowes	BoS Mat & Sup	Postage machine ink	08/27/2021	35.44
Pitney Bowes	Com of Rev Mat & Sup	Postage machine ink	08/27/2021	35.44
Pitney Bowes	Treasurer Mat & Sup	Postage machine ink	08/27/2021	71.87
Pitney Bowes	IT Leases & Rentals	mailing machine quarterly lease	08/26/2021	1,040.04
Pitney Bowes	Registrar Mat & Sup	Postage machine ink	08/27/2021	35.44
Pitney Bowes	District C Postal Svcs	Mailing Machine Lease-Gen Dist	08/26/2021	145.29
Pitney Bowes	J&D Court Maint Contracts	JDR COURT METER CLARKE CO VA	08/26/2021	94.92
Pitney Bowes	Parks Adm Mat & Sup	Postage machine ink	08/27/2021	35.44
Pitney Bowes	JAS Finance Postal Svcs	Postage SBO office	09/05/2021	210.10
Pitney Bowes	Sheriff Postal Svcs	Postage Meter	09/11/2021	90.46
Pitney Bowes Total				1,794.44
Police and Sheriffs	EMS Miscellaneous	Fire-EMS ID cards	09/08/2021	32.55
Police and Sheriffs	EMS Miscellaneous	Fire-EMS ID cards	09/09/2021	219.15
Police and Sheriffs Total				251.70
PowerPhone Inc	Sheriff Travel - Communication	wier online training	09/14/2021	729.00
PowerPhone Inc Total				729.00
PowerSecure Service	JGC Maintenanc Pur Svcs	rm PowerSecure Generator Ser. Minor Town Wing	08/23/2021	94.05

Clarke County
 Invoice History Report
 September 30, 2021

VENDOR NAME	ACCOUNT DESC	FULL DESC	INVOICE DATE	AMOUNT
PowerSecure Service	JGC Maintenanc Pur Svcs	rm PowerSecure Generator Ser. Minor County Wing	08/23/2021	94.05
PowerSecure Service	JGC Maintenanc Pur Svcs	rm PowerSecure Generator Ser. Minor Library Wing	08/23/2021	94.05
PowerSecure Service	JGC Maintenanc Pur Svcs	rm PowerSecure 101 Chalmers Generator Repair Count	09/08/2021	231.99
PowerSecure Service	RT Maintenanc Pur Svcs	rm PowerSecure 100N Tower Generator Repair	09/08/2021	490.00
PowerSecure Service	AIRec Maint Pur Svcs	rm Power Secure Rec C Generator Ser Minor	08/23/2021	160.00
PowerSecure Service	Maintenanc Pur Svcs	rm PowerSecure Generator Ser. Minor Town Wing	08/23/2021	55.95
PowerSecure Service	Maintenanc Pur Svcs	rm PowerSecure Generator Ser. Minor County Wing	08/23/2021	55.95
PowerSecure Service	Maintenanc Pur Svcs	rm PowerSecure Generator Ser. Minor Library Wing	08/23/2021	55.95
PowerSecure Service	Maintenanc Pur Svcs	rm PowerSecure 101 Chalmers Generator Repair Count	09/08/2021	138.01
PowerSecure Service Total				1,470.00
Premier Accounts Rec	EMS Pur Svcs	Premier Accts Rec-EMS billing invoice Aug 21	09/02/2021	2,887.63
Premier Accounts Rec Total				2,887.63
Printelect	Electoral Printing & Binding	11022021 Ballots	09/23/2021	2,604.61
Printelect Total				2,604.61
Purchase Power	BoS Telephone	Postage through 8/9/2021	09/03/2021	18.63
Purchase Power	County Adm Postal Svcs	Postage through 8/9/2021	09/03/2021	3.11
Purchase Power	Com of Rev Postal Svcs	Postage through 8/9/2021	09/03/2021	157.49
Purchase Power	Treasurer Postal Svcs	Postage through 8/9/2021	09/03/2021	1,612.82
Purchase Power	Electoral Postal Svcs	Postage through 8/9/2021	09/03/2021	6.04
Purchase Power	Registrar Postal Svcs	Postage through 8/9/2021	09/03/2021	341.70
Purchase Power	EMS Postal Services	Postage through 8/9/2021	09/03/2021	12.39
Purchase Power	Bldg Insp Postal Svcs	Postage through 8/9/2021	09/03/2021	18.11
Purchase Power	Plan Adm Postal Svcs	Postage through 8/9/2021	09/03/2021	274.07
Purchase Power	Coop Ext Postal Svcs	Postage through 8/9/2021	09/03/2021	63.13
Purchase Power Total				2,507.49
Radial Tire	Sheriff VRP Mat & Sup	Tires - 1801	08/31/2021	540.00
Radial Tire Total				540.00
Ramirez Landscape LI	SWC Pur Svcs	rm Ramirez Land County Mow Aug 2021	09/17/2021	70.00
Ramirez Landscape LI	Maintenanc Pur Svcs	rm Ramirez Land County Mow Aug 2021	09/17/2021	4,490.00
Ramirez Landscape LI Total				4,560.00
Rappahannock Electri	SWC Electrical Services	rm REC County Electric Bill0 8-1-2021 to 9-1-2021	09/07/2021	129.77
Rappahannock Electri	JGC Maintenanc Electric	rm REC County Electric Bill0 8-1-2021 to 9-1-2021	09/07/2021	2,574.56
Rappahannock Electri	RT Maintenanc Electric	rm REC County Electric Bill0 8-1-2021 to 9-1-2021	09/07/2021	1,115.65
Rappahannock Electri	ChurchSt Maint Electric	rm REC County Electric Bill0 8-1-2021 to 9-1-2021	09/07/2021	1,693.49
Rappahannock Electri	104Church Maint Electric	rm REC County Electric Bill0 8-1-2021 to 9-1-2021	09/07/2021	911.02
Rappahannock Electri	225Rams Maint Electric	rm REC County Electric Bill0 8-1-2021 to 9-1-2021	09/07/2021	911.74
Rappahannock Electri	524West Maint Electric	rm REC County Electric Bill0 8-1-2021 to 9-1-2021	09/07/2021	174.77
Rappahannock Electri	AIRec Maint Electric	rm REC County Electric Bill0 8-1-2021 to 9-1-2021	09/07/2021	2,401.08
Rappahannock Electri	AIOff Maint Electric	rm REC County Electric Bill0 8-1-2021 to 9-1-2021	09/07/2021	516.61
Rappahannock Electri	AIPool Maint Electric	rm REC County Electric Bill0 8-1-2021 to 9-1-2021	09/07/2021	1,574.39
Rappahannock Electri	AIBase Maint Electric	rm REC County Electric Bill0 8-1-2021 to 9-1-2021	09/07/2021	23.60
Rappahannock Electri	AI Soc Maint Electric	rm REC County Electric Bill0 8-1-2021 to 9-1-2021	09/07/2021	118.96
Rappahannock Electri	309WMain Maint Electrical Svcs	rm REC County Electric Bill0 8-1-2021 to 9-1-2021	09/07/2021	85.22
Rappahannock Electri	311EMain Maint Electric	rm REC County Electric Bill0 8-1-2021 to 9-1-2021	09/07/2021	603.66
Rappahannock Electri	129Rams Maint Electric	rm REC County Electric Bill0 8-1-2021 to 9-1-2021	09/07/2021	254.35
Rappahannock Electri	Maintenanc Electric	rm REC County Electric Bill0 8-1-2021 to 9-1-2021	09/07/2021	1,531.60
Rappahannock Electri Total				14,620.47
Republic Services	SWC Pur Svcs	Waste Services-School Dumpster	08/31/2021	5,814.80
Republic Services	LitterCtrl Pur Svcs	Gov't Dumpsters Acct 3-0976-00	08/31/2021	82.75
Republic Services	LitterCtrl Pur Svcs	Litter Bins JWMS/CCHS-Acct 3-0	08/31/2021	110.00
Republic Services	JGC Maint Contracts	Gov't Dumpsters Acct 3-0976-00	08/31/2021	83.89
Republic Services	Maintenanc Maint Contracts	Gov't Dumpsters Acct 3-0976-00	08/31/2021	49.91
Republic Services Total				6,141.35
Ricoh Usa	County Adm Maint Contracts	Copier Maint SN4662-Building D	08/20/2021	974.91
Ricoh Usa	Registrar Maint Contracts	Copier Maint SN4662-Building D	08/20/2021	476.12
Ricoh Usa	Comm Atty Maint Contracts	Copier Maint. SN:3777-Comm. At	09/20/2021	187.20
Ricoh Usa	Sheriff Maint Contracts	Copier Maint-SN8373-Sheriff	07/21/2021	317.40
Ricoh Usa	Bldg Insp Maint Contracts	Copier Maint SN4662-Building D	08/13/2021	403.79
Ricoh Usa	Plan Adm Maint Contracts	Copier Maint SN4662-Building D	08/20/2021	816.21
Ricoh Usa Total				3,175.63

Clarke County
 Invoice History Report
 September 30, 2021

VENDOR NAME	ACCOUNT DESC	FULL DESC	INVOICE DATE	AMOUNT
Riddleberger Bros	104Church Maint Pur Svcs	rm RBI 104 N.Church replace 2 compasitors found pm	09/15/2021	286.69
Riddleberger Bros Total				286.69
Rose, Janine	Sheriff Travel - Sworn Staff	Airfare and Ground Transportation for EA Summit	08/17/2021	693.32
Rose, Janine	Sheriff Travel - Sworn Staff	Meals and Hotel for APC Conference	09/27/2021	1,679.28
Rose, Janine Total				2,372.60
Roseville & Plaza Pe	AnimalCtrl Pur Svcs	rm Roseville Vet ACO Rabies shots meds and euthana	09/02/2021	373.34
Roseville & Plaza Pe Total				373.34
S&S Worldwide	Programs Mat & Sup	supplies	09/22/2021	60.61
S&S Worldwide Total				60.61
Safeware	EMS Miscellaneous	Fire-EMS replacement parts Kevlar masks	09/15/2021	5.64
Safeware Total				5.64
Schenck Foods Compan	Programs Mat & Sup	food	08/31/2021	210.35
Schenck Foods Compan Total				210.35
Secure Shred	Sheriff Pur Svcs	Monthly Shredding Service	09/01/2021	50.00
Secure Shred Total				50.00
Shallow Creek Electr	RT Maintenanc Pur Svcs	rm Shallow Creek 100 N.Church New EMU2 wiring	09/17/2021	520.00
Shallow Creek Electr	911 Phone Capital Outlay Repla	Electrical Wiring-100 North Ch	09/17/2021	1,176.00
Shallow Creek Electr Total				1,696.00
Shentel	IT Telecomm Online Tech	Government Shentel Dark Fiber	09/01/2021	2,313.28
Shentel	IT Leases & Rentals	Government Shentel Dark Fiber	09/01/2021	690.00
Shentel	Maintenanc Telephone	Government Shentel Dark Fiber	09/01/2021	121.58
Shentel Total				3,124.86
Southern Refrigerati	Maintenanc Mat & Sup	rm Southern Ref Maint tools for Brady	09/13/2021	405.49
Southern Refrigerati Total				405.49
SPEARS ELLEN WALLER	Personal Property Tax Current		09/02/2021	23.64
SPEARS ELLEN WALLER Total				23.64
SRFAX	IT Tech SW/OL	SR Fax web fax service	09/06/2021	126.91
SRFAX Total				126.91
Staples Technology S	JAS Inventory -Mtls & Supplies	Central Store-Writing Pads	08/13/2021	50.20
Staples Technology S	JAS Inventory -Mtls & Supplies	Binders for Central Store	09/03/2021	70.08
Staples Technology S	JAS Finance Mat & Sup	Pens and Notebooks	08/05/2021	32.59
Staples Technology S Total				152.87
Supply Room, The	District C Mat & Sup	PENS	08/13/2021	79.44
Supply Room, The Total				79.44
Swank Motion Picture	Programs Pur Svcs	purchased services	09/23/2021	305.00
Swank Motion Picture Total				305.00
TeamCraft Roofing	JGC Maintenanc Pur Svcs	rm TeamCraft 101 Chalmers Roof leak	08/24/2021	175.37
TeamCraft Roofing	JGC Maintenanc Pur Svcs	rm Teamcraft 101 Chalmers Ct roof repair	08/31/2021	225.19
TeamCraft Roofing	RT Maintenanc Pur Svcs	rm Teamcraft 100 N. Church roof leak	08/31/2021	87.50
TeamCraft Roofing	Maintenanc Pur Svcs	rm TeamCraft 101 Chalmers Roof leak	08/24/2021	104.33
TeamCraft Roofing	Maintenanc Pur Svcs	rm Teamcraft 101 Chalmers Ct roof repair	08/31/2021	133.96
TeamCraft Roofing Total				726.35
Thomson Reuters	Comm Atty Dues & Memb	September 2021	09/01/2021	38.32
Thomson Reuters Total				38.32
Touch of Glass	BoS Miscellaneous Expenditures	brt Service Award Engraving 2021	08/31/2021	220.48
Touch of Glass Total				220.48
Town of Berryville	JGC Maintenanc Water & Sewer	rm TOB Water and Sewer	08/23/2021	82.83
Town of Berryville	RT Maintenanc Water & Sewer	rm TOB Water and Sewer 100 N. Church St	08/23/2021	559.24
Town of Berryville	104Church Maint Water & Sewer	rm TOB Water and Sewer 104 N. Church St	08/23/2021	55.84
Town of Berryville	AIRec Maint Water & Sewer	rm TOB Water and Sewer Rec Center	08/23/2021	64.74
Town of Berryville	AIOff Maint Water & Sewer	rm TOB Water and Sewer Park LL	08/23/2021	18.75
Town of Berryville	AIOff Maint Water & Sewer	rm TOB Water and Sewer Park House	08/23/2021	234.14
Town of Berryville	AIPool Maint Water & Sewer	rm TOB Water and Sewer Pool	08/23/2021	2,667.84
Town of Berryville	309WMain Maint Water & Sewer	rm TOB Water and Sewer 309 W. Main St	08/23/2021	20.00
Town of Berryville	311EMain Maint Water & Sewer	rm TOB Water and Sewer 313 E. Main St	08/23/2021	20.00
Town of Berryville	311EMain Maint Water & Sewer	rm TOB Water and Sewer 311 E. Main St	08/23/2021	50.84
Town of Berryville	129Rams Maint Water & Sewer	rm TOB Water and Sewer 129 Ramsburg Ln	08/23/2021	21.58
Town of Berryville	Pyts to Town of Berryville	Local Sales Tax - June 2021 (Received August 2021)	08/31/2021	27,528.86
Town of Berryville	Maintenanc Water & Sewer	rm TOB Water and Sewer	08/23/2021	49.27
Town of Berryville	Court Fines & Forfeitures	Court Fines - July - August 2021	09/05/2021	190.00

Clarke County
 Invoice History Report
 September 30, 2021

VENDOR NAME	ACCOUNT DESC	FULL DESC	INVOICE DATE	AMOUNT
Town of Berryville	Pyts to Town of Berryville	Local Sales Tax - July 2021 (recvd Sept 2021)	09/27/2021	28,031.06
Town of Berryville Total				59,594.99
Town of Boyce	Pyts to Town of Boyce	Local Sales Tax - June 2021 (Received Aug 2021)	08/31/2021	3,803.33
Town of Boyce	Pyts to Town of Boyce	Local Sales Tax - July 2021 (recvd Sept 2021)	09/27/2021	3,876.64
Town of Boyce Total				7,679.97
Trinity Turf, Inc	AlBase Maint Mat & Sup	rm Trinity Turf Baseball marking lime mound clay	08/27/2021	592.50
Trinity Turf, Inc Total				592.50
Turiya	Sheriff Pur Svcs	Yoga Sessions	08/31/2021	510.00
Turiya Total				510.00
Tyler Technologies	Tech SW/OL	CAMA bridge development -- final 50%	07/30/2021	4,000.00
Tyler Technologies Total				4,000.00
US Postmaster	JAS Finance Postal Svcs	2 ROLLS OF FOREVER STAMPS FOR JAS	09/20/2021	116.00
US Postmaster Total				116.00
Valley Car Wash	Sheriff Pur Svcs	Car Wash	08/31/2021	188.80
Valley Car Wash Total				188.80
Valley Doors Unlimit	JGC Maintenance Mat & Sup	rm Valley Doors 101 Chalmers Ct 3070 frame	09/02/2021	331.06
Valley Doors Unlimit	Maintenanc Mat & Sup	rm Valley Doors 101 Chalmers Ct 3070 frame	09/02/2021	196.94
Valley Doors Unlimit Total				528.00
Valley Health	EMS Mat & Sup	Fire-EMS WMC supply invoice Aug 2021	09/01/2021	1,387.46
Valley Health Total				1,387.46
VANMETER GARY K	Personal Property Tax Current		09/02/2021	199.22
VANMETER GARY K Total				199.22
VANMETER SHEREE LYNN	Personal Property Tax Current		09/02/2021	2.16
VANMETER SHEREE LYNN Total				2.16
VCE-Clarke County	Programs Pur Svcs	contracted employee	09/10/2021	224.00
VCE-Clarke County Total				224.00
Verizon	County Adm Telephone	351320713000161,351692041000125,551692041000172	08/25/2021	12.00
Verizon	Com of Rev Telephone	351320713000161,351692041000125,551692041000172	08/25/2021	8.00
Verizon	Treasurer Telephone	351320713000161,351692041000125,551692041000172	08/25/2021	4.00
Verizon	IT Telephone	351320713000161,351692041000125,551692041000172	08/25/2021	371.70
Verizon	Registrar Telephone	351320713000161,351692041000125,551692041000172	08/25/2021	4.00
Verizon	District C Telephone	351320713000161,351692041000125,551692041000172	08/25/2021	56.17
Verizon	J&D Court Telephone	351320713000161,351692041000125,551692041000172	08/25/2021	55.02
Verizon	Clk of CC Telephone	351320713000161,351692041000125,551692041000172	08/25/2021	84.94
Verizon	Comm Atty Telephone	351320713000161,351692041000125,551692041000172	08/25/2021	16.00
Verizon	Sheriff Telephone	351320713000161,351692041000125,551692041000172	08/25/2021	302.12
Verizon	Sheriff Telephone	Central Alarm	09/01/2021	1,704.62
Verizon	Sheriff Telephone	Verizon Radio Tower	09/01/2021	49.17
Verizon	EMS Telephone	351320713000161,351692041000125,551692041000172	08/25/2021	48.02
Verizon	Probation Telephone	351320713000161,351692041000125,551692041000172	08/25/2021	4.00
Verizon	Bldg Insp Telephone	351320713000161,351692041000125,551692041000172	08/25/2021	8.00
Verizon	AnimalCtrl Telephone	351320713000161,351692041000125,551692041000172	08/25/2021	44.59
Verizon	Maintenanc Telephone	351320713000161,351692041000125,551692041000172	08/25/2021	44.59
Verizon	Parks Adm Telephone	351320713000161,351692041000125,551692041000172	08/25/2021	68.59
Verizon	Plan Adm Telephone	351320713000161,351692041000125,551692041000172	08/25/2021	12.00
Verizon	JAS Finance Telephone	351320713000161,351692041000125,551692041000172	08/25/2021	121.18
Verizon Total				3,018.71
VITA	IT Telephone	AUGUST PHONE BILL	09/01/2021	144.72
VITA	District C Telephone	AUGUST PHONE BILL	09/01/2021	112.87
VITA	J&D Court Telephone	AUGUST PHONE BILL	09/01/2021	1.10
VITA	Clk of CC Telephone	AUGUST PHONE BILL	09/01/2021	0.42
VITA	Sheriff Telephone	AUGUST PHONE BILL	09/01/2021	1,760.33
VITA	Maintenanc Telephone	AUGUST PHONE BILL	09/01/2021	66.71
VITA Total				2,086.15
Wage Works	Flex Bens Pur Svcs	Administrative fee for August	08/25/2021	491.00
Wage Works	Flex Bens Pur Svcs	Refund for overcharge on August	09/09/2021	-94.50
Wage Works	Flex Bens Pur Svcs	Administrative fee for September	09/23/2021	491.00
Wage Works	Flex Bens Pur Svcs	Credit for overcharge	09/27/2021	-94.50
Wage Works Total				793.00
Walmart	Programs Mat & Sup	supplies 9457	08/19/2021	36.92

Clarke County
 Invoice History Report
 September 30, 2021

VENDOR NAME	ACCOUNT DESC	FULL DESC	INVOICE DATE	AMOUNT
Walmart	Concession Merch for Resale	supplies 9457	08/19/2021	178.08
Walmart	Rec Center Mat & Sup	supplies	09/14/2021	65.98
Walmart	Rec Center Merch for Resale	supplies	09/14/2021	46.44
Walmart	Programs Mat & Sup	supplies	09/14/2021	79.46
Walmart	Concession Merch for Resale	supplies	09/14/2021	40.80
Walmart Total				447.68
WARNOCK BENJAMIN LEE	Personal Property Tax Current		09/15/2021	357.07
WARNOCK BENJAMIN LEE Total				357.07
Washington Gas	JGC Maintenanc Heating	101 CHALMERS CT 081321-091421	09/16/2021	39.69
Washington Gas	RT Maintenanc Heating	100 N CHURCH ST 081321-091421	09/16/2021	20.45
Washington Gas	104Church Maint Heating	104 N CHURCH ST 081321-091421	09/16/2021	20.45
Washington Gas	AlRec Maint Heating	225 AL SMITH CIR 081421-091521	09/17/2021	126.47
Washington Gas	Maintenanc Heating	101 CHALMERS CT 081321-091421	09/16/2021	23.61
Washington Gas Total				230.67
White, Rebecca	Sheriff Uniform Sworn Staff	Shoes	09/15/2021	104.93
White, Rebecca Total				104.93
Winchester Equipment	Maintenanc Mat & Sup	rm Winchester Equip Maint tire and rim for gator	08/23/2021	171.17
Winchester Equipment	Maintenanc Mat & Sup	rm Winchester Equip Maint return tire	09/13/2021	-156.17
Winchester Equipment	Maintenanc Mat & Sup	rm Winchester Equip Maint Tires for tractor	09/16/2021	368.28
Winchester Equipment Total				383.28
Winchester Printers	Cnsrv Esmt Donation Pur Svcs	Summer 21 printing and postage	09/16/2021	955.34
Winchester Printers Total				955.34
Winchester Star	BoS Advertising	brt PH2021-10 Notices	08/31/2021	961.28
Winchester Star Total				961.28
Wright Line Llc	Sheriff COS Mat & Sup	console lift arm replacement p	08/24/2021	305.15
Wright Line Llc Total				305.15
Grand Total				491,827.63

**Clarke County
YTD Budget Report
September 30, 2021**

FUNCTION	OBJECT	ACCOUNT DESCRIPTION	REVISED BUDGET	YTD EXPENDED	AVAILABLE BUDGET	% Used
00000	5800	APR CRF Miscellaneous Expense	2,832,226.00	-	2,832,226.00	0%
Total 00000 Non-Categorical			2,832,226.00	-	2,832,226.00	0%
11010	1300	BoS Part Time Salaries	13,800.00	3,550.00	10,250.00	26%
11010	2100	BoS FICA	957.00	244.67	712.33	26%
11010	2300	BoS Health Ins	15,922.00	3,980.28	11,941.72	25%
11010	2700	BoS Worker's Comp	-	11.00	(11.00)	100%
11010	3000	BoS Pur Svcs	1,500.00	4,825.40	(3,325.40)	322%
11010	3600	BoS Advertising	5,600.00	1,141.52	4,458.48	20%
11010	5210	BoS Postal Services	500.00	-	500.00	0%
11010	5230	BoS Telephone	35.00	18.63	16.37	53%
11010	5300	BoS Insurance	6,000.00	3,929.00	2,071.00	65%
11010	5500	BoS Travel	4,000.00	399.78	3,600.22	10%
11010	5800	BoS Miscellaneous Expenditures	2,200.00	359.93	1,840.07	16%
11010	5810	BoS Dues & Memb	5,500.00	4,041.00	1,459.00	73%
11010	6000	BoS Mat & Sup	800.00	35.44	764.56	4%
Total 11010 Board of Supervisors			56,814.00	22,536.65	34,277.35	40%
12110	1100	County Adm Salaries	246,452.00	61,613.01	184,838.99	25%
12110	1300	County Adm Part Time Salaries	69,000.00	11,665.50	57,334.50	17%
12110	2100	County Adm FICA	23,694.00	5,643.69	18,050.31	24%
12110	2210	County Adm VRS 1&2	15,373.00	3,843.18	11,529.82	25%
12110	2220	County Adm VRS Hybrid	10,993.00	2,515.26	8,477.74	23%
12110	2300	County Adm Health Ins	15,922.00	3,980.28	11,941.72	25%
12110	2400	County Adm Life Ins	3,304.00	825.63	2,478.37	25%
12110	2510	County Adm Dis Ins Hybrid	516.00	128.70	387.30	25%
12110	2700	County Adm Workers Comp	284.00	248.10	35.90	87%
12110	3000	County Adm Pur Svcs	2,000.00	1,484.39	515.61	74%
12110	3320	County Adm Maint Contracts	1,500.00	1,131.26	368.74	75%
12110	3500	County Adm Printing & Binding	700.00	-	700.00	0%
12110	5210	County Adm Postal Svcs	50.00	3.11	46.89	6%
12110	5230	County Adm Telephone	800.00	176.07	623.93	22%
12110	5500	County Adm Travel	2,500.00	639.00	1,861.00	26%
12110	5800	County Adm Miscellaneous Expen	500.00	498.32	1.68	100%
12110	5810	County Adm Dues & Memb	1,800.00	463.58	1,336.42	26%
12110	6000	County Adm Mat & Sup	2,300.00	1,139.49	1,160.51	50%
12110	6008	County Adm Vehicle Fuel	1,200.00	413.23	786.77	34%
Total 12110 County Administrator			398,888.00	96,411.80	302,476.20	24%
12120	1100	Inform Salaries - Regular	42,051.00	10,512.75	31,538.25	25%
12120	2100	Inform FICA	3,164.00	795.31	2,368.69	25%
12120	2220	Inform VRS Hybrid	4,552.00	1,084.89	3,467.11	24%
12120	2300	Inform Health Ins	7,961.00	1,990.14	5,970.86	25%
12120	2400	Inform Life Ins	564.00	140.88	423.12	25%
12120	2510	Inform Dis Ins Hybrid	223.00	55.50	167.50	25%
12120	2700	Inform Workers Comp	38.00	33.00	5.00	87%
12120	3000	Inform Pur Svcs	5,000.00	4,788.00	212.00	96%
12120	5210	Inform Postal Svcs	100.00	-	100.00	0%
12120	5230	Inform Telephone	200.00	-	200.00	0%
12120	5500	Inform Travel	500.00	-	500.00	0%
12120	6000	Inform Mat & Sup	500.00	-	500.00	0%
Total 12120 Public Information Serv			64,853.00	19,400.47	45,452.53	30%
12210	3000	Legal Svc Pur Svcs	25,000.00	122.50	24,877.50	0%
Total 12210 Legal Services			25,000.00	122.50	24,877.50	0%
12310	1100	Com of Rev Salaries	166,040.00	40,461.13	125,578.87	24%
12310	2100	Com of Rev FICA	11,583.00	2,883.01	8,699.99	25%
12310	2210	Com of Rev VRS 1&2	12,915.00	3,228.42	9,686.58	25%
12310	2220	Com of Rev VRS Hybrid	4,428.00	1,055.43	3,372.57	24%
12310	2300	Com of Rev Health Ins	17,376.00	4,344.00	13,032.00	25%
12310	2400	Com of Rev Life Ins	2,227.00	556.23	1,670.77	25%
12310	2510	Com of Rev Dis Ins Hybrid	216.00	54.00	162.00	25%
12310	2700	Com of Rev Workers Comp	149.00	130.53	18.47	88%
12310	2800	Com of Rev Leave Payouts	-	644.91	(644.91)	100%
12310	3000	Com of Rev Pur Svcs	1,400.00	869.52	530.48	62%
12310	3320	Com of Rev Maint Contracts	300.00	47.71	252.29	16%
12310	3500	Com of Rev Printing & Binding	300.00	-	300.00	0%

**Clarke County
YTD Budget Report
September 30, 2021**

FUNCTION	OBJECT	ACCOUNT DESCRIPTION	REVISED BUDGET	YTD EXPENDED	AVAILABLE BUDGET	% Used
12310	4100	Com of Rev Data Processing	2,100.00	2,750.00	(650.00)	131%
12310	5210	Com of Rev Postal Svcs	2,000.00	271.49	1,728.51	14%
12310	5230	Com of Rev Telephone	200.00	24.00	176.00	12%
12310	5500	Com of Rev Travel	2,000.00	-	2,000.00	0%
12310	5510	Com of Rev Local Mileage	150.00	-	150.00	0%
12310	5810	Com of Rev Dues & Memb	800.00	135.00	665.00	17%
12310	6000	Com of Rev Mat & Sup	1,000.00	126.94	873.06	13%
12310	6035	Com of Rev Noncap Ofc Equip	-	-	-	100%
Total 12310 Commissioner of Revenue			225,184.00	57,582.32	167,601.68	26%
12410	1100	Treasurer Salaries	204,153.00	43,443.84	160,709.16	21%
12410	2100	Treasurer FICA	14,694.00	3,234.27	11,459.73	22%
12410	2210	Treasurer VRS 1&2	13,289.00	2,578.34	10,710.66	19%
12410	2220	Treasurer VRS Hybrid	8,801.00	2,084.64	6,716.36	24%
12410	2300	Treasurer Health Ins	28,598.00	5,822.51	22,775.49	20%
12410	2400	Treasurer Life Ins	2,738.00	605.47	2,132.53	22%
12410	2510	Treasurer Dis Ins Hybrid	399.00	106.66	292.34	27%
12410	2700	Treasurer Workers Comp	184.00	160.42	23.58	87%
12410	2800	Treasurer Leave Pay	-	2,036.61	(2,036.61)	100%
12410	3000	Treasurer Pur Svcs	1,650.00	128.42	1,521.58	8%
12410	3180	Treasurer Credit Card Fees	20,000.00	-	20,000.00	0%
12410	3190	Treasurer DMV Stop	10,000.00	1,525.00	8,475.00	15%
12410	3320	Treasurer Maint Contracts	400.00	64.99	335.01	16%
12410	3500	Treasurer Printing & Binding	12,000.00	-	12,000.00	0%
12410	3600	Treasurer Advertising	500.00	-	500.00	0%
12410	5210	Treasurer Postal Svcs	27,000.00	1,612.82	25,387.18	6%
12410	5230	Treasurer Telephone	500.00	12.00	488.00	2%
12410	5500	Treasurer Travel	3,000.00	-	3,000.00	0%
12410	5510	Treasurer Local Mileage	400.00	-	400.00	0%
12410	5810	Treasurer Dues & Memb	600.00	375.00	225.00	63%
12410	6000	Treasurer Mat & Sup	4,500.00	5,527.10	(1,027.10)	123%
Total 12410 Treasurer			353,406.00	69,318.09	284,087.91	20%
12510	1100	IT Salaries	165,107.00	41,276.76	123,830.24	25%
12510	2100	IT FICA	11,678.25	2,940.32	8,737.93	25%
12510	2210	IT VRS 1&2	10,002.00	2,500.47	7,501.53	25%
12510	2220	IT VRS Hybrid	7,038.00	1,759.26	5,278.74	25%
12510	2300	IT Health Ins	20,637.00	5,159.13	15,477.87	25%
12510	2400	IT Life Ins	2,213.00	553.11	1,659.89	25%
12510	2510	IT Dis Ins Hybrid	361.00	90.00	271.00	25%
12510	2700	IT Workers Comp	148.00	129.53	18.47	88%
12510	3000	IT Pur Svcs	15,000.00	-	15,000.00	0%
12510	3320	IT Maint Contracts	1,542.00	381.00	1,161.00	25%
12510	5210	IT Postal Svcs	100.00	-	100.00	0%
12510	5230	IT Telephone	5,780.00	1,681.19	4,098.81	29%
12510	5240	IT Telecomm Online Tech	10,680.00	7,824.87	2,855.13	73%
12510	5400	IT Leases & Rentals	25,560.00	4,910.04	20,649.96	19%
12510	5500	IT Travel	1,000.00	-	1,000.00	0%
12510	5810	IT Dues & Memb	100.00	-	100.00	0%
12510	6000	IT Mat & Sup	2,000.00	-	2,000.00	0%
12510	6008	IT Vehicle Fuel	100.00	-	100.00	0%
12510	6035	IT Noncap Office Equip	1,000.00	-	1,000.00	0%
12510	6040	IT Tech SW/OL	46,314.75	21,885.28	24,429.47	47%
12510	6050	IT Noncap Technology Hardware	30,000.00	5,424.00	24,576.00	18%
Total 12510 Data Processing/IT			356,361.00	96,514.96	259,846.04	27%
13100	1300	Electoral Part Time Salaries	7,089.00	-	7,089.00	0%
13100	2100	Electoral FICA	546.00	-	546.00	0%
13100	2700	Electoral Workers Comp	6.00	6.00	-	100%
13100	3000	Electoral Pur Svcs	6,000.00	-	6,000.00	0%
13100	3160	Electoral Board Member Fees	24,330.00	160.00	24,170.00	1%
13100	3320	Electoral Maint Contracts	28,577.00	5,750.00	22,827.00	20%
13100	3500	Electoral Printing & Binding	7,110.00	2,604.61	4,505.39	37%
13100	3600	Electoral Advertising	390.00	-	390.00	0%
13100	5210	Electoral Postal Svcs	2,600.00	226.04	2,373.96	9%
13100	5400	Electoral Leases & Rentals	2,700.00	-	2,700.00	0%

Clarke County
YTD Budget Report
September 30, 2021

FUNCTION	OBJECT	ACCOUNT DESCRIPTION	REVISED BUDGET	YTD EXPENDED	AVAILABLE BUDGET	% Used
13100	5500	Electoral Travel	1,500.00	-	1,500.00	0%
13100	5510	Electoral Local Mileage	1,500.00	46.48	1,453.52	3%
13100	5810	Electoral Dues & Memb	200.00	-	200.00	0%
13100	6000	Electoral Mat & Sup	1,500.00	85.62	1,414.38	6%
Total 13100 Electoral Board and Officials			84,048.00	8,878.75	75,169.25	11%
13200	1100	Registrar Salaries	78,121.00	18,783.75	59,337.25	24%
13200	1300	Registrar Part Time Salaries	16,878.00	2,364.50	14,513.50	14%
13200	2100	Registrar FICA	5,824.00	1,623.62	4,200.38	28%
13200	2210	Registrar VRS 1&2	6,187.00	1,938.48	4,248.52	31%
13200	2300	Registrar Health Ins	7,961.00	1,990.14	5,970.86	25%
13200	2400	Registrar Life Ins	804.00	251.70	552.30	31%
13200	2700	Registrar Workers Comp	69.00	61.00	8.00	88%
13200	3000	Registrar Pur Svcs	1,400.00	54.00	1,346.00	4%
13200	3320	Registrar Maint Contracts	1,000.00	552.47	447.53	55%
13200	5210	Registrar Postal Svcs	1,840.00	417.70	1,422.30	23%
13200	5230	Registrar Telephone	1,000.00	152.07	847.93	15%
13200	5500	Registrar Travel	1,600.00	-	1,600.00	0%
13200	5510	Registrar Local Mileage	700.00	371.84	328.16	53%
13200	5810	Registrar Dues & Memb	270.00	-	270.00	0%
13200	6000	Registrar Mat & Sup	1,100.00	217.41	882.59	20%
13200	6035	Registrar Noncap Office Equip	1,700.00	-	1,700.00	0%
Total 13200 Registrar			126,454.00	28,778.68	97,675.32	23%
21100	5841	Circuit C Juror Pay	7,500.00	150.00	7,350.00	2%
21100	5842	Circuit C Jury Comm	360.00	-	360.00	0%
21100	6000	Circuit C Mat & Sup	-	163.00	(163.00)	100%
21100	7000	Circuit Ct Pyt to Joint Ops	12,000.00	-	12,000.00	0%
Total 21100 Circuit Court			19,860.00	313.00	19,547.00	2%
21200	3000	District C Pur Svcs	3,300.00	-	3,300.00	0%
21200	3150	District C Legal Svcs	270.00	-	270.00	0%
21200	3320	District C Maint Contracts	550.00	41.35	508.65	8%
21200	5210	District C Postal Svcs	700.00	145.29	554.71	21%
21200	5230	District C Telephone	2,000.00	394.70	1,605.30	20%
21200	5500	District C Travel	1,000.00	-	1,000.00	0%
21200	5810	District C Dues & Memb	200.00	-	200.00	0%
21200	6000	District C Mat & Sup	600.00	129.39	470.61	22%
Total 21200 General District Court			8,620.00	710.73	7,909.27	8%
21300	5230	Magistrate Telephone	50.00	-	50.00	0%
Total 21300 Magistrate			50.00	-	50.00	0%
21510	5600	Blue Ridge Legal Svc Contr	1,500.00	1,500.00	-	100%
Total 21510 Blue Ridge Legal Services			1,500.00	1,500.00	-	100%
21600	3000	J&D Court Pur Svcs	3,000.00	-	3,000.00	0%
21600	3320	J&D Court Maint Contracts	700.00	323.73	376.27	46%
21600	5210	J&D Court Postal Svcs	700.00	-	700.00	0%
21600	5230	J&D Court Telephone	700.00	165.76	534.24	24%
21600	5500	J&D Court Travel	500.00	-	500.00	0%
21600	5810	J&D Court Dues & Memb	50.00	50.00	-	100%
21600	6000	J&D Court Mat & Sup	750.00	-	750.00	0%
Total 21600 Juvenile & Domestic Relations			6,400.00	539.49	5,860.51	8%
21700	1100	Clk of CC Salaries	183,998.00	45,999.24	137,998.76	25%
21700	2100	Clk of CC FICA	14,025.00	3,510.77	10,514.23	25%
21700	2210	Clk of CC VRS 1&2	11,293.00	2,823.18	8,469.82	25%
21700	2220	Clk of CC VRS Hybrid	7,910.00	1,923.96	5,986.04	24%
21700	2300	Clk of CC Health Ins	7,961.00	1,990.14	5,970.86	25%
21700	2400	Clk of CC Life Ins	2,467.00	616.38	1,850.62	25%
21700	2510	Clk of CC Dis Ins Hybrid	395.00	98.43	296.57	25%
21700	2700	Clk of CC Workers Comp	164.00	143.48	20.52	87%
21700	3000	Clk of CC Pur Svcs	2,500.00	-	2,500.00	0%
21700	3320	Clk of CC Maint Contracts	18,000.00	121.15	17,878.85	1%
21700	3500	Clk of CC Printing & Binding	1,000.00	-	1,000.00	0%
21700	3510	Clk of CC Microfilming	7,000.00	1,226.73	5,773.27	18%
21700	5210	Clk of CC Postal Svcs	5,700.00	2,000.00	3,700.00	35%
21700	5230	Clk of CC Telephone	1,025.00	255.67	769.33	25%
21700	5810	Clk of CC Dues & Memb	400.00	370.00	30.00	93%

**Clarke County
YTD Budget Report
September 30, 2021**

FUNCTION	OBJECT	ACCOUNT DESCRIPTION	REVISED BUDGET	YTD EXPENDED	AVAILABLE BUDGET	% Used
21700	6000	Clk of CC Mat & Sup	6,500.00	706.82	5,793.18	11%
Total 21700 Clerk of the Circuit Court			270,338.00	61,785.95	208,552.05	23%
21910	1100	VictimWit Regular Salary	45,096.00	11,162.88	33,933.12	25%
21910	1300	VictimWit Part Time Sal	14,815.00	3,852.00	10,963.00	26%
21910	2100	VictimWit FICA	4,583.19	1,150.92	3,432.27	25%
21910	2210	VictimWit VRS 1&2	4,653.91	1,152.00	3,501.91	25%
21910	2400	VictimWit Life Ins	604.29	149.58	454.71	25%
21910	2700	VictimWit Workers Comp	43.61	47.00	(3.39)	108%
21910	5210	VictimWit Postal Svcs	220.00	-	220.00	0%
21910	5230	VictimWit Telephone	589.00	124.98	464.02	21%
21910	5500	VictimWit Travel	831.00	307.56	523.44	37%
21910	5510	VictimWit Travel Local Mileage	42.00	-	42.00	0%
21910	5810	VictimWit Dues & Memb	150.00	-	150.00	0%
21910	6000	VictimWit Mat & Sup	563.00	-	563.00	0%
Total 21910 Victim and Witness Assistance			72,191.00	17,946.92	54,244.08	25%
21940	5600	Regional Crt Svc Entity Gift	6,930.00	-	6,930.00	0%
Total 21940 Regional Court Services			6,930.00	-	6,930.00	0%
22100	1100	Comm Atty Salaries	245,805.00	69,422.13	176,382.87	28%
22100	1100	Comm Atty VSTOP Salaries	26,665.00	6,666.48	19,998.52	25%
22100	1300	Comm Atty Part Time Salaries	53,464.00	4,200.00	49,264.00	8%
22100	2100	Comm Atty FICA	23,413.00	5,363.03	18,049.97	23%
22100	2100	Comm Atty VSTOP FICA	550.00	510.36	39.64	93%
22100	2210	Comm Atty VRS 1&2	13,311.00	3,257.01	10,053.99	24%
22100	2210	Comm Atty VSTOP VRS 1&2	742.00	210.36	531.64	28%
22100	2220	Comm Atty VRS Hybrid	17,325.00	3,555.60	13,769.40	21%
22100	2300	Comm Atty Health Ins	20,637.00	5,159.13	15,477.87	25%
22100	2400	Comm Atty Life Ins	3,539.00	884.58	2,654.42	25%
22100	2400	Comm Atty VSTOP Life Ins	96.00	27.30	68.70	28%
22100	2510	Comm Atty Dis Ins Hybrid	728.00	181.92	546.08	25%
22100	2700	Comm Atty Workers Comp	284.00	263.07	20.93	93%
22100	3320	Comm Atty Maint Contracts	500.00	187.20	312.80	37%
22100	5210	Comm Atty Postal Svcs	1,300.00	400.00	900.00	31%
22100	5230	Comm Atty Telephone	3,000.00	549.12	2,450.88	18%
22100	5500	Comm Atty Travel	6,500.00	1,680.19	4,819.81	26%
22100	5549	Comm Atty Witness Travel Expen	1,500.00	-	1,500.00	0%
22100	5810	Comm Atty Dues & Memb	2,500.00	1,627.32	872.68	65%
22100	6000	Comm Atty Mat & Sup	3,000.00	672.28	2,327.72	22%
22100	6035	Comm Atty Noncap Office Equip	400.00	-	400.00	0%
Total 22100 Commonwealth's Attorney			425,259.00	104,817.08	320,441.92	25%
31200	1100	Sheriff Salaries	1,571,671.00	384,264.07	1,187,406.93	24%
31200	1200	Sheriff Overtime	33,500.00	12,803.50	20,696.50	38%
31200	1200	CITAC Overtime	5,000.00	227.17	4,772.83	5%
31200	1200	DMV Alcohol Grant Overtime	8,941.00	2,335.13	6,605.87	26%
31200	1200	DMV Speed Overtime	4,645.00	937.47	3,707.53	20%
31200	1300	Sheriff Part Time Salaries	43,860.00	11,478.57	32,381.43	26%
31200	1660	Sheriff Emp Bonuses	-	500.00	(500.00)	100%
31200	2100	Sheriff FICA	126,659.00	35,548.01	91,110.99	28%
31200	2100	CITAC FICA	383.00	17.19	365.81	4%
31200	2100	DMV Alcohol Grant FICA	684.00	164.17	519.83	24%
31200	2100	DMV Speed FICA	356.00	64.03	291.97	18%
31200	2210	Sheriff VRS 1&2	133,293.00	29,819.49	103,473.51	22%
31200	2220	Sheriff VRS Hybrid	30,735.00	9,194.37	21,540.63	30%
31200	2300	Sheriff Health Ins	209,501.00	50,552.07	158,948.93	24%
31200	2300	Sheriff CITAC Health Ins	-	28.44	(28.44)	100%
31200	2300	DMV Alcohol Grant Health Ins	-	266.88	(266.88)	100%
31200	2300	DMV Speed Health Ins	-	118.94	(118.94)	100%
31200	2400	Sheriff Life Ins	21,075.00	5,065.80	16,009.20	24%
31200	2510	Sheriff Dis Ins Hybrid	1,483.00	470.37	1,012.63	32%
31200	2700	Sheriff Workers Comp	29,057.00	28,546.98	510.02	98%
31200	2800	Sheriff Leave Pay	63,995.00	68,907.66	(4,912.66)	108%
31200	2860	Sheriff LODA	25,660.00	24,641.59	1,018.41	96%
31200	3000	Sheriff Pur Svcs	30,000.00	4,799.70	25,200.30	16%
31200	3320	Sheriff Maint Contracts	157,993.00	34,894.07	123,098.93	22%

Clarke County
YTD Budget Report
September 30, 2021

FUNCTION	OBJECT	ACCOUNT DESCRIPTION	REVISED BUDGET	YTD EXPENDED	AVAILABLE BUDGET	% Used
31200	3320	Sheriff E-Ticket Maint Svc	-	4,950.00	(4,950.00)	100%
31200	3350	Sheriff Insured Repair Svcs	2,000.00	-	2,000.00	0%
31200	3500	Sheriff Printing & Binding	1,000.00	-	1,000.00	0%
31200	5210	Sheriff Postal Svcs	2,200.00	258.44	1,941.56	12%
31200	5230	Sheriff Telephone	65,000.00	15,281.38	49,718.62	24%
31200	5300	Sheriff Insurance	15,000.00	10,673.39	4,326.61	71%
31200	5400	Sheriff Leases & Rentals	17,000.00	7,141.50	9,858.50	42%
31200	5500	Sheriff Travel	61,600.00	-	61,600.00	0%
31200	5500	Sheriff Travel - Communication	-	2,230.24	(2,230.24)	100%
31200	5500	Sheriff Travel - Sworn Staff	-	6,389.83	(6,389.83)	100%
31200	5800	Sheriff Miscellaneous Expendit	1,000.00	15.00	985.00	2%
31200	5810	Sheriff Dues & Memb	5,000.00	514.95	4,485.05	10%
31200	6000	Sheriff Mat & Sup	57,000.00	164.63	56,835.37	0%
31200	6000	Sheriff COS Mat & Sup	-	418.38	(418.38)	100%
31200	6000	Sheriff ETK Mat & Sup	25,000.00	-	25,000.00	0%
31200	6000	Sheriff PSU Mat & Sup	-	1,050.00	(1,050.00)	100%
31200	6000	Sheriff SOS Mat & Sup	-	2,133.39	(2,133.39)	100%
31200	6000	Sheriff VRP Mat & Sup	-	4,654.49	(4,654.49)	100%
31200	6000	ICAC Mat & Sup	5,000.00	-	5,000.00	0%
31200	6000	BVP Vest grant Mat & Sup	1,400.00	-	1,400.00	0%
31200	6008	Sheriff Vehicle Fuel	60,000.00	12,661.83	47,338.17	21%
31200	6011	Sheriff Clothing	15,000.00	-	15,000.00	0%
31200	6011	Sheriff Uniform Sworn Staff	-	2,782.62	(2,782.62)	100%
31200	6015	Sheriff Ammunition	28,000.00	1,548.67	26,451.33	6%
Total 31200 Sheriff - Total			2,859,691.00	778,514.41	2,081,176.59	27%
31210	5600	Criminal Justice Training Ctr	19,593.00	19,422.00	171.00	99%
Total 31210 Criminal Justice Training Ctr			19,593.00	19,422.00	171.00	99%
31220	5600	Drug Task Force Entity Gift	12,500.00	-	12,500.00	0%
Total 31220 Drug Task Force			12,500.00	-	12,500.00	0%
32200	2510	Vol Fire Dis Ins Hybrid	11,000.00	-	11,000.00	0%
32200	2700	Vol Fire Worker's Comp	21,000.00	-	21,000.00	0%
32200	3000	Vol Fire Pur Svcs	38,000.00	2,310.62	35,689.38	6%
32200	5300	Vol Fire Co Insurance	41,000.00	11,934.57	29,065.43	29%
32200	5600	Vol Fire Companies Entity Gift	25,000.00	-	25,000.00	0%
32200	5697	Vol Fire 4 for Life	19,000.00	6,077.01	12,922.99	32%
32200	5698	Vol Fire Fire Programs	34,500.00	6,442.29	28,057.71	19%
32200	6000	Vol Fire&Res Mat'l Suppls	2,000.00	-	2,000.00	0%
Total 32200 Volunteer Fire Companies			191,500.00	26,764.49	164,735.51	14%
32201	2860	Blue Ridge Vol Fire Co LODA	1,650.00	1,309.10	340.90	79%
32201	5510	Blue Ridge Vol Fire Fee for Svc	13,800.00	-	13,800.00	0%
32201	5600	Blue Ridge Vol Fire Co Contrib	65,000.00	16,250.00	48,750.00	25%
Total 32201 Blue Ridge Volunteer Fire Co			80,450.00	17,559.10	62,890.90	22%
32202	2860	Boyce Volunteer Fire Co LODA	1,800.00	1,611.20	188.80	90%
32202	5510	Boyce Vol Fire Co Fee for Svc	28,750.00	-	28,750.00	0%
32202	5600	Boyce Volunteer Fire Co Contr	90,000.00	-	90,000.00	0%
Total 32202 Boyce Volunteer Fire Co			120,550.00	1,611.20	118,938.80	1%
32203	2860	Enders Volunteer Fire Co LODA	3,350.00	3,222.40	127.60	96%
32203	5510	Enders Vol Fire Co Fee for Svc	72,450.00	-	72,450.00	0%
32203	5600	Enders Volunteer Fire Co Contr	90,000.00	45,000.00	45,000.00	50%
Total 32203 Enders Volunteer Fire Co			165,800.00	48,222.40	117,577.60	29%
32310	1100	EMS Salaries	654,973.00	142,443.04	512,529.96	22%
32310	1100	SAFER Grant Salaries	193,051.00	48,726.68	144,324.32	25%
32310	1200	EMS Overtime	77,200.00	32,856.51	44,343.49	43%
32310	1300	EMS Part Time Salaries	150,400.00	25,936.88	124,463.12	17%
32310	1660	EMS Employee Bonuses	-	400.00	(400.00)	100%
32310	1660	SAFER Grant Employee Bonus	-	8,000.00	(8,000.00)	100%
32310	2100	EMS FICA	63,877.00	15,475.84	48,401.16	24%
32310	2100	SAFER Grant FICA	14,102.00	4,109.40	9,992.60	29%
32310	2210	EMS VRS 1&2	62,517.00	13,293.88	49,223.12	21%
32310	2210	SAFER Grant VRS 1&2	19,926.00	5,028.64	14,897.36	25%
32310	2220	EMS VRS Hybrid	5,324.00	1,269.27	4,054.73	24%
32310	2300	EMS Health Ins	96,609.00	23,164.16	73,444.84	24%
32310	2300	SAFER Grant Health Ins	30,400.00	7,462.16	22,937.84	25%

Clarke County
YTD Budget Report
September 30, 2021

FUNCTION	OBJECT	ACCOUNT DESCRIPTION	REVISED BUDGET	YTD EXPENDED	AVAILABLE BUDGET	% Used
32310	2400	EMS Life Ins	8,783.00	1,890.99	6,892.01	22%
32310	2400	SAFER Grant Group Life Ins	2,588.00	652.90	1,935.10	25%
32310	2510	EMS Dis Ins Hybrid	260.00	64.95	195.05	25%
32310	2700	EMS Workers Comp	54,405.00	35,758.51	18,646.49	66%
32310	2800	EMS Annual Leave Payouts	8,500.00	13,037.00	(4,537.00)	153%
32310	2860	EMS LODA	14,000.00	17,797.00	(3,797.00)	127%
32310	3000	EMS Pur Svcs	69,100.00	11,641.45	57,458.55	17%
32310	5210	EMS Postal Services	200.00	12.39	187.61	6%
32310	5230	EMS Telephone	1,550.00	145.50	1,404.50	9%
32310	5230	EMS LEMPG Grant-Telephone	-	1,616.94	(1,616.94)	100%
32310	5500	EMS Travel	6,000.00	1,621.38	4,378.62	27%
32310	5800	EMS Miscellaneous	14,500.00	4,372.63	10,127.37	30%
32310	6000	EMS Mat & Sup	40,000.00	10,234.42	29,765.58	26%
32310	6000	EMS LEMPG Grant Mat & Sup	7,500.00	-	7,500.00	0%
32310	6008	EMS Vehicle Fuel	20,000.00	4,609.07	15,390.93	23%
32310	6011	EMS Clothing	15,000.00	1,929.20	13,070.80	13%
32310	6035	EMS Noncap Office Equip	2,000.00	-	2,000.00	0%
32310	6040	EMS Tech SW/OL	15,000.00	561.00	14,439.00	4%
32310	8200	EMS Capital Outlay Adds	10,500.00	6,500.25	3,999.75	62%
Total 32310 Fire and Rescue Services			1,658,265.00	440,612.04	1,217,652.96	27%
32320	5600	Lord Fairfax EMS Contribution	6,575.00	6,575.00	-	100%
Total 32320 Lord Fairfax Emergency Medical			6,575.00	6,575.00	-	100%
32400	5600	Forestry Svcs Entity Gift	2,874.00	-	2,874.00	0%
Total 32400 Forestry Services			2,874.00	-	2,874.00	0%
33210	7000	Regional Jail Joint Ops	520,285.00	254,989.00	265,296.00	49%
Total 33210 Regional Jail			520,285.00	254,989.00	265,296.00	49%
33220	3840	Juv Det Ctr Intergov Svc Agree	36,168.00	-	36,168.00	0%
Total 33220 Juvenile Detention Center			36,168.00	-	36,168.00	0%
33300	5230	Probation Telephone	100.00	12.00	88.00	12%
33300	6000	Probation Mat & Sup	300.00	-	300.00	0%
Total 33300 Probation Office			400.00	12.00	388.00	3%
34100	1100	Bldg Insp Salaries	155,179.00	38,097.24	117,081.76	25%
34100	1300	Bldg Insp Part Time Salaries	22,390.00	5,607.00	16,783.00	25%
34100	2100	Bldg Insp FICA	12,262.00	3,129.53	9,132.47	26%
34100	2210	Bldg Insp VRS 1&2	7,156.00	1,788.78	5,367.22	25%
34100	2220	Bldg Insp VRS Hybrid	9,065.00	1,257.45	7,807.55	14%
34100	2300	Bldg Insp Health Ins	27,587.00	6,753.20	20,833.80	24%
34100	2400	Bldg Insp Life Ins	2,081.00	510.48	1,570.52	25%
34100	2510	Bldg Insp Dis Ins Hybrid	454.00	109.62	344.38	24%
34100	2700	Bldg Insp Workers Comp	3,585.00	2,236.43	1,348.57	62%
34100	2800	Bldg Insp Leave Pay	-	60.05	(60.05)	100%
34100	3000	Bldg Insp Pur Svcs	600.00	-	600.00	0%
34100	3320	Bldg Insp Maint Contracts	500.00	403.79	96.21	81%
34100	5210	Bldg Insp Postal Svcs	50.00	18.11	31.89	36%
34100	5230	Bldg Insp Telephone	2,500.00	793.32	1,706.68	32%
34100	5500	Bldg Insp Travel	2,500.00	-	2,500.00	0%
34100	5810	Bldg Insp Dues & Memb	1,000.00	-	1,000.00	0%
34100	6000	Bldg Insp Mat & Sup	2,000.00	174.35	1,825.65	9%
34100	6008	Bldg Insp Vehicle Fuel	2,500.00	551.19	1,948.81	22%
Total 34100 Building Inspections			251,409.00	61,490.54	189,918.46	24%
35100	1100	AnimalCtrl Salaries	80,057.00	13,651.74	66,405.26	17%
35100	1300	AnimalCtrl Part Time Salaries	14,000.00	5,116.36	8,883.64	37%
35100	2100	AnimalCtrl FICA	6,486.00	1,455.39	5,030.61	22%
35100	2210	AnimalCtrl VRS 1&2	4,892.00	-	4,892.00	0%
35100	2220	AnimalCtrl VRS Hybrid	3,535.00	1,408.86	2,126.14	40%
35100	2300	AnimalCtrl Health Ins	8,688.00	-	8,688.00	0%
35100	2400	AnimalCtrl Life Ins	1,074.00	182.94	891.06	17%
35100	2510	AnimalCtrl Dis Ins Hybrid	173.00	72.09	100.91	42%
35100	2700	AnimalCtrl Workers Comp	1,297.00	1,024.00	273.00	79%
35100	2800	AnimalCtrl Leave Pay	-	404.80	(404.80)	100%
35100	3000	AnimalCtrl Pur Svcs	8,500.00	1,212.52	7,287.48	14%
35100	3320	AnimalCtrl Maint Svc Contracts	150.00	15.38	134.62	10%
35100	3500	AnimalCtrl Printing & Binding	200.00	-	200.00	0%

Clarke County
YTD Budget Report
September 30, 2021

FUNCTION	OBJECT	ACCOUNT DESCRIPTION	REVISED BUDGET	YTD EXPENDED	AVAILABLE BUDGET	% Used
35100	5230	AnimalCtrl Telephone	700.00	133.78	566.22	19%
35100	5400	Anml Shelter Leases and Rental	-	1.00	(1.00)	100%
35100	5500	AnimalCtrl Travel	500.00	-	500.00	0%
35100	5510	AnimalCtrl Local Mileage	100.00	-	100.00	0%
35100	6000	AnimalCtrl Mat & Sup	7,500.00	2,827.62	4,672.38	38%
35100	6008	AnimalCtrl Vehicle Fuel	1,500.00	255.53	1,244.47	17%
35100	6011	AnimalCtrl Clothing	500.00	-	500.00	0%
Total 35100 Animal Control			139,852.00	27,762.01	112,089.99	20%
35300	3000	Exam&Bury Pur Svcs	200.00	20.00	180.00	10%
Total 35300 Med Examiner & Indigent Burial			200.00	20.00	180.00	10%
42400	3840	RefuseDisp Intergov Svc Agreem	180,000.00	36,111.07	143,888.93	20%
Total 42400 Refuse Disposal			180,000.00	36,111.07	143,888.93	20%
42410	1300	SWC PT Salaries - Regular	21,303.00	3,734.50	17,568.50	18%
42410	2100	SWC FICA	1,630.00	285.68	1,344.32	18%
42410	2700	Worker's Compensation	775.00	422.47	352.53	55%
42410	3000	SWC Pur Svcs	45,000.00	12,859.91	32,140.09	29%
42410	5110	SWC Electrical Services	2,000.00	240.31	1,759.69	12%
42410	5230	SWC Telephone	1,000.00	125.58	874.42	13%
42410	6000	SWC Mat & Sup	1,000.00	50.46	949.54	5%
Total 42410 Solid Waste Convenience			72,708.00	17,718.91	54,989.09	24%
42600	3000	LitterCtrl Pur Svcs	4,000.00	368.95	3,631.05	9%
Total 42600 Litter Control			4,000.00	368.95	3,631.05	9%
42700	3840	Sanitation Intergov Svc Agreem	37,000.00	5,232.98	31,767.02	14%
42700	5600	Sanitation Entity Gift	207,000.00	-	207,000.00	0%
Total 42700 Sanitation			244,000.00	5,232.98	238,767.02	2%
43200	1100	Maintenanc Salaries	161,761.00	46,818.95	114,942.05	29%
43200	2100	Maintenanc FICA	11,870.00	3,343.16	8,526.84	28%
43200	2210	Maintenanc VRS 1&2	9,571.00	2,802.96	6,768.04	29%
43200	2220	Maintenanc VRS Hybrid	7,511.00	2,106.59	5,404.41	28%
43200	2300	Maintenanc Health Ins	18,938.00	6,357.95	12,580.05	34%
43200	2400	Maintenanc Life Ins	2,168.00	637.48	1,530.52	29%
43200	2510	Maintenanc Dis Ins Hybrid	314.00	107.78	206.22	34%
43200	2700	Maintenanc Workers Comp	2,103.00	1,609.36	493.64	77%
43200	2750	Maintenanc RHCC	137.00	-	137.00	0%
43200	3000	Maintenanc Pur Svcs	38,000.00	14,352.04	23,647.96	38%
43200	3000	JGC Maintenanc Pur Svcs	20,000.00	2,257.80	17,742.20	11%
43200	3000	RT Maintenanc Pur Svcs	7,500.00	1,645.72	5,854.28	22%
43200	3000	ChurchSt Maint Pur Svcs	2,000.00	120.00	1,880.00	6%
43200	3000	104Church Maint Pur Svcs	16,000.00	992.49	15,007.51	6%
43200	3000	225Rams Maint Pur Svcs	7,500.00	287.00	7,213.00	4%
43200	3000	524West Maint Pur Svcs	1,000.00	7.00	993.00	1%
43200	3000	AIRec Maint Pur Svcs	14,500.00	697.50	13,802.50	5%
43200	3000	AIOff Maint Pur Svcs	15,000.00	630.00	14,370.00	4%
43200	3000	AIPool Maint Pur Svcs	5,000.00	14.00	4,986.00	0%
43200	3000	AIBase Maint Pur Svcs	750.00	-	750.00	0%
43200	3000	AI Soc Maint Pur Svcs	1,300.00	-	1,300.00	0%
43200	3000	106Church Maint Pur Svcs	1,000.00	3.50	996.50	0%
43200	3000	36EMain Maint Pur Svcs	500.00	-	500.00	0%
43200	3000	311EMain Maint Pur Svcs	3,000.00	273.00	2,727.00	9%
43200	3000	309WMain Maint Pur Svcs	2,000.00	7.00	1,993.00	0%
43200	3000	129Rams Maint Pur Svcs	1,000.00	1,564.75	(564.75)	156%
43200	3320	Maintenanc Maint Contracts	41,000.00	2,720.88	38,279.12	7%
43200	3320	JGC Maint Contracts	4,500.00	3,048.68	1,451.32	68%
43200	3320	RT Maintenanc Maint Contracts	4,500.00	4,457.45	42.55	99%
43200	3320	ChurchSt Maint Contracts	3,500.00	3,064.84	435.16	88%
43200	3320	104Church Maint Contracts	3,800.00	3,508.50	291.50	92%
43200	3320	225Rams Maint Contracts	3,000.00	2,649.66	350.34	88%
43200	3320	524West Maint Contracts	742.00	-	742.00	0%
43200	3320	AIRec Maint Contracts	3,700.00	1,565.15	2,134.85	42%
43200	3320	106Church Maint Contracts	450.00	246.48	203.52	55%
43200	3320	36EMain Maint Contracts	450.00	443.66	6.34	99%
43200	3320	311EMain Maint Contracts	4,000.00	2,855.33	1,144.67	71%
43200	3320	309WMain Maint Serv Contracts	750.00	-	750.00	0%

**Clarke County
YTD Budget Report
September 30, 2021**

FUNCTION	OBJECT	ACCOUNT DESCRIPTION	REVISED BUDGET	YTD EXPENDED	AVAILABLE BUDGET	% Used
43200	3320	129Rams Maint Contracts	750.00	252.64	497.36	34%
43200	3340	Maintenanc Custodial Contracts	55,000.00	13,590.21	41,409.79	25%
43200	3340	JGC Maintenanc Custodial Contr	25,000.00	3,563.25	21,436.75	14%
43200	3340	311EMain Maint Cus Contracts	3,600.00	1,383.75	2,216.25	38%
43200	3340	Cooley MaintCustodial Contrcts	-	324.00	(324.00)	100%
43200	3600	Maintenanc Advertising	1,200.00	-	1,200.00	0%
43200	5110	JGC Maintenanc Electric	40,000.00	5,043.39	34,956.61	13%
43200	5110	RT Maintenanc Electric	12,100.00	2,243.03	9,856.97	19%
43200	5110	ChurchSt Maint Electric	30,000.00	3,410.29	26,589.71	11%
43200	5110	104Church Maint Electric	12,000.00	1,777.72	10,222.28	15%
43200	5110	225Rams Maint Electric	7,500.00	1,851.74	5,648.26	25%
43200	5110	524West Maint Electric	2,200.00	344.46	1,855.54	16%
43200	5110	AlRec Maint Electric	31,000.00	4,905.90	26,094.10	16%
43200	5110	AlOff Maint Electric	5,000.00	973.43	4,026.57	19%
43200	5110	AlPool Maint Electric	8,000.00	3,234.60	4,765.40	40%
43200	5110	AlBase Maint Electric	840.00	47.33	792.67	6%
43200	5110	AlSoc Maint Electric	500.00	169.63	330.37	34%
43200	5110	311EMain Maint Electric	9,000.00	1,218.32	7,781.68	14%
43200	5110	309WMain Maint Electrical Svcs	2,000.00	141.30	1,858.70	7%
43200	5110	129Rams Maint Electric	3,000.00	514.21	2,485.79	17%
43200	5120	JGC Maintenanc Heating	5,500.00	124.33	5,375.67	2%
43200	5120	RT Maintenanc Heating	1,600.00	68.24	1,531.76	4%
43200	5120	104Church Maint Heating	3,800.00	89.69	3,710.31	2%
43200	5120	225Rams Maint Heating	6,000.00	-	6,000.00	0%
43200	5120	524West Maint Heating	3,000.00	-	3,000.00	0%
43200	5120	AlRec Maint Heating	5,000.00	419.51	4,580.49	8%
43200	5120	309WMain Maint Heating	2,000.00	-	2,000.00	0%
43200	5120	129Rams Maint Heating	3,000.00	-	3,000.00	0%
43200	5130	Maintenanc Water & Sewer	750.00	91.50	658.50	12%
43200	5130	JGC Maintenanc Water & Sewer	1,500.00	189.09	1,310.91	13%
43200	5130	RT Maintenanc Water & Sewer	4,500.00	1,079.59	3,420.41	24%
43200	5130	104Church Maint Water & Sewer	750.00	98.21	651.79	13%
43200	5130	225Rams Maint Water & Sewer	500.00	15.00	485.00	3%
43200	5130	AlRec Maint Water & Sewer	2,000.00	134.30	1,865.70	7%
43200	5130	AlOff Maint Water & Sewer	3,000.00	599.17	2,400.83	20%
43200	5130	AlPool Maint Water & Sewer	20,000.00	4,617.15	15,382.85	23%
43200	5130	311EMain Maint Water & Sewer	1,200.00	171.00	1,029.00	14%
43200	5130	309WMain Maint Water & Sewer	1,000.00	235.31	764.69	24%
43200	5130	129Rams Maint Water & Sewer	600.00	34.78	565.22	6%
43200	5230	Maintenanc Telephone	2,000.00	295.38	1,704.62	15%
43200	5300	Maintenanc Insurance	43,000.00	43,036.96	(36.96)	100%
43200	5400	Maintenanc Leases & Rentals	1,000.00	-	1,000.00	0%
43200	5500	Maintenanc Travel	750.00	-	750.00	0%
43200	6000	Maintenanc Mat & Sup	35,000.00	5,059.84	29,940.16	14%
43200	6000	JGC Maintenance Mat & Sup	2,000.00	853.99	1,146.01	43%
43200	6000	RT Maint Mat & Sup	1,500.00	125.00	1,375.00	8%
43200	6000	ChurchSt Maint Mat & Sup	1,000.00	175.55	824.45	18%
43200	6000	104Church Maint Mat & Sup	1,500.00	11.94	1,488.06	1%
43200	6000	225Rams Maint Mat & Sup	1,000.00	184.19	815.81	18%
43200	6000	524West Maint Mat & Sup	750.00	-	750.00	0%
43200	6000	AlRec Maint Mat & Sup	2,200.00	137.06	2,062.94	6%
43200	6000	AlOff Maint Mat & Sup	6,000.00	2,599.57	3,400.43	43%
43200	6000	AlPool Maint Mat & Sup	5,000.00	114.30	4,885.70	2%
43200	6000	AlBase Maint Mat & Sup	5,000.00	592.50	4,407.50	12%
43200	6000	AlSoc Maint Mat & Sup	8,500.00	3,085.04	5,414.96	36%
43200	6000	106Church Maint Mat & Sup	500.00	-	500.00	0%
43200	6000	32EMain Maint Mat & Sup	500.00	-	500.00	0%
43200	6000	36EMain Maint Mat & Sup	500.00	45.99	454.01	9%
43200	6000	311EMain Maint Mat & Sup	1,000.00	-	1,000.00	0%
43200	6000	309WMain Maint Mat & Sup	500.00	-	500.00	0%
43200	6000	129Rams Maint Mat & Sup	500.00	-	500.00	0%
43200	6008	Maintenanc Vehicle Fuel	5,000.00	1,233.31	3,766.69	25%
Total 43200 General Property Maintenance - All Accounts			859,905.00	221,703.35	638,201.65	26%

Clarke County
YTD Budget Report
September 30, 2021

FUNCTION	OBJECT	ACCOUNT DESCRIPTION	REVISED BUDGET	YTD EXPENDED	AVAILABLE BUDGET	% Used
51100	5600	Local Health Dept Contribution	193,642.00	96,821.00	96,821.00	50%
Total 51100 Local Health Department			193,642.00	96,821.00	96,821.00	50%
51200	5600	Our Health Entity Gift	6,500.00	1,625.00	4,875.00	25%
Total 51200 Our Health			6,500.00	1,625.00	4,875.00	25%
52400	5600	N Shen Vally Sub Abuse Coal Co	15,000.00	3,750.00	11,250.00	25%
Total 52400 N Shen Valley Subst Abuse Coal			15,000.00	3,750.00	11,250.00	25%
52500	5600	NW Community Svc Entity Gift	96,350.00	24,087.50	72,262.50	25%
Total 52500 Northwestern Community Svcs			96,350.00	24,087.50	72,262.50	25%
52800	5600	Concern Hotline Entity Gift	1,500.00	-	1,500.00	0%
Total 52800 Concern Hotline			1,500.00	-	1,500.00	0%
53230	5600	SAAA EntityGift	40,000.00	10,000.00	30,000.00	25%
Total 53230 Shenandoah Area Agency on Aging			40,000.00	10,000.00	30,000.00	25%
53240	5600	Virginia Regional Transit Cont	19,302.00	4,825.50	14,476.50	25%
Total 53240 VA Regional Transp Assn			19,302.00	4,825.50	14,476.50	25%
53250	5600	FISH of Clarke County Contr	1,000.00	-	1,000.00	0%
Total 53250 FISH of Clarke County			1,000.00	-	1,000.00	0%
53600	5600	Access Independence Contr	1,000.00	-	1,000.00	0%
Total 53600 Access Independence			1,000.00	-	1,000.00	0%
53700	5600	Laurel Center Contribution	4,000.00	-	4,000.00	0%
Total 53700 The Laurel Ctr (Women's Shltr)			4,000.00	-	4,000.00	0%
53710	5600	Tax Relief for the Elderly	215,000.00	-	215,000.00	0%
Total 53710 Tax Relief for the Elde			215,000.00	-	215,000.00	0%
69100	5600	Lord FairfaxComm College Cont	17,965.00	4,491.25	13,473.75	25%
Total 69100 Lord Fairfax Community College			17,965.00	4,491.25	13,473.75	25%
71100	1100	Parks Adm Salaries	327,535.00	81,883.71	245,651.29	25%
71100	1300	Parks Adm Part Time Salaries	21,919.00	6,700.50	15,218.50	31%
71100	2100	Parks Adm FICA	25,410.00	6,216.05	19,193.95	24%
71100	2210	Parks Adm VRS 1&2	33,804.00	8,450.40	25,353.60	25%
71100	2300	Parks Adm Health Ins	52,481.00	13,119.69	39,361.31	25%
71100	2400	Parks Adm Life Ins	4,392.00	1,097.22	3,294.78	25%
71100	2700	Parks Adm Workers Comp	9,077.00	6,814.41	2,262.59	75%
71100	3000	Parks Adm Pur Svcs	570.00	111.16	458.84	20%
71100	3180	Parks Adm Credit Card Fees	8,000.00	-	8,000.00	0%
71100	3320	Parks Adm Maint Contracts	3,000.00	654.36	2,345.64	22%
71100	3500	Parks Adm Printing & Binding	395.00	50.00	345.00	13%
71100	3600	Parks Adm Advertising	1,175.00	-	1,175.00	0%
71100	5210	Parks Adm Postal Svcs	1,762.00	-	1,762.00	0%
71100	5230	Parks Adm Telephone	1,000.00	206.50	793.50	21%
71100	5400	Parks Adm Leases & Rentals	515.00	121.58	393.42	24%
71100	5500	Parks Adm Travel	2,190.00	-	2,190.00	0%
71100	5810	Parks Adm Dues & Memb	1,879.00	1,081.00	798.00	58%
71100	6000	Parks Adm Mat & Sup	5,156.00	858.20	4,297.80	17%
71100	6008	Parks Adm Vehicle Fuel	700.00	141.09	558.91	20%
71100	6011	Parks Adm Clothing	1,100.00	-	1,100.00	0%
Total 71100 Parks Administration			502,060.00	127,505.87	374,554.13	25%
71310	1100	Rec Center Salaries	55,784.00	13,946.01	41,837.99	25%
71310	1300	Rec Center Part Time Salaries	39,537.00	3,896.66	35,640.34	10%
71310	2100	Rec Center FICA	7,239.00	1,353.44	5,885.56	19%
71310	2210	Rec Center VRS 1&2	5,757.00	1,439.22	4,317.78	25%
71310	2300	Rec Center Health Ins	7,961.00	1,990.14	5,970.86	25%
71310	2400	Rec Center Life Ins	748.00	186.87	561.13	25%
71310	2700	Rec Center Workers Comp	2,476.00	1,859.29	616.71	75%
71310	3600	Rec Center Advertising	890.00	-	890.00	0%
71310	5830	Rec Center Refunds	1,000.00	80.00	920.00	8%
71310	6000	Rec Center Mat & Sup	7,595.00	472.04	7,122.96	6%
71310	6012	Rec Center Merch for Resale	3,000.00	391.22	2,608.78	13%
Total 71310 Recreation Center			131,987.00	25,614.89	106,372.11	19%
71320	1200	Pool Overtime	-	109.12	(109.12)	100%
71320	1300	Pool Part Time Salaries	67,277.00	47,858.43	19,418.57	71%
71320	2100	Pool FICA	5,147.00	3,660.21	1,486.79	71%
71320	2300	Pool Health Ins	-	796.64	(796.64)	100%
71320	2700	Pool Workers Comp	1,747.00	1,408.92	338.08	81%
71320	3000	Pool Pur Svcs	1,500.00	1,452.75	47.25	97%

**Clarke County
YTD Budget Report
September 30, 2021**

FUNCTION	OBJECT	ACCOUNT DESCRIPTION	REVISED BUDGET	YTD EXPENDED	AVAILABLE BUDGET	% Used
71320	5500	Pool Travel	275.00	-	275.00	0%
71320	5810	Pool Dues & Memb	1,800.00	-	1,800.00	0%
71320	5830	Pool Refunds	1,160.00	1,190.50	(30.50)	103%
71320	6000	Pool Mat & Sup	2,700.00	435.98	2,264.02	16%
71320	6011	Pool Clothing	1,746.00	-	1,746.00	0%
71320	6012	Pool Merch for Resale	680.00	-	680.00	0%
71320	6026	Pool Chemicals	10,000.00	497.27	9,502.73	5%
Total 71320 Swimming Pool			94,032.00	57,409.82	36,622.18	61%
71350	1100	Programs Salaries	43,042.00	10,760.49	32,281.51	25%
71350	1200	Programs Overtime	-	73.55	(73.55)	100%
71350	1300	Programs Part Time Salaries	105,671.00	28,421.12	77,249.88	27%
71350	2100	Programs FICA	11,286.00	2,981.17	8,304.83	26%
71350	2210	Programs VRS 1&2	4,442.00	1,110.48	3,331.52	25%
71350	2300	Programs Health Ins	8,047.00	1,991.91	6,055.09	25%
71350	2400	Programs Life Ins	577.00	144.18	432.82	25%
71350	2700	Programs Workers Comp	3,863.00	2,899.54	963.46	75%
71350	3000	Programs Pur Svcs	45,983.00	10,035.55	35,947.45	22%
71350	3500	Programs Printing & Binding	7,000.00	1,076.64	5,923.36	15%
71350	3600	Programs Advertising	2,000.00	-	2,000.00	0%
71350	5210	Programs Postal Svcs	100.00	-	100.00	0%
71350	5230	Programs Telephone	500.00	22.52	477.48	5%
71350	5400	Programs Leases & Rentals	300.00	-	300.00	0%
71350	5500	Programs Travel	1,000.00	300.00	700.00	30%
71350	5560	Programs Group Trip	42,284.00	455.00	41,829.00	1%
71350	5810	Programs Dues & Memb	200.00	-	200.00	0%
71350	5830	Programs Refunds	7,000.00	1,749.75	5,250.25	25%
71350	6000	Programs Mat & Sup	13,000.00	1,671.76	11,328.24	13%
71350	6011	Programs Clothing	1,500.00	-	1,500.00	0%
71350	6012	Programs Merch for Resale	6,500.00	-	6,500.00	0%
71350	8200	Programs Capital Outlay Adds	21,097.00	-	21,097.00	0%
Total 71350 Parks Programs			325,392.00	63,693.66	261,698.34	20%
71360	1300	Concession Part Time Salaries	4,945.00	3,443.27	1,501.73	70%
71360	2100	Concession FICA	379.00	263.38	115.62	69%
71360	6000	Concession Mat & Sup	100.00	-	100.00	0%
71360	6012	Concession Merch for Resale	11,100.00	5,526.58	5,573.42	50%
Total 71360 Concession Stand			16,524.00	9,233.23	7,290.77	56%
72240	5600	Barns of Rose Hill Contr	11,750.00	-	11,750.00	0%
Total 72240 Barns of Rose Hill			11,750.00	-	11,750.00	0%
72700	5600	VA Comm for Arts Contr	9,000.00	9,000.00	-	100%
Total 72700 VA Commission for the Arts			9,000.00	9,000.00	-	100%
73200	5600	Handley Regional Library Contr	279,238.00	69,809.50	209,428.50	25%
Total 73200 Handley Regional Library			279,238.00	69,809.50	209,428.50	25%
81110	1100	Plan Adm Salaries	320,414.00	78,444.51	241,969.49	24%
81110	2100	Plan Adm FICA	23,295.00	5,760.70	17,534.30	25%
81110	2210	Plan Adm VRS 1&2	32,017.00	6,766.77	25,250.23	21%
81110	2220	Plan Adm VRS Hybrid	1,104.00	1,107.36	(3.36)	100%
81110	2300	Plan Adm Health Ins	38,383.00	7,545.34	30,837.66	20%
81110	2400	Plan Adm Life Ins	4,296.00	1,051.17	3,244.83	24%
81110	2510	Plan Adm Dis Ins Hybrid	54.00	67.98	(13.98)	126%
81110	2700	Plan Adm Workers Comp	8,058.00	5,451.49	2,606.51	68%
81110	3000	Plan Adm Pur Svcs	15,000.00	3,148.50	11,851.50	21%
81110	3000	Plan Adm Pur Svcs-Brdbnd Imp	3,000.00	-	3,000.00	0%
81110	3140	Plan Adm Engineer & Architect	20,000.00	2,275.00	17,725.00	11%
81110	3140	Plan Adm Pass Thru Eng Fees	5,000.00	1,500.00	3,500.00	30%
81110	3320	Plan Adm Maint Contracts	-	947.10	(947.10)	100%
81110	3500	Plan Adm Printing & Binding	2,000.00	-	2,000.00	0%
81110	3600	Plan Adm Advert-Brdbnd Imp	1,000.00	-	1,000.00	0%
81110	5210	Plan Adm Postal Svcs	1,200.00	274.07	925.93	23%
81110	5210	Plan AdmPostal Svcs-Brdbnd Imp	1,000.00	-	1,000.00	0%
81110	5230	Plan Adm Telephone	400.00	36.00	364.00	9%
81110	5500	Plan Adm Travel	1,000.00	250.00	750.00	25%
81110	5510	Plan Adm Local Mileage	1,000.00	-	1,000.00	0%
81110	5810	Plan Adm Dues & Memb	300.00	200.00	100.00	67%

Clarke County
YTD Budget Report
September 30, 2021

FUNCTION	OBJECT	ACCOUNT DESCRIPTION	REVISED BUDGET	YTD EXPENDED	AVAILABLE BUDGET	% Used
81110	6000	Plan Adm Mat & Sup	2,500.00	412.62	2,087.38	17%
Total 81110 Planning Administration			481,021.00	115,238.61	365,782.39	24%
81120	1300	Plan Com Part Time Salaries	500.00	100.00	400.00	20%
81120	2100	Plan Com FICA	39.00	7.65	31.35	20%
81120	2700	Plan Com Workers Comp	-	10.00	(10.00)	100%
81120	3160	Plan Com Board Member Fees	8,000.00	1,100.00	6,900.00	14%
81120	3600	Plan Com Advertising	4,000.00	-	4,000.00	0%
81120	5210	Plan Com Postal Svcs	100.00	-	100.00	0%
81120	5500	Plan Com Travel	1,750.00	-	1,750.00	0%
Total 81120 Planning Commission			14,389.00	1,217.65	13,171.35	8%
81130	3160	BryDevAuth Board Member Fees	900.00	-	900.00	0%
Total 81130 Berryville Dev Authority			900.00	-	900.00	0%
81140	5600	Regional Airport Auth Contr	5,000.00	5,000.00	-	100%
Total 81140 Regional Airport Authority			5,000.00	5,000.00	-	100%
81310	5600	Help with Housing Contrib	2,500.00	-	2,500.00	0%
Total 81310 Help With Housing			2,500.00	-	2,500.00	0%
81400	1300	BrdZonApp Part Time Salaries	250.00	-	250.00	0%
81400	2100	BrdZonApp FICA	20.00	-	20.00	0%
81400	3000	BrdZonApp Pur Svcs	2,000.00	-	2,000.00	0%
81400	3160	BrdZonApp Board Member Fees	500.00	-	500.00	0%
81400	3600	BrdZonApp Advertising	700.00	-	700.00	0%
81400	5210	BrdZonApp Postal Svcs	50.00	-	50.00	0%
Total 81400 Board of Zoning Appeals			3,520.00	-	3,520.00	0%
81510	1100	Econ Dev Salaries	74,274.00	18,568.50	55,705.50	25%
81510	2100	Econ Dev FICA	5,682.00	1,434.11	4,247.89	25%
81510	2220	Econ Dev VRS Hybrid	7,666.00	1,916.28	5,749.72	25%
81510	2400	Econ Dev Life Ins	996.00	248.82	747.18	25%
81510	2510	Econ Dev Dis Ins Hybrid	393.00	98.04	294.96	25%
81510	2700	Econ Dev Workers Comp	2,189.00	1,474.68	714.32	67%
81510	3000	Econ Dev Pur Svcs	43,000.00	-	43,000.00	0%
81510	3320	Econ Dev Maint Svc Contracts	1,000.00	450.00	550.00	45%
81510	3500	Econ Dev Printing & Binding	100.00	-	100.00	0%
81510	3600	Econ Dev Advertising	7,500.00	-	7,500.00	0%
81510	5210	Econ Dev Postal Svcs	50.00	-	50.00	0%
81510	5230	Econ Dev Telephone	550.00	124.98	425.02	23%
81510	5500	Econ Dev Travel	1,000.00	-	1,000.00	0%
81510	5510	Econ Dev Local Mileage	1,000.00	-	1,000.00	0%
81510	5800	Econ Dev Miscellaneous Expendi	500.00	-	500.00	0%
81510	5810	Econ Dev Dues & Memb	12,000.00	8,651.75	3,348.25	72%
81510	6000	Econ Dev Mat & Sup	1,000.00	-	1,000.00	0%
Total 81510 Office of Economic Development			158,900.00	32,967.16	125,932.84	21%
81530	5600	Small Bus Dev Ctr Contrib	2,000.00	2,000.00	-	100%
Total 81530 Small Business Dev Center			2,000.00	2,000.00	-	100%
81540	5600	Blandy Exp Farm Contrib	3,000.00	-	3,000.00	0%
Total 81540 Blandy Experimental Farm			3,000.00	-	3,000.00	0%
81550	5600	B'ville Main St Contribution	3,500.00	3,500.00	-	100%
Total 81550 Berryville Main Street			3,500.00	3,500.00	-	100%
81800	3000	HstPrvCom Pur Svcs	9,500.00	278.17	9,221.83	3%
81800	3000	HstPrvCom Pur Svcs	31,505.00	-	31,505.00	0%
81800	3000	HPC Battle Bound Stdy Pur Svcs	-	4,002.52	(4,002.52)	100%
81800	3160	HstPrvCom Board Member Fees	1,000.00	-	1,000.00	0%
81800	3600	HstPrvCom Advertising	300.00	-	300.00	0%
81800	5210	HstPrvCom Postal Svcs	50.00	-	50.00	0%
81800	5500	HstPrvCom Travel	50.00	-	50.00	0%
Total 81800 Historic Preservation Comm			42,405.00	4,280.69	38,124.31	10%
81910	5600	NSVRC EntityGift	10,694.00	9,289.77	1,404.23	87%
Total 81910 Northern Shen Valley Reg Comm			10,694.00	9,289.77	1,404.23	87%
82210	3000	Water Qual Pur Svcs	30,000.00	-	30,000.00	0%
Total 82210 Water Quality Management			30,000.00	-	30,000.00	0%
82220	5600	Friends of Shenandoah Contr	8,000.00	8,000.00	-	100%
Total 82220 Friends of the Shenandoah			8,000.00	8,000.00	-	100%
82230	1300	BrdSepApp Part Time Salaries	200.00	-	200.00	0%
82230	2100	BrdSepApp FICA	16.00	-	16.00	0%
82230	2700	BrdSepApp Workers Comp	-	4.00	(4.00)	100%

Clarke County
YTD Budget Report
September 30, 2021

FUNCTION	OBJECT	ACCOUNT DESCRIPTION	REVISED BUDGET	YTD EXPENDED	AVAILABLE BUDGET	% Used
82230	3000	BrdSepApp Pur Svcs	500.00	-	500.00	0%
82230	3160	BrdSepApp Board Member Fees	250.00	-	250.00	0%
82230	3600	BrdSepApp Advertising	500.00	-	500.00	0%
82230	5210	BrdSepApp Postal Svcs	100.00	-	100.00	0%
Total 82230 Board of Septic Appeals			1,566.00	4.00	1,562.00	0%
82400	5600	Lord Fairfax S&W Contr	5,000.00	-	5,000.00	0%
Total 82400 LF Soil & Water Cons Dist			5,000.00	-	5,000.00	0%
82600	1300	Biosolids Part Time Salaries	1,000.00	220.00	780.00	22%
82600	2100	Biosolids FICA	77.00	16.83	60.17	22%
82600	2700	Biosolids Workers Comp	29.00	20.00	9.00	69%
Total 82600 Bio-solids Application			1,106.00	256.83	849.17	23%
83100	3320	Coop Ext Maint Contracts	800.00	158.39	641.61	20%
83100	3841	Coop Ext VPI Agent	48,984.00	-	48,984.00	0%
83100	5210	Coop Ext Postal Svcs	500.00	63.13	436.87	13%
83100	5230	Coop Ext Telephone	200.00	-	200.00	0%
83100	5810	Coop Ext Dues & Memb	150.00	-	150.00	0%
83100	6000	Coop Ext Mat & Sup	1,500.00	-	1,500.00	0%
Total 83100 Cooperative Extension Program			52,134.00	221.52	51,912.48	0%
83400	5600	4-H Center EntityGift	2,500.00	-	2,500.00	0%
Total 83400 4-H Center			2,500.00	-	2,500.00	0%
91600	1000	Reserve Personal	20,000.00	-	20,000.00	0%
91600	3140	Reserve Engineer & Architect	5,000.00	-	5,000.00	0%
91600	3150	Reserve Legal Svcs	10,000.00	-	10,000.00	0%
91600	8000	Reserve Capital Outlay	20,000.00	-	20,000.00	0%
Total 91600 Contingency Reserves			55,000.00	-	55,000.00	0%
Grand Total			15,625,484.00	3,241,690.29	12,383,793.71	21%

Date	Total	General Fund	Soc Svcs Fund	CSA Fund	Sch Oper Fund	Food Serv Fund	GG Cap Fund	School Cap Fund	GG Debt Fund	School Debt Fund	Joint Fund	Conservation Easements	Unemploy. Fund	TOTAL
04/20/21 Appropriations Resolution: Total	45,268,643	12,741,076	1,715,358	314,556	24,165,588	800,996	1,452,700	616,000	251,700	2,365,130	790,539	45,000	10,000	
<i>Adjustments:</i>														
7/20/2021 Social Services-Adoption Incentive Funds			4,309											
7/20/2021 Registrar-salary increase per VA Dept of Elections		18,177												
7/20/2021 Consvr Easement purchase-Lizzie Moon												80,713		
7/20/2021 Consvr Easement purchase-Smithfield Farm												566,125		
7/20/2021 Barns of Rose Hill-Endowment Match		5,000												
7/20/2021 Coronavirus-American Rescue Plan funds (CLFRF)		2,839,569												
7/20/2021 Clarke Co Schools-ESSER III ARP funds					1,270,045									
7/20/2021 Clarke Co Schools-IDEA Part B-611 ARP funds					99,547									
8/17/2021 History through Architecture Book, Clarke County		29,005												
9/21/2021 Sheriff's Office-State Compensation Board		41,984												
10/19/2021 <i>FY21 Government Capital Carryforward</i>							849,740							
10/19/2021 <i>FY21 School Capital Carryforward</i>								669,431						
Revised Appropriation	51,742,288	15,674,811	1,719,667	314,556	25,535,180	800,996	2,302,440	1,285,431	251,700	2,365,130	790,539	691,838	10,000	
Change to Appropriation	6,473,645	2,933,735	4,309	0	1,369,592	0	849,740	669,431	0	0	0	646,838	0	
Original Revenue Estimate	17,723,491	3,533,020	1,076,325	163,569	10,818,016	800,996	932,095	154,000		200,470	0	45,000	0	
<i>Adjustments:</i>														
7/20/2021 Social Services-Adoption Incentive Funds			4,309											
7/20/2021 Registrar-salary increase per VA Dept of Elections		10,482												
7/20/2021 Consvr Easement purchase-Lizzie Moon												40,357		
7/20/2021 Consvr Easement purchase-Smithfield Farm												490,125		
7/20/2021 Coronavirus-American Rescue Plan funds		2,839,569												
7/20/2021 Clarke Co Schools-ESSER III ARP funds					1,270,045									
7/20/2021 Clarke Co Schools-IDEA Part B-611 ARP funds					99,547									
8/17/2021 History through Architecture Book, Clarke County		29,005												
9/21/2021 Sheriff's Office-State Compensation Board		41,984												
10/19/2021 <i>FY21 Government Capital Carryforward</i>							241,452							
10/19/2021 <i>FY21 School Capital Carryforward</i>								198,568						
Revised Revenue Estimate	22,988,933	6,454,060	1,080,634	163,569	12,187,608	800,996	1,173,547	352,568	0	200,470	0	575,482	0	
Change to Revenue Estimate	5,265,442	2,921,040	4,309	0	1,369,592	0	241,452	198,568	0	0	0	530,482	0	
Original Local Tax Funding	27,545,152	9,208,056	639,033	150,987	13,347,572	0	520,605	462,000	251,700	2,164,660	790,539	0	10,000	
Revised Local Tax Funding	28,753,355	9,220,751	639,033	150,987	13,347,572	0	1,128,893	932,863	251,700	2,164,660	790,539	116,357	10,000	
Change to Local Tax Funding	1,208,203	12,695	0	0	0	0	608,288	470,863	0	0	0	116,357	0	

Italics = Proposed actions

10/05/2021 12:22
2600bbennett

Clarke County
YEAR-TO-DATE BUDGET REPORT

P 1
glytbdud

FOR 2022 13

	ORIGINAL APPROP	TRANFRS/ ADJSTMTS	REVISED BUDGET	YTD EXPENDED	ENC/REQ	AVAILABLE BUDGET	PCT USED
301 General Govt Capital Proj Fund							
000 Non-Categorical							
94110 HVAC System Replacement	225,000	7,343	232,343	7,500.00	17,703.00	207,140.00	10.8%
94331 Sheriff's Vehicles	174,000	0	174,000	37,176.40	57,387.36	79,436.24	54.3%
94601 Technology Improvements	0	0	0	4,000.00	.00	-4,000.00	100.0%
94603 Mobile Radio System	75,000	0	75,000	302,832.20	94,727.29	-322,559.49	530.1%
94604 911 Phone System	0	0	0	12,150.84	10,974.83	-23,125.67	100.0%
94802 Reassessment	0	0	0	14,784.00	.00	-14,784.00	100.0%
TOTAL Non-Categorical	474,000	7,343	481,343	378,443.44	180,792.48	-77,892.92	116.2%
666 Assistance Firefighters-Radios							
94329 AFG-Radio Replacements	978,700	0	978,700	.00	.00	978,700.00	.0%
TOTAL Assistance Firefighters-Radios	978,700	0	978,700	.00	.00	978,700.00	.0%
TOTAL General Govt Capital Proj Fund	1,452,700	7,343	1,460,043	378,443.44	180,792.48	900,807.08	38.3%
GRAND TOTAL	1,452,700	7,343	1,460,043	378,443.44	180,792.48	900,807.08	38.3%

** END OF REPORT - Generated by Brenda Bennett **

Clarke County Board of Supervisors

Government Projects Update

Clarke County Board of Supervisors

Miscellaneous Items

Board of Supervisors
Summary of Required Actions Status Report

<i>Description</i>	<i>Responsibility</i>	<i>Status</i>	<i>Date Complete</i>
Reach out to Don Jackson to see if he could attend the October Evening Session	Brian Lichty	Complete	9/23/2021
Process approved minutes for August 17, 2021, Regular Meeting Minutes & August 31, 2021, Special Meeting Minutes	Brianna T. Taylor	Complete	9/30/2021
Advertise the Public Hearing Notices	Brandon Stidham	Complete	9/30/2021
Execute notice of appointments	David S. Weiss	Complete	9/24/2021
Process appointments and update the database	Brianna R. Taylor	Complete	9/27/2021
Execute the Annexation Agreement	David S. Weiss	Complete	9/21/2021
Process the Annexation Agreement	Brianna R. Taylor	Complete	9/22/2021
Process Health Department Carryforward Request	Brenda Bennett	Complete	9/21/2021
Process Sheriff's Office Bonuses	Brenda Bennett	Complete	10/13/2021
Process Bills and Claims	Brenda Bennett	Complete	9/21/2021
Email meeting date options for Legislative Priorities Meeting to Board and Legislators	Brianna R. Taylor	Complete	9/29/2021

Upon completion, please provide status update to Brianna R. Taylor for database entry.

Clarke County Board of Supervisors - Board Member Committee Status Reports

Matthew E. Bass

- Board of Septic & Well Appeals BoS - Appointed Member
- Clarke County Library Advisory Council BoS - Liaison
- Clarke County Litter Committee BoS - Liaison
- Clarke County Planning Commission BoS - Appointed Member
- Clarke County Sheriff's Office BoS - Liaison
- Josephine School Community Museum Board BoS - Liaison
- Legislative Liaison and High Growth Coalition BoS - Liaison
- Northwestern Regional Adult Drug Treatment Court Advisory Committee BoS - Appointed Member
- Northwestern Regional Juvenile Detention Center Commission BoS - Liaison
- Towns and Villages: Berryville BoS - Liaison

Terri T. Catlett

- Board of Supervisors Finance Committee, BoS - Appointed Member
- Career and Technical Education Advisory Committee BoS - Appointed Member
- Clarke County Historic Preservation Commission BoS - Liaison
- Clarke County Humane Foundation BoS - Liaison
- Clarke County School Board BoS - Liaison
- Community Policy and Management Team BoS - Appointed Member
- Conservation Easement Authority BoS - Appointed Member
- Parks & Recreation Advisory Board BoS - Liaison
- Strategic Planning Committee BoS - Appointed Member
- Towns and Villages: Millwood BoS - Liaison
- Towns and Villages: Pine Grove BoS - Liaison

Doug M. Lawrence

- Berryville/Clarke County Joint Committee for Economic Development and Tourism BoS - Appointed Member

- Board of Social Services BoS - Appointed Member
- Broadband Implementation Committee BoS - Appointed Member
- Northwestern Regional Jail Authority BoS - Liaison

Beverly B. McKay

- Agricultural & Forestal District Advisory Committee BoS - Appointed Member
- BCCGC Joint Building Committee BoS - Appointed Member
- Board of Supervisors Personnel Committee BoS - Appointed Member
- Broadband Implementation Committee BoS - Appointed Member
- Building and Grounds BoS - Appointed Member
- Clarke County Sanitary Authority BoS - Liaison
- Economic Development Advisory Committee BoS - Appointed Member
- Housing and Community Services Board BoS - Appointed Member
- Northern Shenandoah Valley Regional Commission BoS - Appointed Member
- Towns and Villages: Boyce BoS - Liaison
- Towns and Villages: White Post BoS - Liaison

David S. Weiss

- Berryville/Clarke County Joint Committee for Economic Development and Tourism
- Board of Supervisors Finance Committee BoS - Appointed Member
- Board of Supervisors Personnel Committee BoS - Appointed Member
- Emergency Services BoS - Chair
- Fire & EMS Commission BoS - Representative
- Industrial Development Authority of the Clarke County BoS - Liaison
- Joint Administrative Services Board BoS - Appointed Member
- Towns and Villages: Pine Grove BoS - Liaison

Clarke County Board of Supervisors

Closed Session

- Pursuant to §2.2-3711-A8 Consultation with legal counsel regarding specific legal matter(s).

Clarke County Board of Supervisors

Citizen's Comment Period

Clarke County Board of Supervisors

2021-20R: Resolution of Recognition and Appreciation of Donald “Don” Jackson

Clarke County Board of Supervisors



Berryville Voting District
Matthew E. Bass
(540) 955-5175

Millwood Voting District
Terri T. Catlett
(540) 837-2328

Russell Voting District
Doug Lawrence
(540) 955-2144

Buckmarsh Voting District
David S. Weiss – Chair
(540) 955-2151

White Post Voting District
Bev B. McKay – Vice Chair
(540) 837-1331

County Administrator
Chris Boies
(540) 955-5175

Resolution of Recognition and Appreciation of Donald 'Don' Jackson

2021-20R

WHEREAS, Donald 'Don' Jackson assumed the duties and responsibilities of EMS Supervisor for the Department of Fire, EMS, & Emergency Management on September 14, 2000, and retired on August 31, 2021 as the EMS Lieutenant; after 21 years of service;

WHEREAS, he came to Clarke County with extensive Fire & EMS experience; and has now been a firefighter for 44 years, a fire officer for 38 years, and a medic for 38 years, and he has mentored countless volunteers and career staff during these decades of service. Before coming to Clarke County, he retired as a detective from the New York Police Department;

WHEREAS, during his career, he managed most of the department's day-to-day operations and coordinated the hiring of full-time and part-time employees prior to the hiring of the Director position. He managed the scheduling of employees both full-time and part-time for most of his 21 years and managed the scheduling of new employee ability testing;

WHEREAS, under his leadership, Clarke County piloted a regional 12-lead EKG transmission program that evolved into our current system of Cardiac Care. Now medics avoid the emergency room and transport patients directly into the Cardiac Cath lab at Winchester Medical Center; this timesaving initiative is region-wide, saves lives, and improves the quality of life for patients daily;

WHEREAS, throughout his career, he worked as a liaison between career and volunteer members, he has served as the Chief of Gainsboro Fire and Rescue in Frederick County since 2000, and was instrumental in the development of the Clarke County Fire & EMS Commission;

WHEREAS, in his tenure, he has been and continues to be a knowledgeable and effective instructor in fire suppression, incident command, apparatus design and operation, building construction, leadership, radio communications, firefighter safety, emergency medical care, and law enforcement. He is active in the mental health care of first responders by being a certified Critical Incident Stress Debriefing;

NOW, THEREFORE, BE IT RESOLVED by the Clarke County Board of Supervisors that Donald 'Don' Jackson be recognized and congratulated for his service and dedication to all citizens of Clarke County.

APPROVED AND ORDERED ENTERED in the official records by the unanimous vote of the Clarke County Board of Supervisors' members assembled on the 19th day of October 2021.

ATTEST 2021-20R



David S. Weiss, Chair

Clarke County Board of Supervisors

Virginia Department of Wildlife Resources Update, District Wildlife Biologist Fred Frenzel

Clarke County Board of Supervisors

PH 2021-11: Code Change, CC 2021-04: Repeal of Chapter 78 Dance Halls

COUNTY CODE TEXT AMENDMENT (CC-2021-04)
Repeal of Chapter 78 – Dance Halls
October 19, 2021 Board of Supervisors Meeting – PUBLIC HEARING
STAFF REPORT – Department of Planning

The purpose of this staff report is to provide information to the Board of Supervisors to assist them in reviewing this proposed text amendment to the Code of Clarke County. It may be useful to members of the general public interested in this proposed amendment.

Description:

Proposed text amendment to repeal in its entirety Chapter 78, Dance Halls, of the Code of Clarke County. The purpose is to remove this Chapter as “public dance halls” are not an allowable use per Chapter 200, Clarke County Zoning & Subdivision Ordinances, Article I (Zoning Ordinance), §5 (Uses).

Code of Virginia Authority:

- Va. Code §15.2-912.3, Regulation of dance halls by counties, cities, and towns

Requested Action:

Conduct scheduled Public Hearing and take formal action on the proposed text amendment. Staff has no outstanding concerns with the adoption of this text amendment.

Staff Discussion/Analysis:

During the recent project to revise the County’s Zoning and Subdivision Ordinances, Staff identified a conflict with Chapter 78, Dance Halls, of the Code of Clarke County and the County’s Zoning Ordinance (now Chapter 200, Article I). Chapter 78, which is not part of the Zoning Ordinance, contains a permitting process and regulations for “public dance halls” which are defined as follows:

Any place, open to the general public, where dancing is permitted, to which an admission fee is charged or for which compensation is in any manner received, either directly or indirectly, by cover charge or otherwise, or where refreshments or food or any form of merchandise are served for compensation before, during or after dancing; and the sale of any refreshments, food or any form of merchandise at such place or the exhibiting of such for sale shall be deemed direct compensation for any such dance hall as is contemplated by this chapter. A public dance hall shall also mean any place where any club, association, corporation, organization or group of persons conduct, operate or permit dances that are open to the public.

Uses of lands and structures are regulated by the Zoning Ordinance. Zoning Ordinance §5 contains a listing of all allowable uses by zoning district but does not include “public dance halls” or any similar use. In order to resolve the conflict, Staff recommends that Chapter 78 be repealed. The County currently does not have a formal process for issuing “public dance hall” permits under Chapter 78 and Staff is unaware of any such permits or approvals being issued in recent memory. Additionally, there are no “public dance halls” currently operating in Clarke County. Elimination of Chapter 78 would allow the activity to be regulated within the scope of the uses and regulatory processes in the Zoning Ordinance. Dancing would be a permissible

commercial activity in conjunction with uses that allow for musical performances and entertainment as accessory activities such as restaurants, minor commercial public assembly, and private club uses.

Staff Recommendation:

Staff has no outstanding concerns with the adoption of the text amendment.

History:

- | | |
|----------------------------|---|
| September 21, 2021. | Board voted unanimously to schedule Public Hearing for the October 19, 2021 meeting. |
| October 19, 2021. | Placed on the Board’s October meeting agenda and advertised for Public Hearing. |

**PH 2021-12: Code Change CC
2021-05: Repeal of Chapter
189 Outdoor Lighting in
Agricultural, Forestal, and
Rural Residential Areas**

COUNTY CODE TEXT AMENDMENT (CC-2021-05)

Repeal of Chapter 189 – Outdoor Lighting in Agricultural, Forestal, and Rural Residential Areas

October 19, 2021 Board of Supervisors Meeting – PUBLIC HEARING

STAFF REPORT – Department of Planning

The purpose of this staff report is to provide information to the Board of Supervisors to assist them in reviewing this proposed text amendment to the Code of Clarke County. It may be useful to members of the general public interested in this proposed amendment.

Description:

Proposed text amendment to repeal in its entirety Chapter 189, Outdoor Lighting in Agricultural, Forestal, and Rural Residential Areas, of the Code of Clarke County. The purpose is to remove this chapter as its provisions have been incorporated into Chapter 200, Clarke County Zoning & Subdivision Ordinances, Article I (Zoning Ordinance).

Requested Action:

Conduct scheduled Public Hearing and take formal action on the proposed text amendment. Staff has no outstanding concerns with the adoption of this text amendment.

Staff Discussion/Analysis:

Chapter 189 regulates the placement, orientation, distribution patterns, and fixture type of outdoor lighting on County properties that are zoned Agricultural-Open Space-Conservation (AOC), Forestal-Open Space-Conservation (FOC), or Rural Residential (RR). Regulations are included in this chapter to promote safety, utility and security; prevent glare on public rights of ways and light trespass onto adjoining properties; protect the privacy of adjacent property owners; and reduce atmospheric light pollution.

Chapter 189 was adopted by the Board of Supervisors in January 2007 as a new section of the Code of Clarke County following review and recommendation by the Planning Commission. Similar outdoor lighting regulations are included in the County Zoning Ordinance for uses on commercially-zoned properties. Staff’s review of the record for the original adoption of Chapter 189 shows no discussion or stated rationale for placing the regulations in the County Code instead of in the Zoning Ordinance.

Regulations that have a relationship to planning and zoning matters are placed in the County Code either because they are governed by an ordinance other than Zoning or Subdivision (e.g., erosion and sediment control, wells, septic systems) or because the governing body chooses to enforce the matter via its police powers. In the latter case, enforcement responsibility is specifically delegated to an entity other than the Zoning Administrator such as the Building Department or the Sheriff’s Office. Chapter 189 has no language delegating enforcement responsibility to any agency or department.

Because no rationale was identified for maintaining these regulations in a County Code chapter separate from the Zoning Ordinance, these regulations were incorporated into the revised Zoning Ordinance (Chapter 200, Article I) that was adopted by the Board of Supervisors in August 2021.

Requirements for outdoor lighting in the AOC and FOC Districts are now found in Section 7.4.3, and requirements for properties in the RR District are found in Section 7.5.1. Enforcement of these requirements are now assigned to the Zoning Administrator.

With the incorporation of Chapter 189's provisions into the Zoning Ordinance, Chapter 189 is now redundant and can be removed in its entirety from the Code of Clarke County.

Staff Recommendation:

Staff has no outstanding concerns with the adoption of the text amendment.

History:

September 21, 2021. Board voted unanimously to schedule Public Hearing for the October 19, 2021 meeting.

October 19, 2021. Placed on the Board's October meeting agenda and advertised for Public Hearing.

**PH 2021-13: Code Change, CC
2021-06: Assignment of New
Addresses to Existing
Addressed Structures
Chapter 56 County Road
Naming, Property Numbering
and Road Sign System**

COUNTY CODE TEXT AMENDMENT (CC-2021-06)
Assignment of New Addresses to Existing Addressed Structures
Chapter 56 – County Road Naming, Property Numbering and Road Sign System
October 19, 2021 Board of Supervisors Meeting – PUBLIC HEARING
STAFF REPORT – Department of Planning

The purpose of this staff report is to provide information to the Board of Supervisors to assist them in reviewing this proposed text amendment to the Code of Clarke County. It may be useful to members of the general public interested in this proposed amendment.

Description:

Proposed text amendment to amend §56.4, Official Address, of the Code of Clarke County. The purpose is to clarify the situations in which the County may assign a new address to an existing addressed structure.

Requested Action:

Conduct scheduled Public Hearing and take formal action on the proposed text amendment. Staff has no outstanding concerns with the adoption of this text amendment.

Staff Discussion/Analysis:

Chapter 56 of the Code of Clarke County contains the regulations for naming of public roads and private access easements, the assignment of street addresses, and the installation and maintenance of street name signage. The County’s street naming and address assignment regulations are an integral component of the County’s emergency communications program, and appropriate addressing of structures is necessary to ensure optimal response times for fire, rescue, and law enforcement personnel.

The County’s authority to assign addresses to structures is provided by Code of Virginia §15.2-2024, Numbers to be displayed on buildings. §56-4 of the County Code contains the regulations for assigning official addresses, and addresses are assigned using a formula based on the point where the property’s primary means of ingress/egress to a public road or private access easement is located. Subsection (e) states that the County can assign a new address if the property owner moves the location, however this is not the only situation in which a previously addressed structure must be assigned a new address.

The most common example of a structure needing to be re-addressed involves unnamed private access easements. As a rule of thumb, a private access easement is not assigned a street name until three or more addressable structures are constructed and will use that private access easement as the primary means of ingress/egress to a public road. A house that is located on a private access easement with no more than one other addressable structure also using the private access easement will likely be addressed on the public road. If a third addressable structure is constructed on the private access easement, that private access easement would be assigned a street name, the new structure would be addressed using the new name, and the existing house and other existing structure would be assigned a new address on the newly-named private access easement.

Other situations requiring a structure to be re-addressed can be based on the recommendation of the County’s emergency communications center, fire, rescue, law enforcement, or emergency management officials. These situations arise when confusion or other problems locating properties delay first responders in answering calls for assistance. This could be due to original addressing errors or caused by changes to private access easements or property conditions that hamper first responders in finding addressed properties and incident locations.

The County currently has the authority per the Code of Virginia to assign a new address to a structure that was previously addressed. The proposed text amendment would promote clarity by identifying all of the likely scenarios where re-addressing may occur and emphasizing that optimizing emergency response times is a critical factor in deciding whether to re-address a property in certain cases.

Staff Recommendation:

Staff has no outstanding concerns with the adoption of the text amendment.

History:

September 21, 2021. Board voted unanimously to schedule Public Hearing for the October 19, 2021 meeting.

October 19, 2021. Placed on the Board’s October meeting agenda and advertised for Public Hearing.

PROPOSED AMENDMENT LANGUAGE

§ 56-4 Official Address

- a) The street name and number assigned to each property within the county shall be the official address of such property for all purposes.
- b) Requests for new addresses shall be made by the property owner or authorized representative.
- c) By requesting an official address, the property owner attests that they have the legal right to access their property at the location on the public or private road upon which the address will be assigned. Assignment of an official address by the County shall not be construed as official determination of a property owner’s legal right to access their property at that location.

- d) An official address shall only be assigned to driveways constructed to permit ingress/egress by emergency response vehicles unless no other feasible alternatives exist.
- e) **The County may assign a new official address to conform with the structure numbering system *including but not limited to the following situations:***
- (1) If a property owner moves the driveway access point after issuance of an official address.**
 - (2) *If, in the case of an unnamed private access easement, additional structures are addressed which necessitate the assignment of an official street name to the private access easement and issuance of new addresses to all addressed structures that use the private access easement as the primary means of ingress/egress to a public road or another named private access easement.***
 - (3) *Any other situation in which it is the opinion of the County's Emergency Communications Center Director and/or the Director of Fire, Emergency Medical Services, and Emergency Operations that issuance of a new address or addresses to an existing structure or structures is necessary to ensure efficient provision of emergency services.***
- ~~e) If a property owner moves the driveway access point after issuance of an official address, the County may assign a new official address to conform with the structure numbering system.~~

Clarke County Board of Supervisors

Adjournment

Clarke County Board of Supervisors

Reports:

- Building Department
- Commissioner of the Revenue
- Fire & EMS
- Virginia Regional Transit Clarke Metrics Report
- Barns of Rose Hill 2020 Annual Report

Building Department - Clarke County
New Single Family Dwellings 2021

	Battletown	Berryville	Boyce	Chapel	Greenway	Longmarsh	TOTAL	COMMENTS			
January		5					5				
February		8					8				
March		6		1	1		8				
April		7		1	1		9				
May	1	14				1	16				
June	1	3		1	1	1	7				
July	3	3		1	1	2	10				
August	1	8			1	1	11				
September	1	14				2	17				
October											
November											
December											
TOTAL	7	68	0	4	5	7	91				

10/01/2021 08:42
2600mshayeb

Clarke County
INSPECTION REPORT

P 1
piinhrpt

Building Inspections

INSPECTIONS PERFORMED: 09/01/21 to 09/30/21

INSPECTION	DATE	BY	RSLT	PROJECT	CITY	AREA	LOCATION	OWNER	INSP ID	T
Final Closing Buildi	09/01/21	DS	P	Rmdl Res	BVL	BVL	308 SOUTH CHURCH ST	HUDSON JOHN E & KATHLEE	21428	A
Final Closing Plumbi	09/01/21	DS	P	Rmdl Res	BYC	CHPL	3968 CALMES NECK LN	TORCZON RICHARD L JR &	21346	A
Final Closing Buildi	09/01/21	DS	P	Rmdl Res	BYC	CHPL	3968 CALMES NECK LN	TORCZON RICHARD L JR &	21347	A
Shower Pan	09/01/21	DS	P	Rmdl Res	BYC	GNWY	3155 SWIFT SHOALS RD	KELBLE JEFFREY D	21395	A
Electric Service	09/01/21	DS	P	NRSF	BVL	LNGM	135 DOLEMAN LN	WARFIELD HOMES INC	19995	A
Final Closing Electr	09/02/21	DS	P	NRSF	BVL		14 PULLIAM CT	D R HORTON INC	21471	A
Final Closing Plumbi	09/02/21	DS	P	NRSF	BVL		14 PULLIAM CT	D R HORTON INC	21472	A
Final Closing Mechan	09/02/21	DS	P	NRSF	BVL		14 PULLIAM CT	D R HORTON INC	21473	A
Final Closing Gas	09/02/21	DS	P	NRSF	BVL		14 PULLIAM CT	D R HORTON INC	21474	A
Final Closing Buildi	09/02/21	DS	P	NRSF	BVL		14 PULLIAM CT	D R HORTON INC	21475	A
Fire Off Mechanical	09/02/21	DS	P	NRSF			509 HARPER DR	D R HORTON INC	21421	A
Final Closing Buildi	09/02/21	DS	P	Deck/Porch		BLTN	1184 PARKER LN	STONE MARY PATRICIA TRU	20656	A
Footings	09/02/21	DS	P	Deck/Porch	BVL	BVL	413 HANCOCK CT	MOORE ROBERT C & CYNTHI	20628	A
Slab	09/02/21	DS	P	Deck/Porch	BVL	BVL	413 HANCOCK CT	MOORE ROBERT C & CYNTHI	21431	A
Final Closing Buildi	09/02/21	DS	P	Deck/Porch	BVL	BVL	500 BURWELL CT	WRYE PAUL STEPHEN & TES	20079	A
Footings	09/02/21	DS	P	Deck/Porch	BVL	BVL	795 MCGUIRE CIR	BROWN RUSSELL S & JOANN	21219	A
Slab Garage/Carport	09/02/21	DS	P	Garage	PRS	CHPL	112 STONE RIDGE LN	DOHERTY OWEN	21429	A
Framing	09/03/21	DS	P	Deck/Porch		BLTN	1184 PARKER LN	STONE MARY PATRICIA TRU	20655	A
Final Closing Buildi	09/03/21	DS	P	Accessory	BLMT	BLTN	309 HEMLOCK LN	CALLIS DEBORAH LYNN & R	21380	A
Footings	09/03/21	DS	P	Deck/Porch	BLMT	BLTN	346 DOGWOOD LN	WINE EARL M JR & SHARON	21237	A
Framing	09/03/21	DS	P	Deck/Porch	BVL	BVL	500 BURWELL CT	WRYE PAUL STEPHEN & TES	20078	A
Final Closing Buildi	09/03/21	DS	P	Tents Lrg	WHPT	GNWY	830 LONG BRANCH LN	ISAACS HARRY Z	18842	A
Slab Basement	09/03/21	DS	P	NRSF	BVL	LNGM	235 CATHER RD	CONDREY JOSEPH B & ALYS	21447	A
Bonding Pool	09/03/21	DS	P	SPAG	BVL	LNGM	723 CLIFTON RD	ROBERTS JAMES W III & L	21442	A
Ditch Electric	09/03/21	DS	P	SPAG	BVL	LNGM	723 CLIFTON RD	ROBERTS JAMES W III & L	21443	A
Slab Garage/Carport	09/03/21	DS	P	Garage	BVL	LNGM	802 TRIPLE J RD	BARNETTE ROBERT S	21367	A
Gas Rough In	09/07/21	DS	P	NRSF			504 HARPER DR	D R HORTON INC	21463	A
Electrical Rough In	09/07/21	DS	P	NRSF			504 HARPER DR	D R HORTON INC	19774	A
Electric Service	09/07/21	DS	P	NRSF			504 HARPER DR	D R HORTON INC	19775	A
Plumbing Rough In	09/07/21	DS	P	NRSF			504 HARPER DR	D R HORTON INC	19778	A
Mechanical Rough In	09/07/21	DS	P	NRSF			504 HARPER DR	D R HORTON INC	19780	A
Framing	09/07/21	DS	P	NRSF			504 HARPER DR	D R HORTON INC	19772	A
Electrical Rough In	09/07/21	DS	P	NRSF			508 HARPER DR	D R HORTON INC	19746	A
Electric Service	09/07/21	DS	P	NRSF			508 HARPER DR	D R HORTON INC	19747	A
Plumbing Rough In	09/07/21	DS	P	NRSF			508 HARPER DR	D R HORTON INC	19750	A
Mechanical Rough In	09/07/21	DS	P	NRSF			508 HARPER DR	D R HORTON INC	19752	A
Framing	09/07/21	DS	P	NRSF			508 HARPER DR	D R HORTON INC	19744	A
Gas Rough In	09/07/21	DS	P	NRSF			508 HARPER DR	D R HORTON INC	21464	A
Footings	09/07/21	DS	F	NRSF	BYC		86 VICTORY LN	HURTADO PEDRO	21157	A
Insulation	09/10/21	DS	P	NRSF			508 HARPER DR	D R HORTON INC	21636	A
Insulation	09/10/21	DS	P	NRSF			512 HARPER DR	D R HORTON INC	19728	A
Final Closing Electr	09/10/21	DS	P	NRSF	BVL		64 WILSON DR	D R HORTON INC	21637	A
Final Closing Plumbi	09/10/21	DS	P	NRSF	BVL		64 WILSON DR	D R HORTON INC	21650	A
Final Closing Mechan	09/10/21	DS	P	NRSF	BVL		64 WILSON DR	D R HORTON INC	21651	A
Final Closing Gas	09/10/21	DS	P	NRSF	BVL		64 WILSON DR	D R HORTON INC	21652	A
Final Closing Buildi	09/10/21	DS	P	NRSF	BVL		64 WILSON DR	D R HORTON INC	21653	A
Final Closing Gas	09/10/21	DS	F	NRSF	BVL		68 WILSON DR	D R HORTON INC	21469	A
Final Closing Electr	09/10/21	DS	F	NRSF	BVL		68 WILSON DR	D R HORTON INC	18906	A
Final Closing Plumbi	09/10/21	DS	F	NRSF	BVL		68 WILSON DR	D R HORTON INC	18909	A
Final Closing Mechan	09/10/21	DS	F	NRSF	BVL		68 WILSON DR	D R HORTON INC	18911	A
Final Closing Buildi	09/10/21	DS	F	NRSF	BVL		68 WILSON DR	D R HORTON INC	18912	A
Electrical Rough In	09/10/21	DS	P	Add Res	BVL	BVL	116 HERMITAGE BLVD	ROHRBACH SCOTT	21551	A

10/01/2021 08:42
2600mshayeb

Clarke County
INSPECTION REPORT

P 2
piinhrpt

Building Inspections

INSPECTIONS PERFORMED: 09/01/21 to 09/30/21

INSPECTION	DATE	BY	RSLT	PROJECT	CITY	AREA	LOCATION	OWNER	INSP ID	T
Gas Tank	09/10/21	DS	P	NRSF	BVL	CHPL	277 KINSKY LN	EYCHNER DENNIS W & KATH	21584	A
Gas Line	09/10/21	DS	P	NRSF	BVL	CHPL	277 KINSKY LN	EYCHNER DENNIS W & KATH	21585	A
Final Closing Buildi	09/10/21	DS	P	Tents Lrg	BVL	CHPL	2821 LOCKES MILL RD	MALENKI ANDREW & BARBAR	20164	A
Final Closing Buildi	09/10/21	DS	P	Tents Lrg	WHPT	GNWY	830 LONG BRANCH LN	ISAACS HARRY Z	18840	A
Plumbing Groundworks	09/14/21	DS	P	NRSF			601 WEEKS CT	D R HORTON INC	20966	A
Sewer Line	09/14/21	DS	P	NRSF			601 WEEKS CT	D R HORTON INC	21576	A
Water Line	09/14/21	DS	P	NRSF			601 WEEKS CT	D R HORTON INC	21577	A
Sewer Line	09/14/21	DS	P	NRSF			608 WEEKS CT	D R HORTON INC	21574	A
Water Line	09/14/21	DS	P	NRSF			608 WEEKS CT	D R HORTON INC	21575	A
Plumbing Groundworks	09/14/21	DS	P	NRSF			608 WEEKS CT	D R HORTON INC	20952	A
Plumbing Groundworks	09/14/21	DS	P	NRSF			616 WEEKS CT	D R HORTON INC	21040	A
Sewer Line	09/14/21	DS	P	NRSF			616 WEEKS CT	D R HORTON INC	21572	A
Water Line	09/14/21	DS	P	NRSF			616 WEEKS CT	D R HORTON INC	21573	A
Final Closing Electr	09/14/21	DS	F	NRSF	BVL		68 WILSON DR	D R HORTON INC	21604	A
Final Closing Plumbi	09/14/21	DS	F	NRSF	BVL		68 WILSON DR	D R HORTON INC	21605	A
Final Closing Mechan	09/14/21	DS	F	NRSF	BVL		68 WILSON DR	D R HORTON INC	21606	A
Final Closing Gas	09/14/21	DS	F	NRSF	BVL		68 WILSON DR	D R HORTON INC	21607	A
Final Closing Mechan	09/14/21	DS	P	MechPer-R	BYC	GNWY	886 CAREFREE LN	CLAY FORREST PATRICK	21596	A
Insulation	09/15/21	DS	P	NRSF			505 HARPER DR	D R HORTON INC	19563	A
Gas Line	09/15/21	DS	P	Gas Per-R	BVL	BLTN	260 BOOM RD	KINSEY KENT ROBERT & BA	21613	A
Gas Line Pressure Te	09/15/21	DS	P	Gas Per-R	BVL	BLTN	260 BOOM RD	KINSEY KENT ROBERT & BA	21614	A
Framing	09/15/21	DS	F	Deck/Porch	BLMT	BLTN	346 DOGWOOD LN	WINE EARL M JR & SHARON	21238	A
DrainTile	09/15/21	DS	P	NRSF	BLMT	BLTN	881 RETREAT RD	VILLAR ROBERT R	21718	A
Waterproofing/Pargin	09/15/21	DS	P	NRSF	BLMT	BLTN	881 RETREAT RD	VILLAR ROBERT R	21719	A
Framing	09/15/21	DS	P	Deck/Porch	BVL	BVL	113 TYSON DR	GRAVES CHARLES A II & S	19022	A
Final Closing Buildi	09/15/21	DS	P	Deck/Porch	BVL	BVL	113 TYSON DR	GRAVES CHARLES A II & S	19023	A
Framing	09/15/21	DS	P	Add Res	BVL	BVL	116 HERMITAGE BLVD	ROHRBACH SCOTT	20081	A
Footings	09/15/21	DS	P	Deck/Porch	BVL	BVL	795 MCGUIRE CIR	BROWN RUSSELL S & JOANN	21655	A
Electric Service	09/15/21	DS	P	ELEC RES	BYC	CHPL	1776 OLD WINCHESTER RD	HILL JIMMY L & ELIZABET	21506	A
Gas Line	09/15/21	DS	F	Gas Per-R	BYC	CHPL	485 RUNNING BEAR LN	MITCHELL MARK	21673	A
Gas Tank	09/15/21	DS	F	Gas Per-R	BYC	CHPL	485 RUNNING BEAR LN	MITCHELL MARK	21692	A
Gas Tank	09/16/21	DS	P	NRSF	BVL		135 DOLEMAN LN	WARFIELD HOMES INC	21664	A
Gas Line	09/16/21	DS	P	NRSF	BVL		135 DOLEMAN LN	WARFIELD HOMES INC	21665	A
Final Closing Buildi	09/16/21	DS	PWC	NRSF	BVL		68 WILSON DR	D R HORTON INC	21687	A
Final Closing Electr	09/16/21	DS	P	NRSF	BVL		68 WILSON DR	D R HORTON INC	21688	A
Final Closing Plumbi	09/16/21	DS	P	NRSF	BVL		68 WILSON DR	D R HORTON INC	21689	A
Final Closing Mechan	09/16/21	DS	P	NRSF	BVL		68 WILSON DR	D R HORTON INC	21690	A
Final Closing Gas	09/16/21	DS	P	NRSF	BVL		68 WILSON DR	D R HORTON INC	21691	A
Electric Service	09/16/21	DS	P	ELEC RES	BVL	BVL	112 BATTLETOWN DR	CHILDREY ALANNA	21309	A
Final Closing Electr	09/16/21	DS	P	ELEC RES	BVL	BVL	112 BATTLETOWN DR	CHILDREY ALANNA	21310	A
Water Line Ditch	09/16/21	DS	P	NRSF	BVL	CHPL	277 KINSKY LN	EYCHNER DENNIS W & KATH	21670	A
Final Closing Gas	09/20/21	DS	P	NRSF			65 WILSON DR	D R HORTON INC	21676	A
Final Closing Electr	09/20/21	DS	P	NRSF			65 WILSON DR	D R HORTON INC	19051	A
Final Closing Plumbi	09/20/21	DS	P	NRSF			65 WILSON DR	D R HORTON INC	19054	A
Final Closing Mechan	09/20/21	DS	P	NRSF			65 WILSON DR	D R HORTON INC	19056	A
Final Closing Buildi	09/20/21	DS	P	NRSF			65 WILSON DR	D R HORTON INC	19057	A
Final Closing Buildi	09/20/21	DS	P	NRSF	BVL		68 WILSON DR	D R HORTON INC	21809	A
Electrical Rough In	09/20/21	DS	P	Garage	BVL	BLTN	117 BELL LN	STALEY GERALD C & MARGA	21766	A
Framing	09/20/21	DS	P	Add Res	BVL	BLTN	300 SPRING HOUSE LN	SULLIVAN TIMOTHY PATRIC	19184	A
Electric Service	09/20/21	DS	F	NRSF	BYC	GNWY	3080 MILLWOOD RD	LIONS GATE FARM LLC	18510	A
Final Closing Electr	09/21/21	DS	P	NRSF			57 WILSON DR	D R HORTON INC	19263	A
Final Closing Plumbi	09/21/21	DS	P	NRSF			57 WILSON DR	D R HORTON INC	19266	A

10/01/2021 08:42
2600mshayeb

Clarke County
INSPECTION REPORT

P 3
piinhrpt

Building Inspections

INSPECTIONS PERFORMED: 09/01/21 to 09/30/21

INSPECTION	DATE	BY	RSLT	PROJECT	CITY	AREA	LOCATION	OWNER	INSP ID	T
Final Closing Mechan	09/21/21	DS	P	NRSF			57 WILSON DR	D R HORTON INC	19268	A
Final Closing Buildi	09/21/21	DS	P	NRSF			57 WILSON DR	D R HORTON INC	19269	A
Final Closing Gas	09/21/21	DS	P	NRSF			57 WILSON DR	D R HORTON INC	21677	A
Final Closing Gas	09/21/21	DS	P	NRSF			61 WILSON DR	D R HORTON INC	21678	A
Final Closing Electr	09/21/21	DS	P	NRSF			61 WILSON DR	D R HORTON INC	19063	A
Final Closing Plumbi	09/21/21	DS	P	NRSF			61 WILSON DR	D R HORTON INC	19066	A
Final Closing Mechan	09/21/21	DS	P	NRSF			61 WILSON DR	D R HORTON INC	19068	A
Final Closing Buildi	09/21/21	DS	P	NRSF			61 WILSON DR	D R HORTON INC	19069	A
Plumbing Groundworks	09/21/21	DS	P	NRSF			620 WEEKS CT	D R HORTON INC	21414	A
Sewer Line	09/21/21	DS	P	NRSF			620 WEEKS CT	D R HORTON INC	21760	A
Water Line	09/21/21	DS	P	NRSF			620 WEEKS CT	D R HORTON INC	21761	A
Plumbing Groundworks	09/21/21	DS	P	NRSF			624 WEEKS CT	D R HORTON INC	21402	A
Sewer Line	09/21/21	DS	P	NRSF			624 WEEKS CT	D R HORTON INC	21758	A
Water Line	09/21/21	DS	P	NRSF			624 WEEKS CT	D R HORTON INC	21759	A
Framing	09/21/21	DS	F	Deck/Porch	BVL	BVL	713 MCGUIRE CIR	JUDY GARRY CHRISTOPHER	20592	A
Electrical Rough In	09/21/21	DS	P	Deck/Porch	BVL	BVL	713 MCGUIRE CIR	JUDY GARRY CHRISTOPHER	21753	A
Gas Rough In	09/22/21	DS	P	NRSF			538 WEEKS CT	D R HORTON INC	21765	A
Framing	09/22/21	DS	P	NRSF			538 WEEKS CT	D R HORTON INC	20016	A
Electrical Rough In	09/22/21	DS	P	NRSF			538 WEEKS CT	D R HORTON INC	20018	A
Electric Service	09/22/21	DS	P	NRSF			538 WEEKS CT	D R HORTON INC	20019	A
Plumbing Rough In	09/22/21	DS	P	NRSF			538 WEEKS CT	D R HORTON INC	20022	A
Mechanical Rough In	09/22/21	DS	P	NRSF			538 WEEKS CT	D R HORTON INC	20024	A
Final Closing Plumbi	09/22/21	DS	P	Rmdl Res	BVL	BLTN	443 POSSUM HOLLOW LN	SLACK TIMOTHY E & TEXAN	21773	A
Final Closing Buildi	09/22/21	DS	P	Rmdl Res	BVL	BLTN	443 POSSUM HOLLOW LN	SLACK TIMOTHY E & TEXAN	21774	A
Electric Service	09/22/21	DS	P	ELEC RES	BLMT	CHPL	518 FELTNER RD	SPEARS ELLEN W	21477	A
Final Closing Electr	09/22/21	DS	P	ELEC RES	BLMT	CHPL	518 FELTNER RD	SPEARS ELLEN W	21478	A
Electric Service	09/22/21	DS	P	NRSF	BYC	GNWY	3080 MILLWOOD RD	LIONS GATE FARM LLC	21832	A
Gas Rough In	09/23/21	DS	P	NRSF			534 WEEKS CT	D R HORTON INC	21764	A
Framing	09/23/21	DS	P	NRSF			534 WEEKS CT	D R HORTON INC	20004	A
Electrical Rough In	09/23/21	DS	P	NRSF			534 WEEKS CT	D R HORTON INC	20006	A
Electric Service	09/23/21	DS	P	NRSF			534 WEEKS CT	D R HORTON INC	20007	A
Plumbing Rough In	09/23/21	DS	P	NRSF			534 WEEKS CT	D R HORTON INC	20010	A
Mechanical Rough In	09/23/21	DS	P	NRSF			534 WEEKS CT	D R HORTON INC	20012	A
Electric Service	09/23/21	DS	P	Garage	WHPT	GNWY	104 VISTA LN	SMITH LESLIE CHRISTOPHE	21833	A
Insulation	09/24/21	DS	P	NRSF			538 WEEKS CT	D R HORTON INC	20017	A
Water Line	09/24/21	DS	P	NRSF			85 WHITE POST RD	SELECT PROPERTY MGMT IV	21834	A
Electrical Rough In	09/24/21	DS	F	ELEC RES	BVL	BVL	114 EAST MAIN ST	MCINTYRE GLENN C & JANE	21800	A
Electric Service	09/24/21	DS	F	ELEC RES	BVL	BVL	114 EAST MAIN ST	MCINTYRE GLENN C & JANE	21801	A
Final Closing Buildi	09/24/21	DS	F	Add Res	BVL	BVL	305 SOUTH CHURCH ST	BUTLER KENNETH J & PENE	10896	A
Final Closing Electr	09/27/21	DS	P	NRSF			53 WILSON DR	D R HORTON INC	19275	A
Final Closing Plumbi	09/27/21	DS	P	NRSF			53 WILSON DR	D R HORTON INC	19278	A
Final Closing Mechan	09/27/21	DS	P	NRSF			53 WILSON DR	D R HORTON INC	19280	A
Final Closing Buildi	09/27/21	DS	P	NRSF			53 WILSON DR	D R HORTON INC	19281	A
Final Closing Gas	09/27/21	DS	P	NRSF			53 WILSON DR	D R HORTON INC	21679	A
Insulation	09/27/21	DS	P	NRSF			534 WEEKS CT	D R HORTON INC	20005	A
Bonding Pool	09/27/21	DS	P	SPIG	BVL	BVL	116 HERMITAGE BLVD	ROHRBACH SCOTT	21885	A
Electric Service	09/27/21	DS	P	NRSF	BVL	LNGM	235 CATHER RD	CONDREY JOSEPH B & ALYS	20396	A
Gas Rough In	09/28/21	DS	P	NRSF	BVL		135 DOLEMAN LN	WARFIELD HOMES INC	21958	A
Electric Service	09/28/21	DS	P	ELEC RES	BLMT	BLTN	1767 HARRY BYRD HWY	RICHARDSON RENWICK WARR	21751	A
Final Closing Electr	09/28/21	DS	P	ELEC RES	BLMT	BLTN	1767 HARRY BYRD HWY	RICHARDSON RENWICK WARR	21752	A
Final Closing Gas	09/28/21	DS	P	Gas Per-R	BVL	BVL	206 STAYMAN DR	MCCLAFFERTY JOHN C & LE	21728	A
Final Closing Buildi	09/28/21	DS	P	Deck/Porch	BVL	BVL	309 HERMITAGE BLVD	HILLIARD JOHN & TISHA	21497	A

10/01/2021 08:42
2600mshayeb

Clarke County
INSPECTION REPORT

P 4
piinhrpt

Building Inspections

INSPECTIONS PERFORMED: 09/01/21 to 09/30/21

INSPECTION	DATE	BY	RSLT	PROJECT	CITY	AREA	LOCATION	OWNER	INSP ID	T
Framing	09/28/21	DS	F	Deck/Porch	BVL	BVL	406 BLOSSOM DR	HERNANDEZ MARIA D & EDW	21519	A
Footings	09/28/21	DS	P	NRSF	BVL	LNGM	54 VILLAGE LN	TAPSCOTT MARGARET E	19677	A
Framing	09/29/21	DS	P	NRSF			50 WILSON DR	D R HORTON INC	19538	A
Electrical Rough In	09/29/21	DS	P	NRSF			50 WILSON DR	D R HORTON INC	19540	A
Electric Service	09/29/21	DS	P	NRSF			50 WILSON DR	D R HORTON INC	19541	A
Plumbing Rough In	09/29/21	DS	P	NRSF			50 WILSON DR	D R HORTON INC	19544	A
Mechanical Rough In	09/29/21	DS	P	NRSF			50 WILSON DR	D R HORTON INC	19546	A
Gas Rough In	09/29/21	DS	P	NRSF			50 WILSON DR	D R HORTON INC	21828	A
Final Closing Electr	09/29/21	DS	P	NRSF	BVL		60 WILSON DR	D R HORTON INC	19075	A
Final Closing Plumbi	09/29/21	DS	P	NRSF	BVL		60 WILSON DR	D R HORTON INC	19078	A
Final Closing Mechan	09/29/21	DS	P	NRSF	BVL		60 WILSON DR	D R HORTON INC	19080	A
Final Closing Buildi	09/29/21	DS	F	NRSF	BVL		60 WILSON DR	D R HORTON INC	19081	A
Final Closing Gas	09/29/21	DS	P	NRSF	BVL		60 WILSON DR	D R HORTON INC	21680	A
Electric Service	09/29/21	DS	P	NRSF	BVL	BLTN	1609 SPRINGSBURY RD	WENCE LUKE TAYLOR & CHR	19221	A
Gas Line	09/29/21	DS	P	Add Res	BVL	BLTN	300 SPRING HOUSE LN	SULLIVAN TIMOTHY PATRIC	21974	A
Ditch Electric	09/29/21	DS	P	Add Res	BVL	BLTN	300 SPRING HOUSE LN	SULLIVAN TIMOTHY PATRIC	22016	A
Framing	09/29/21	DS	P	Accessory	BLMT	BLTN	56 VALLEY SPRINGS LN	WEARE WILLIAM B & CAROL	20152	A
Gas Tank	09/30/21	DS	P	NRSF	BVL		1150 LEWISVILLE RD	WARFIELD HOMES INC	22006	A
Gas Line	09/30/21	DS	P	NRSF	BVL		1150 LEWISVILLE RD	WARFIELD HOMES INC	22007	A
Sewer Line	09/30/21	DS	P	NRSF			41 WILSON DR	D R HORTON INC	21961	A
Water Line	09/30/21	DS	P	NRSF			41 WILSON DR	D R HORTON INC	21962	A
Plumbing Groundworks	09/30/21	DS	P	NRSF			41 WILSON DR	D R HORTON INC	21630	A
Framing	09/30/21	DS	P	NRSF			44 WILSON DR	D R HORTON INC	19550	A
Electrical Rough In	09/30/21	DS	P	NRSF			44 WILSON DR	D R HORTON INC	19552	A
Electric Service	09/30/21	DS	P	NRSF			44 WILSON DR	D R HORTON INC	19553	A
Plumbing Rough In	09/30/21	DS	P	NRSF			44 WILSON DR	D R HORTON INC	19556	A
Mechanical Rough In	09/30/21	DS	P	NRSF			44 WILSON DR	D R HORTON INC	19558	A
Gas Rough In	09/30/21	DS	P	NRSF			44 WILSON DR	D R HORTON INC	21829	A
Sewer Line	09/30/21	DS	P	NRSF			49 WILSON DR	D R HORTON INC	21959	A
Water Line	09/30/21	DS	P	NRSF			49 WILSON DR	D R HORTON INC	21960	A
Plumbing Groundworks	09/30/21	DS	P	NRSF			49 WILSON DR	D R HORTON INC	21543	A
Electric Service	09/30/21	DS	P	ELEC RES	BVL	BVL	209 CROWN ST	HENDERSON KRISTIN & RYA	21843	A
Final Closing Electr	09/30/21	DS	P	ELEC RES	BVL	BVL	209 CROWN ST	HENDERSON KRISTIN & RYA	21844	A
INSPECTOR TOTALS: 189 INSPECTIONS FEES: .00 PAID TO DATE: .00 UNPAID: .00										
Framing	09/01/21	JR	P	NRSF	BLMT		180 CEDAR LN	HACKBERRY LLC 2020	21425	A
Electric Service	09/01/21	JR	P	NRSF	BLMT		180 CEDAR LN	HACKBERRY LLC 2020	21426	A
Electrical Rough In	09/01/21	JR	P	NRSF	BLMT		180 CEDAR LN	HACKBERRY LLC 2020	21427	A
Insulation	09/01/21	JR	P	NRSF	BLMT		180 CEDAR LN	HACKBERRY LLC 2020	20333	A
Final Closing Buildi	09/01/21	JR	P	Add Res	BVL	LNGM	1245 MOOSE RD	LANHAM JAMES B & CATHER	21369	A
Final Closing Buildi	09/01/21	JR	P	SPAG	BVL	LNGM	829 CASTLEROCK LN	MOONEY KEVIN M & JENNIF	20410	A
Framing	09/02/21	JR	F	Rmdl Res	BLMT	BLTN	454 PINE GROVE RD	MELLEN GROUP LLC	20389	A
Electrical Rough In	09/02/21	JR	F	Rmdl Res	BLMT	BLTN	454 PINE GROVE RD	MELLEN GROUP LLC	21108	A
Plumbing Rough In	09/02/21	JR	P	Rmdl Res	BLMT	BLTN	454 PINE GROVE RD	MELLEN GROUP LLC	21109	A
Mechanical Rough In	09/02/21	JR	F	Rmdl Res	BLMT	BLTN	454 PINE GROVE RD	MELLEN GROUP LLC	21479	A
Shower Pan	09/02/21	JR	P	Rmdl Res	BLMT	BLTN	454 PINE GROVE RD	MELLEN GROUP LLC	21480	A
Final Closing Gas	09/02/21	JR	P	NRSF	BVL	CHPL	244 JANEVILLE RD	HERNDON DAVID A &	21430	A
Final Closing Electr	09/02/21	JR	P	NRSF	BVL	CHPL	244 JANEVILLE RD	HERNDON DAVID A &	18260	A
Final Closing Plumbi	09/02/21	JR	P	NRSF	BVL	CHPL	244 JANEVILLE RD	HERNDON DAVID A &	18263	A
Final Closing Mechan	09/02/21	JR	P	NRSF	BVL	CHPL	244 JANEVILLE RD	HERNDON DAVID A &	18265	A
Final Closing Buildi	09/02/21	JR	P	NRSF	BVL	CHPL	244 JANEVILLE RD	HERNDON DAVID A &	18266	A

10/01/2021 08:42
2600mshayeb

Clarke County
INSPECTION REPORT

P 5
piinhrpt

Building Inspections

INSPECTIONS PERFORMED: 09/01/21 to 09/30/21

INSPECTION	DATE	BY	RSLT	PROJECT	CITY	AREA	LOCATION	OWNER	INSP ID	T
Electric Service	09/02/21	JR	P	Solar	BVL	LNGM	85 FISHPAW RD	FRAPPOLLO PAUL M	21249	A
Final Closing Mechan	09/03/21	JR	P	MechPer-R	BVL	BLTN	5973 LORD FAIRFAX HWY	WOOD IRIS H	21446	A
Electrical Rough In	09/03/21	JR	P	ELEC RES	BVL	BLTN	96 FRANKFORD LN	FRANKFORD FARM MANAGEME	21311	A
Final Closing Electr	09/03/21	JR	P	Add Comm	BVL	BVL	450 MOSBY BLVD	BERRYVILLE AL LLC	21450	A
Final Closing Plumbi	09/03/21	JR	F	Add Comm	BVL	BVL	450 MOSBY BLVD	BERRYVILLE AL LLC	21451	A
Sprinkler System	09/03/21	JR	F	Add Comm	BVL	BVL	450 MOSBY BLVD	BERRYVILLE AL LLC	21452	A
Final Closing Mechan	09/03/21	JR	F	Add Comm	BVL	BVL	450 MOSBY BLVD	BERRYVILLE AL LLC	21453	A
Final Closing Buildi	09/03/21	JR	F	Add Comm	BVL	BVL	450 MOSBY BLVD	BERRYVILLE AL LLC	21454	A
Fire Alarm System	09/03/21	JR	P	Add Comm	BVL	BVL	450 MOSBY BLVD	BERRYVILLE AL LLC	21455	A
Final Closing Electr	09/03/21	JR	P	Solar	BVL	LNGM	85 FISHPAW RD	FRAPPOLLO PAUL M	18936	A
Final Closing Buildi	09/03/21	JR	P	Solar	BVL	LNGM	85 FISHPAW RD	FRAPPOLLO PAUL M	18937	A
Electric Service	09/03/21	JR	P	ELEC RES	BVL	LNGM	859 MOOSE RD	CHASLER THOMAS	21461	A
Final Closing Electr	09/03/21	JR	P	ELEC RES	BVL	LNGM	859 MOOSE RD	CHASLER THOMAS	21462	A
Gas Rough In	09/08/21	JR	P	NRSF			512 HARPER DR	D R HORTON INC	21466	A
Framing	09/08/21	JR	P	NRSF			512 HARPER DR	D R HORTON INC	19727	A
Electrical Rough In	09/08/21	JR	P	NRSF			512 HARPER DR	D R HORTON INC	19729	A
Electric Service	09/08/21	JR	P	NRSF			512 HARPER DR	D R HORTON INC	19730	A
Plumbing Rough In	09/08/21	JR	P	NRSF			512 HARPER DR	D R HORTON INC	19733	A
Mechanical Rough In	09/08/21	JR	P	NRSF			512 HARPER DR	D R HORTON INC	19735	A
Framing	09/08/21	JR	P	NRSF			517 HARPER DR	D R HORTON INC	20028	A
Electrical Rough In	09/08/21	JR	P	NRSF			517 HARPER DR	D R HORTON INC	20030	A
Electric Service	09/08/21	JR	P	NRSF			517 HARPER DR	D R HORTON INC	20031	A
Plumbing Rough In	09/08/21	JR	P	NRSF			517 HARPER DR	D R HORTON INC	20034	A
Mechanical Rough In	09/08/21	JR	P	NRSF			517 HARPER DR	D R HORTON INC	20036	A
Gas Rough In	09/08/21	JR	P	NRSF			517 HARPER DR	D R HORTON INC	21467	A
Sewer Line	09/08/21	JR	P	NRSF			609 WEEKS CT	D R HORTON INC	21508	A
Water Line	09/08/21	JR	P	NRSF			609 WEEKS CT	D R HORTON INC	21509	A
Plumbing Groundworks	09/08/21	JR	P	NRSF			609 WEEKS CT	D R HORTON INC	21028	A
Plumbing Groundworks	09/08/21	JR	P	NRSF			613 WEEKS CT	D R HORTON INC	21016	A
Sewer Line	09/08/21	JR	P	NRSF			613 WEEKS CT	D R HORTON INC	21510	A
Water Line	09/08/21	JR	P	NRSF			613 WEEKS CT	D R HORTON INC	21511	A
Footings	09/08/21	JR	P	NRSF	BYC		86 VICTORY LN	HURTADO PEDRO	21550	A
Final Closing Electr	09/08/21	JR	P	Accessory	BVL	BVL	209 RICE ST	HAYDEN ANNA MAE TRSTEE	21504	A
Final Closing Buildi	09/08/21	JR	P	Accessory	BVL	BVL	209 RICE ST	HAYDEN ANNA MAE TRSTEE	21218	A
Meeting with Inspect	09/08/21	JR	p	Deck/Porch	BVL	BVL	433 PAGE ST	SCHOONOVER ALAN C & SUS	21587	A
Insulation	09/09/21	JR	P	NRSF			504 HARPER DR	D R HORTON INC	19773	A
Framing	09/09/21	JR	F	NRSF			505 HARPER DR	D R HORTON INC	19562	A
Electrical Rough In	09/09/21	JR	P	NRSF			505 HARPER DR	D R HORTON INC	19564	A
Electric Service	09/09/21	JR	P	NRSF			505 HARPER DR	D R HORTON INC	19565	A
Plumbing Rough In	09/09/21	JR	P	NRSF			505 HARPER DR	D R HORTON INC	19568	A
Mechanical Rough In	09/09/21	JR	P	NRSF			505 HARPER DR	D R HORTON INC	19570	A
Gas Rough In	09/09/21	JR	P	NRSF			505 HARPER DR	D R HORTON INC	21468	A
Insulation	09/09/21	JR	F	NRSF			508 HARPER DR	D R HORTON INC	19745	A
Backfill	09/09/21	JR	P	NRSF			85 WHITE POST RD	SELECT PROPERTY MGMT IV	21512	A
DrainTile	09/09/21	JR	P	NRSF			85 WHITE POST RD	SELECT PROPERTY MGMT IV	21513	A
Gas Line Pressure Te	09/09/21	JR	P	Add Res	BVL	BLTN	300 SPRING HOUSE LN	SULLIVAN TIMOTHY PATRIC	21490	A
Plumbing Rough In	09/09/21	JR	P	Rmdl Res	BLMT	CHPL	4822 EBENEZER RD	COUNTY OF CLARKE	21549	A
Framing	09/10/21	JR	PWC	Rmdl Res	BLMT	BLTN	454 PINE GROVE RD	MELLEN GROUP LLC	21501	A
Electrical Rough In	09/10/21	JR	PWC	Rmdl Res	BLMT	BLTN	454 PINE GROVE RD	MELLEN GROUP LLC	21502	A
Mechanical Rough In	09/10/21	JR	PWC	Rmdl Res	BLMT	BLTN	454 PINE GROVE RD	MELLEN GROUP LLC	21503	A
Footings	09/10/21	JR	P	Garage	BVL	BLTN	5540 HARRY BYRD HWY	CAMACHO-PEREZ GUALBERTO	21521	A
Grounding	09/10/21	JR	P	Garage	BVL	BLTN	5540 HARRY BYRD HWY	CAMACHO-PEREZ GUALBERTO	21582	A

10/01/2021 08:42
2600mshayeb

Clarke County
INSPECTION REPORT

P 6
piinhprt

Building Inspections

INSPECTIONS PERFORMED: 09/01/21 to 09/30/21

INSPECTION	DATE	BY	RSLT	PROJECT	CITY	AREA	LOCATION	OWNER	INSP ID	T
Electric Service	09/10/21	JR	F	ELEC RES	BVL	CHPL	5154 SENSENY RD	FFC PROPERTIES LLC	21283	A
Final Closing Electr	09/10/21	JR	F	ELEC RES	BVL	CHPL	5154 SENSENY RD	FFC PROPERTIES LLC	21284	A
Framing	09/10/21	JR	PWC	Rmdl Res	BVL	LNGM	1274 TRIPLE J RD	HATLEY NOLAN E & GILLIA	20721	A
Electrical Rough In	09/10/21	JR	PWC	Rmdl Res	BVL	LNGM	1274 TRIPLE J RD	HATLEY NOLAN E & GILLIA	21581	A
Plumbing Groundworks	09/13/21	JR	P	NRSF	BVL		1038 WESTWOOD RD	SIMS AARON WAYNE & REBE	21578	A
Slab Basement	09/13/21	JR	P	NRSF	BVL		1038 WESTWOOD RD	SIMS AARON WAYNE & REBE	21579	A
Backfill	09/13/21	JR	P	NRSF	BVL		1038 WESTWOOD RD	SIMS AARON WAYNE & REBE	21580	A
Framing	09/13/21	JR	P	NRSF			505 HARPER DR	D R HORTON INC	21597	A
Insulation	09/13/21	JR	P	NRSF			517 HARPER DR	D R HORTON INC	21470	A
Ditch Electric	09/13/21	JR	F	SPIG	BVL	BVL	116 HERMITAGE BLVD	ROHRBACH SCOTT	21589	A
Footings	09/13/21	JR	P	Deck/Porch	BVL	BVL	406 BLOSSOM DR	HERNANDEZ MARIA D & EDW	21518	A
Final Closing Buildi	09/13/21	JR	P	Add Comm	BVL	BVL	450 MOSBY BLVD	BERRYVILLE AL LLC	21586	A
Final Closing Plumbi	09/13/21	JR	P	Add Comm	BVL	BVL	450 MOSBY BLVD	BERRYVILLE AL LLC	21682	A
Sprinkler System	09/13/21	JR	P	Add Comm	BVL	BVL	450 MOSBY BLVD	BERRYVILLE AL LLC	21683	A
Final Closing Mechan	09/13/21	JR	P	Add Comm	BVL	BVL	450 MOSBY BLVD	BERRYVILLE AL LLC	21684	A
Final Closing Buildi	09/13/21	JR	P	Garage	BLMT	CHPL	1953 MORGANS MILL RD	STEWART DAVID W & E HOP	21583	A
Insulation	09/13/21	JR	P	Rmdl Res	BVL	LNGM	1274 TRIPLE J RD	HATLEY NOLAN E & GILLIA	20722	A
Framing	09/13/21	JR	F	NRSF	BVL	LNGM	135 DOLEMAN LN	WARFIELD HOMES INC	19992	A
Plumbing Rough In	09/13/21	JR	F	NRSF	BVL	LNGM	135 DOLEMAN LN	WARFIELD HOMES INC	19998	A
Mechanical Rough In	09/13/21	JR	P	NRSF	BVL	LNGM	135 DOLEMAN LN	WARFIELD HOMES INC	20000	A
Electrical Rough In	09/13/21	JR	P	NRSF	BVL	LNGM	135 DOLEMAN LN	WARFIELD HOMES INC	19994	A
Footings	09/14/21	JR	F	NRSF	BLMT		11 ASPEN LN	BLUEMONT BUILDERS LLC	20731	A
DrainTile	09/14/21	JR	F	NRSF	BLMT		11 ASPEN LN	BLUEMONT BUILDERS LLC	21990	A
Final Closing Buildi	09/14/21	JR	F	NRSF	BVL		68 WILSON DR	D R HORTON INC	21608	A
Footings	09/14/21	JR	P	NRSF	BLMT		77 BALSAM LN	ALOHA 318 ESTATES LLC	20743	A
DrainTile	09/14/21	JR	P	NRSF	BLMT		77 BALSAM LN	ALOHA 318 ESTATES LLC	21991	A
Framing	09/14/21	JR	P	Deck/Porch	BVL	BVL	249 TYSON DR	PLATENBERG JANET ALEXAN	21499	A
Framing	09/14/21	JR	P	Rmdl Res	BLMT	CHPL	473 LEEDS MANOR LN	WILSON JOSEPH R & PAULA	21232	A
Electrical Rough In	09/14/21	JR	P	Rmdl Res	BLMT	CHPL	473 LEEDS MANOR LN	WILSON JOSEPH R & PAULA	21595	A
Electric Service	09/14/21	JR	P	ELEC RES	BVL	CHPL	5154 SENSENY RD	FFC PROPERTIES LLC	21685	A
Final Closing Electr	09/14/21	JR	P	ELEC RES	BVL	CHPL	5154 SENSENY RD	FFC PROPERTIES LLC	21686	A
Final Closing Buildi	09/14/21	JR	P	Accessory	BVL	LNGM	1400 RUSSELL RD	RICHARDSON AMES B & APR	21494	A
Insulation	09/16/21	JR	P	Rmdl Res	BLMT	BLTN	454 PINE GROVE RD	MELLEN GROUP LLC	20390	A
Insulation	09/16/21	JR	P	Add Res	BVL	BVL	116 HERMITAGE BLVD	ROHRBACH SCOTT	20082	A
Ditch Electric	09/16/21	JR	P	SPIG	BVL	BVL	116 HERMITAGE BLVD	ROHRBACH SCOTT	21669	A
Final Closing Gas	09/16/21	JR	P	Gas Per-C	BVL	CHPL	3449 LOCKES MILL RD	MILLER JOHN U JR	19876	A
Insulation	09/16/21	JR	P	Rmdl Res	WHPT	GNWY	179 BERRYS FERRY RD	KEMPSON KENNETH & CATHA	18362	A
Final Closing Electr	09/16/21	JR	P	Elec Per-C	BVL	LNGM	890 WEST MAIN ST	RURITAN CLUB OF CLARKE	21517	A
Gas Line	09/17/21	JR	P	Gas Per-R	BVL		26 PULLIAM CT	GIVENS LINDA MILAGRO	21592	A
Gas Line Pressure Te	09/17/21	JR	P	Gas Per-R	BVL		26 PULLIAM CT	GIVENS LINDA MILAGRO	21593	A
Final Closing Gas	09/17/21	JR	P	Gas Per-R	BLMT	BLTN	17641 RAVEN ROCKS RD	RUTTER PHILLIP W & JANE	21366	A
Framing	09/17/21	JR	P	Deck/Porch	BLMT	BLTN	346 DOGWOOD LN	WINE EARL M JR & SHARON	21736	A
Final Closing Buildi	09/17/21	JR	F	Garage	PRS	CHPL	112 STONE RIDGE LN	DOHERTY OWEN	21720	A
Final Closing Mechan	09/17/21	JR	P	MechPer-R	BVL	CHPL	340 BRIGGS RD	DETWILER DANIEL L III &	21600	A
Footings	09/21/21	JR	P	Deck/Porch	BVL	BVL	309 HERMITAGE BLVD	HILLIARD JOHN & TISHA	21495	A
Framing	09/21/21	JR	P	Deck/Porch	BVL	BVL	309 HERMITAGE BLVD	HILLIARD JOHN & TISHA	21496	A
Final Closing Electr	09/21/21	JR	F	Solar	BVL	LNGM	12173 HARRY BYRD HWY	BALLOUE ERIN E	20281	A
Final Closing Buildi	09/21/21	JR	F	Solar	BVL	LNGM	12173 HARRY BYRD HWY	BALLOUE ERIN E	20282	A
Plumbing Rough In	09/22/21	JR	PWC	NRSF	BVL		135 DOLEMAN LN	WARFIELD HOMES INC	21807	A
Framing	09/22/21	JR	P	NRSF	BVL		135 DOLEMAN LN	WARFIELD HOMES INC	21808	A
Framing	09/22/21	JR	P	Garage	BVL	BLTN	117 BELL LN	STALEY GERALD C & MARGA	19712	A
Plumbing Rough In	09/22/21	JR	F	Rmdl Res	BVL	BVL	20 JOSEPHINE ST	SCHOOLING, SCOTT	21831	A

10/01/2021 08:42
2600mshayeb

Clarke County
INSPECTION REPORT

P 7
piinhrpt

Building Inspections

INSPECTIONS PERFORMED: 09/01/21 to 09/30/21

INSPECTION	DATE	BY	RSLT	PROJECT	CITY	AREA	LOCATION	OWNER	INSP ID	T
Meeting with Inspect	09/22/21	JR	P	Deck/Porch	BVL	BVL	713 MCGUIRE CIR	JUDY GARRY CHRISTOPHER	21827	A
Insulation	09/22/21	JR	P	NRSF	BVL	LNGM	135 DOLEMAN LN	WARFIELD HOMES INC	19993	A
Electric Service	09/23/21	JR	P	Elec Per-C	BLMT	BLTN	1162 PINE GROVE RD	WINK JAMES & TRACEE M	21840	A
Final Closing Electr	09/23/21	JR	P	Elec Per-C	BLMT	BLTN	1162 PINE GROVE RD	WINK JAMES & TRACEE M	21841	A
Final Closing Gas	09/23/21	JR	P	Gas Per-R	BVL	LNGM	2722 CRUMS CHURCH RD	JOHNSON PATRICK M & JOA	21125	A
Footings	09/24/21	JR	P	Accessory	BLMT	BLTN	56 VALLEY SPRINGS LN	WEARE WILLIAM B & CAROL	20151	A
Framing	09/24/21	JR	P	Garage	PRS	CHPL	21860 BLUE RIDGE MTN RD	TAYLOR GREG L & DESTA B	19335	A
Final Closing Electr	09/24/21	JR	F	NRSF	BVL	LNGM	138 KAVE LN	DAVIS SAMUEL LEWIS	12005	A
Final Closing Plumbi	09/24/21	JR	F	NRSF	BVL	LNGM	138 KAVE LN	DAVIS SAMUEL LEWIS	12008	A
Final Closing Mechan	09/24/21	JR	F	NRSF	BVL	LNGM	138 KAVE LN	DAVIS SAMUEL LEWIS	12010	A
Final Closing Buildi	09/24/21	JR	F	NRSF	BVL	LNGM	138 KAVE LN	DAVIS SAMUEL LEWIS	12011	A
Final Closing Gas	09/24/21	JR	F	NRSF	BVL	LNGM	138 KAVE LN	DAVIS SAMUEL LEWIS	21830	A
Electric Service	09/27/21	JR	P	ELEC RES	BLMT	BLTN	178 GOOD SHEPHERD RD	SMALLWOOD 3RD WILLIAM D	21482	A
Final Closing Electr	09/27/21	JR	P	ELEC RES	BLMT	BLTN	178 GOOD SHEPHERD RD	SMALLWOOD 3RD WILLIAM D	21483	A
Framing	09/27/21	JR	P	Rmdl Res	BYC	GNWY	965 RED GATE RD	GREENHALGH LANGDON B &	21269	A
Electrical Rough In	09/27/21	JR	P	Rmdl Res	BYC	GNWY	965 RED GATE RD	GREENHALGH LANGDON B &	21849	A
Fire Off Mechanical	09/28/21	JR	P	NRSF			513 HARPER DR	D R HORTON INC	22004	A
Fire Off Mechanical	09/28/21	JR	P	NRSF			517 HARPER DR	D R HORTON INC	22005	A
Final Closing Electr	09/28/21	JR	F	Solar	BVL	BVL	14 BYRD AVE	ROARK WILLIAM MICHAEL &	20054	A
Final Closing Buildi	09/28/21	JR	F	Solar	BVL	BVL	14 BYRD AVE	ROARK WILLIAM MICHAEL &	20055	A
Water Line	09/29/21	JR	P	NRSF	BYC		86 VICTORY LN	HURTADO PEDRO	21998	A
Framing	09/29/21	JR	F	Deck/Porch	BVL	BVL	795 MCGUIRE CIR	BROWN RUSSELL S & JOANN	21220	A
Final Closing Buildi	09/29/21	JR	F	Deck/Porch	BVL	BVL	795 MCGUIRE CIR	BROWN RUSSELL S & JOANN	21221	A
Insulation	09/29/21	JR	P	Rmdl Res	BYC	GNWY	965 RED GATE RD	GREENHALGH LANGDON B &	21270	A
Framing	09/30/21	JR	P	Rmdl Res	BVL	BLTN	1542 CHILLY HOLLOW RD	RUSSELL GORDON D	11121	A
Electrical Rough In	09/30/21	JR	P	Rmdl Res	BVL	BLTN	1542 CHILLY HOLLOW RD	RUSSELL GORDON D	21989	A
Final Closing Electr	09/30/21	JR	P	Rmdl Comm	BVL	BVL	25 WEST MAIN ST	AIRLIE ENTERPRISES L C	21987	A
Final Closing Plumbi	09/30/21	JR	P	Rmdl Comm	BVL	BVL	25 WEST MAIN ST	AIRLIE ENTERPRISES L C	21988	A
Final Closing Buildi	09/30/21	JR	P	Rmdl Comm	BVL	BVL	25 WEST MAIN ST	AIRLIE ENTERPRISES L C	17466	A
Framing	09/30/21	JR	P	Deck/Porch	BVL	BVL	713 MCGUIRE CIR	JUDY GARRY CHRISTOPHER	21997	A
Meeting with Inspect	09/30/21	JR	P	Garage	PRS	CHPL	112 STONE RIDGE LN	DOHERTY OWEN	22049	A
Final Closing Buildi	09/30/21	JR	PWC	Rmdl Res	BYC	GNWY	7117 HOWELLSVILLE RD	CANTRELL LARRY & EVELYN	15826	A
INSPECTOR TOTALS:		152	INSPECTIONS		FEEES:	.00	PAID TO DATE:	.00	UNPAID:	.00
FOUNDATION	09/02/21	RE	P	NRSF	BVL		1038 WESTWOOD RD	SIMS AARON WAYNE & REBE	21554	A
FOUNDATION	09/03/21	RE	P	NRSF			601 WEEKS CT	D R HORTON INC	21553	A
Footings	09/03/21	RE	P	Garage	BVL	CHPL	425 ANNFIELD RD	DULANEY SHANNON C & STE	20297	A
Footings	09/20/21	RE	P	NRSF		CHPL	355 JENKINS LN	HUG EZRA M	20663	A
INSPECTOR TOTALS:		4	INSPECTIONS		FEEES:	.00	PAID TO DATE:	.00	UNPAID:	.00
Footings	09/13/21	SP	P	Deck/Porch	BVL	BVL	249 TYSON DR	PLATENBERG JANET ALEXAN	21498	A
Final Closing Mechan	09/15/21	SP	P	MechPer-R	BVL	BVL	118 NORTH BUCKMARSH ST	MEAGHER SHARON	21603	A
INSPECTOR TOTALS:		2	INSPECTIONS		FEEES:	.00	PAID TO DATE:	.00	UNPAID:	.00
DEPARTMENT TOTALS:		347	INSPECTIONS		FEEES:	.00	PAID TO DATE:	.00	UNPAID:	.00
REPORT TOTALS:		347	INSPECTIONS		FEEES:	.00	PAID TO DATE:	.00	UNPAID:	.00

10/01/2021 08:42
2600mshayeb

Clarke County
INSPECTION REPORT

P 8
piinhrpt

Building Inspections

INSPECTIONS PERFORMED: 09/01/21 to 09/30/21

INSPECTION TYPE SUMMARY	COUNT	INSPECTOR SUMMARY	COUNT	RESULT SUMMARY	COUNT
Backfill	2	Douglas Shaffer	189	FAIL	50
Bonding Pool	2	Jamie Royston	152	PASS	289
Ditch Electric	4	Ruckman Engineering PLC	4	PASS WITH CONDITIONS	8
DrainTile	4	Steven Priputen	2		
Electric Service	28				
Electrical Rough In	22				
Final Closing Building	39				
Final Closing Electric	28				
Final Closing Gas	16				
Final Closing Mechanical	18				
Final Closing Plumbing	17				
Fire Alarm System	1				
Fire Off Mechanical or Gas	3				
Footings	16				
FOUNDATION	2				
Framing	35				
Gas Line	7				
Gas Line Pressure Test	3				
Gas Rough In	10				
Gas Tank	4				
Grounding	1				
Insulation	15				
Mechanical Rough In	12				
Meeting with Inspector	3				
Plumbing Groundworks	10				
Plumbing Rough In	14				
Sewer Line	9				
Shower Pan	2				
Slab	1				
Slab Basement	2				
Slab Garage/Carport	2				
Sprinkler System	2				
Water Line	11				
Water Line Ditch	1				
Waterproofing/Parging	1				

TOTAL INSPECTIONS: 347

10/01/2021 08:42
2600mshayeb

Clarke County
INSPECTION REPORT

P 9
piinhrpt

ALL

INSPECTIONS PERFORMED: 09/01/21 to 09/30/21

INSPECTION TYPE SUMMARY	COUNT	INSPECTOR SUMMARY	COUNT	RESULT SUMMARY	COUNT
Backfill	2	Douglas Shaffer	189	FAIL	50
Bonding Pool	2	Jamie Royston	152	PASS	289
Ditch Electric	4	Ruckman Engineering PLC	4	PASS WITH CONDITIONS	8
DrainTile	4	Steven Priputen	2		
Electric Service	28				
Electrical Rough In	22				
Final Closing Building	39				
Final Closing Electric	28				
Final Closing Gas	16				
Final Closing Mechanical	18				
Final Closing Plumbing	17				
Fire Alarm System	1				
Fire Off Mechanical or Gas	3				
Footings	16				
FOUNDATION	2				
Framing	35				
Gas Line	7				
Gas Line Pressure Test	3				
Gas Rough In	10				
Gas Tank	4				
Grounding	1				
Insulation	15				
Mechanical Rough In	12				
Meeting with Inspector	3				
Plumbing Groundworks	10				
Plumbing Rough In	14				
Sewer Line	9				
Shower Pan	2				
Slab	1				
Slab Basement	2				
Slab Garage/Carport	2				
Sprinkler System	2				
Water Line	11				
Water Line Ditch	1				
Waterproofing/Parging	1				

TOTAL INSPECTIONS: 347

** END OF REPORT - Generated by Michelle Shayeb **

Project Application Report - Building Dept

For Period: 9/1/2021 to 9/30/2021

Project Type	Project Number	Project Fees
Commercial Electric Permit	210368	66.30
	210381	173.40
	210395	204.00
Commercial Handicap Ramp	210405	61.20
Commercial Remodel	210441	406.00
Residential Accessory	210410	379.32
	210418	506.48
Residential Addition	210394	397.90
	210417	673.37
	210426	743.71
Residential Deck/Porch no Roof	210376	51.00
	210378	51.00
	210400	201.00
	210408	201.00
	210427	51.00
Residential Deck/Porch w/Roof	210379	51.00
	210382	51.00
Residential Electric Permit	210373	45.90
	210375	56.10
	210380	45.90
	210391	45.90
	210409	45.90
	210415	193.80
	210421	45.90
	210423	45.90
	210438	45.90
	210442	45.90
	210446	66.30
Residential Garage	210383	542.74
	210416	360.43
	210425	685.66
Residential Gas Permit	210386	40.80
	210389	45.90
	210397	40.80

Project Application Report - Building Dept

For Period: 9/1/2021 to 9/30/2021

Project Type	Project Number	Project Fees
Residential Gas Permit	210402	45.90
	210407	40.80
	210444	40.80
Residential Mechanical Permit	210396	40.80
	210411	40.80
	210440	45.90
Residential New	210384	1211.60
	210385	985.07
	210392	1082.77
	210393	985.07
	210398	1826.35
	210399	2246.57
	210413	1581.74
	210414	1761.72
	210430	5764.92
	210432	1581.74
	210433	1761.72
	210434	1761.72
	210435	1581.74
	210436	1204.84
	210437	1204.84
	210447	1204.84
	210448	1204.84
Residential Plumbing Permit	210404	40.80
Residential Remodel	210371	153.00
	210419	209.10
	210424	715.28
	210439	692.15
Solar Array System	210420	142.80
Tents Over 900 sq ft	210406	40.80
Total		37869.43

Project Application Report - Building Dept

For Period: 9/1/2021 to 9/30/2021

Project Type	Project Number	Location	Owner	Estimated Building Value	Fees <small>Blank = collected by another dept</small>	Project Status
Commercial Electric Permit	210368	102 W MAIN ST	BATTLETOWN ENTERPRISES LLC	\$0	\$66.30	ISSUED W/O CONDITIONS
	210381	890 W MAIN ST	RURITAN CLUB OF CLARKE COUNTY	\$0	\$173.40	ISSUED W/O CONDITIONS
	210395	3449 LOCKES MILL RD	MILLER JOHN U JR	\$0	\$204.00	ISSUED W/O CONDITIONS
Commercial Handicap Ramp	210405	317 W MAIN ST	CLARKE COUNTY PRIMARY SCHOOL	\$0	\$61.20	ISSUED W/O CONDITIONS
Commercial Remodel	210441	210 W MAIN ST	WELLHAUS VENTURES LLC	\$0	\$406.00	ISSUED W/O CONDITIONS
Residential Accessory	210410	97 KENT FARM LN	TURKEL JONATHAN MICHAEL	\$17,280	\$379.32	ISSUED W/O CONDITIONS
	210418	62 ROCKY BANK LN	MEANS IHRIE POU CARR & HOWARD B	\$9,210	\$506.48	ISSUED W/O CONDITIONS
Residential Addition	210394	4028 EBENEZER RD	MERLOS FIDEL	\$8,110	\$397.90	ISSUED W/O CONDITIONS
	210417	113 GARDEN RD	FILIPPINI ALMEIDA CESAR GARBRIEL &	\$48,664	\$673.37	ISSUED W/O CONDITIONS
	210426	4173 EBENEZER RD	SUMMERS LAWRENCE A & JENNIFER	\$41,218	\$743.71	ISSUED W/O CONDITIONS
Residential Deck/Porch no Roof	210376	504 WEEKS CT	ZELMS ANDREW MICHAEL & KELSEY FRANCIS	\$0	\$51.00	ISSUED W/O CONDITIONS
	210378	309 HERMITAGE BLVD	HILLIARD JOHN & TISHA	\$0	\$51.00	ISSUED W/O CONDITIONS
	210400	2025 CALMES NECK LN	SAHKUL SVEN JOHANNES	\$0	\$201.00	ISSUED W/O CONDITIONS
	210408	1691 CALMES NECK LN	RATCLIFFE ROBERT W & JENNIFER A	\$0	\$201.00	ISSUED W/O CONDITIONS
	210427	504 PAGE ST	ALI SYED NISHAT	\$0	\$51.00	ISSUED W/O CONDITIONS
Residential Deck/Porch w/Roof	210379	249 TYSON DR	PLATENBERG JANET ALEXANDER	\$0	\$51.00	ISSUED W/O CONDITIONS

Project Application Report - Building Dept

For Period: 9/1/2021 to 9/30/2021

Project Type	Project Number	Location	Owner	Estimated Building Value	Fees <small>Blank = collected by another dept</small>	Project Status
Residential Deck/Porch w/Roof	210382	406 BLOSSOM DR	HERNANDEZ MARIA D & EDWIN O CASTIL	\$0	\$51.00	ISSUED W/O CONDITIONS
Residential Electric Permit	210373	518 FELTNER RD	SPEARS ELLEN W	\$0	\$45.90	ISSUED W/O CONDITIONS
	210375	474 STONE BRIDGE RD	CONOVER CATHERINE M WARNER	\$0	\$56.10	ISSUED W/O CONDITIONS
	210380	1776 OLD WINCHESTER RD	HILL JIMMY L & ELIZABETH E	\$0	\$45.90	ISSUED W/O CONDITIONS
	210391	397 SHEPHERDS MILL RD	FARLEY CARTER & MICHELLE	\$0	\$45.90	ISSUED W/O CONDITIONS
	210409	1767 HARRY BYRD HWY	RICHARDSON RENWICK WARREN & CARA M	\$0	\$45.90	ISSUED W/O CONDITIONS
	210415	114 E MAIN ST	MCINTYRE GLENN C & JANE E	\$0	\$193.80	ISSUED W/O CONDITIONS
	210421	1585 WADESVILLE RD	CIRCLE HILL FARMS INC	\$0	\$45.90	ISSUED W/O CONDITIONS
	210423	209 CROWN ST	HENDERSON MARGARET H	\$0	\$45.90	ISSUED W/O CONDITIONS
	210438	3269 LORD FAIRFAX HWY	SANTOS CARLOS A & BLANCA Y	\$0	\$45.90	ISSUED W/O CONDITIONS
	210442	207 WILLOW LN	COLE JEAN D	\$0	\$45.90	ISSUED W/O CONDITIONS
210446	1022 EBENEZER RD	SMALLWOOD RONALD L & DOLORES P	\$0	\$66.30	ISSUED W/O CONDITIONS	
Residential Garage	210383	5540 HARRY BYRD HWY	CAMACHO-PEREZ GUALBERTO C	\$41,555	\$542.74	ISSUED W/O CONDITIONS
	210416	116 BANJO LN	THOMSON LUKE JOSEPH	\$24,058	\$360.43	ISSUED W/O CONDITIONS
	210425	3095 BISHOP MEADE RD	MARCUS BRADLEY SCOTT & MARGARET A	\$50,472	\$685.66	ISSUED W/O CONDITIONS
Residential Gas Permit	210386	26 PULLIAM CT	GIVENS LINDA MILAGRO	\$0	\$40.80	ISSUED W/O CONDITIONS

Project Application Report - Building Dept

For Period: 9/1/2021 to 9/30/2021

Project Type	Project Number	Location	Owner	Estimated Building Value	Fees <small>Blank = collected by another dept</small>	Project Status
Residential Gas Permit	210389	260 BOOM RD	KINSEY KENT ROBERT & BARBARA JAYNE	\$0	\$45.90	ISSUED W/O CONDITIONS
	210397	485 RUNNING BEAR LN	MITCHELL MARK	\$0	\$40.80	ISSUED W/O CONDITIONS
	210402	206 STAYMAN DR	MCCLAFFERTY JOHN C & LESLIE	\$0	\$45.90	ISSUED W/O CONDITIONS
	210407	232 HERMITAGE BLVD	MILLER PETER HARRIS & ROCHELLE	\$0	\$40.80	ISSUED W/O CONDITIONS
	210444	228 GOOD SHEPHERD RD	DODGE SUSAN B	\$0	\$40.80	ISSUED W/O CONDITIONS
Residential Mechanical Permit	210396	72 CLARKE LN	ROSE TEDMAX S & JANINE A	\$0	\$40.80	ISSUED W/O CONDITIONS
	210411	1180 QUARRY RD	BLACK CLETUS J & JOHN PAUL	\$0	\$40.80	ISSUED W/O CONDITIONS
	210440	1135 CHILLY HOLLOW RD	WHITE LAURA L & EUGENE V TRS	\$0	\$45.90	ISSUED W/O CONDITIONS
Residential New	210384	45 WILSON DR	D R HORTON INC	\$234,183	\$1,211.60	ISSUED W/O CONDITIONS
	210385	49 WILSON DR	D R HORTON INC	\$184,830	\$985.07	ISSUED W/O CONDITIONS
	210392	41 WILSON DR	D R HORTON INC	\$206,116	\$1,082.77	ISSUED W/O CONDITIONS
	210393	37 WILSON DR	D R HORTON INC	\$184,830	\$985.07	ISSUED W/O CONDITIONS
	210398	2287 SWIMLEY RD	MUMPOWER TROY JAMES	\$229,967	\$1,826.35	ISSUED W/O CONDITIONS
	210399	2247 PARSHALL RD	OLMSTEAD MARK T BECKY J & SETH D	\$321,517	\$2,246.57	ISSUED W/O CONDITIONS
	210413	36 WILSON DR	D R HORTON INC	\$314,824	\$1,581.74	ISSUED W/O CONDITIONS
	210414	26 WILSON DR	D R HORTON INC	\$354,036	\$1,761.72	ISSUED W/O CONDITIONS

Project Application Report - Building Dept

For Period: 9/1/2021 to 9/30/2021

Project Type	Project Number	Location	Owner	Estimated Building Value	Fees <small>Blank = collected by another dept</small>	Project Status
Residential New	210430	375 DOUBLE WOOD LN	DOUBLE WOOD FARM LLC	\$1,012,444	\$5,764.92	ISSUED W/O CONDITIONS
	210432	704 WEEKS CT	D R HORTON INC	\$314,824	\$1,581.74	ISSUED W/O CONDITIONS
	210433	700 WEEKS CT	D R HORTON INC	\$354,036	\$1,761.72	ISSUED W/O CONDITIONS
	210434	712 WEEKS CT	D R HORTON INC	\$354,036	\$1,761.72	ISSUED W/O CONDITIONS
	210435	708 WEEKS CT	D R HORTON INC	\$314,824	\$1,581.74	ISSUED W/O CONDITIONS
	210436	33 WILSON DR	D R HORTON INC	\$232,711	\$1,204.84	ISSUED W/O CONDITIONS
	210437	29 WILSON DR	D R HORTON INC	\$232,711	\$1,204.84	ISSUED W/O CONDITIONS
	210447	22 WILSON DR	D R HORTON INC	\$232,711	\$1,204.84	ISSUED W/O CONDITIONS
	210448	18 WILSON DR	D R HORTON INC	\$232,711	\$1,204.84	ISSUED W/O CONDITIONS
Residential Plumbing Permit	210404	305 HENDERSON CT	KOSIOREK MICHAEL D & BETHANY A	\$0	\$40.80	ISSUED W/O CONDITIONS
Residential Remodel	210371	4822 EBENEZER RD	COUNTY OF CLARKE	\$0	\$153.00	ISSUED W/O CONDITIONS
	210419	50 S GREENWAY AVE	ROSEVILLE FARMS LLC	\$0	\$209.10	ISSUED W/O CONDITIONS
	210424	1328 EBENEZER RD	TOMBERLIN GUY D JR & SANDRA R	\$112,500	\$715.28	ISSUED W/O CONDITIONS
	210439	98 E FAIRFAX ST	PARET CHARLES P	\$75,000	\$692.15	ISSUED W/O CONDITIONS
Solar Array System	210420	210 MINNIEWOOD LN	FIDDLER ROBERT G & JOYCE R TRSTEES	\$0	\$142.80	ISSUED W/O CONDITIONS
Tents Over 900 sq ft	210406	500 HUNTINGDON LN	SCHUTTE C H INC	\$0	\$40.80	ISSUED W/O CONDITIONS

Project Application Report - Building Dept

For Period: 9/1/2021 to 9/30/2021

CLARKE COUNTY CIRCUIT COURT
MONTH END DEEDS OF PARTITION AND CONVEYANCE
LOCAL TAXATION DEPARTMENT
COUNTY
FOR SEPTEMBER, 2021

RECORDED	INSTRUMENT	GRANTOR	(X) GRANTEE/ADDRESS	(X) CONSIDERATION	TYPE	PERCENT
09/01/21	212632	MILLER, DAVID J RECORDED TIME: 10:56 DESCRIPTION 1: CHAPEL DISTRICT DATE OF DEED : 00/00/00 BOOK: 687 NUMBER PAGES : 4	N MILLER, DAVID J N/A N/A, XX. 00000 0000 PAGE: 470 MAP: 12A14	N .00	DG	100%
911						PIN: 10
09/01/21	212637	MORELAND, JEFFREY ALAN RECORDED TIME: 11:25 DESCRIPTION 1: BATTLETOWN DISTRICT DATE OF DEED : 00/00/00 BOOK: 687 NUMBER PAGES : 4	N CORDER, ZACHARIAH W 242 CHERRY LANE BLUEMONT, VA. 20135 PAGE: 536 MAP: 17A12	N 160,000.00	DBS	100%
20666 (2)						PIN: 129,000
09/01/21	212639	JONKERS, VICTORIA RECORDED TIME: 12:55 DESCRIPTION 1: DATE OF DEED : 08/31/21 BOOK: 687 NUMBER PAGES : 2	N PAYNE, DEBORAH 397 PYLETOWN RD BOYCE, VA. 22620 PAGE: 561 MAP:	N 170,000.00	DBS	100%
466 (2)						PIN: 167,000 w/imp.
09/02/21	212644	GERMELMAN, DONNA W RECORDED TIME: 09:00 DESCRIPTION 1: TOWN OF BERRYVILLE DATE OF DEED : 08/25/21 BOOK: 687 NUMBER PAGES : 2	N GERMELMAN, DONNA W; ETAL 228 TREADWELL STREET BERRYVILLE, VA. 22611 PAGE: 583 MAP: 14A1-5-3	N .00	DG	100%
1376 (1)						PIN: 197,900 w/imp.
09/02/21	212650	POWERS, CURTIS RECORDED TIME: 13:00 DESCRIPTION 1: LONGMARSH DISTRICT DATE OF DEED : 08/30/21 BOOK: 687 NUMBER PAGES : 3	N HENRY, ROBERT 239 KIMBLE ROAD BERRYVILLE, VA. 22611 PAGE: 617 MAP: 1A65D	N 475,000.00	DBS	100%
59 (2)						PIN: 325,900 w/imp.
09/02/21	212652	PROJECT HOPE RECORDED TIME: 13:32 DESCRIPTION 1: CHAPEL DISTRICT DATE OF DEED : 08/25/21 BOOK: 687 NUMBER PAGES : 2	N CARTER HALL ESTATE LLC 965 RED GATE ROAD BOYCE, VA. 22620 PAGE: 634 MAP: 30A1S	N 5,750,000.00	DBS	100%
5981						PIN: 5,750,000 w/imp.
09/03/21	212667	BARB, OUANE C RECORDED TIME: 14:01 DESCRIPTION 1: DATE OF DEED : 00/00/00 BOOK: 687 NUMBER PAGES : 3	N RUSSELL, WILLIAM 15 BUSHLAND LN BERRYVILLE, VA. 22611 PAGE: 723 MAP: 13A46D	N 550,000.00	DBS	100%
8460 (2)						PIN: 383,700 w/imp.
09/07/21	212695	✓ D.R. HORTON RECORDED TIME: 13:52 DESCRIPTION 1: FELLOWSHIP SQUARE LOT 19 DATE OF DEED : 00/00/00 BOOK: 687 NUMBER PAGES : 2	N SUAREZ, HECTOR RAMON 42 PULLIAM CT BERRYVILLE, VA. 22611 PAGE: 847 MAP: 14G219	N 413,990.00	DBS	100%
985 (1)						PIN: 366,300 w/imp.

CLARKE COUNTY CIRCUIT COURT
MONTH END DEEDS OF PARTITION AND CONVEYANCE
LOCAL TAXATION DEPARTMENT
COUNTY
FOR SEPTEMBER, 2021

RECORDED	INSTRUMENT	GRANTOR	(X) GRANTEE/ADDRESS	(X) CONSIDERATION	TYPE	PERCENT
09/07/21	212698	GRAVES, STEVEN RECORDED TIME: 15:03 DESCRIPTION 1: BATTLETOWN OISTRICT DATE OF DEED : 00/00/00 BOOK: 687 NUMBER PAGES : 3	N NELSON, JONATHAN FRITZ 61 POSSUM HOLLOW LANE BERRYVILLE, VA. 22611 PAGE: 877 MAP: 14E31	N 522,500.00 PIN:	DBS	100%
<i>2380</i>						<i>370800 w/imp.</i>
09/08/21	212701	BURTNER, JEFFREY RECORDED TIME: 10:45 DESCRIPTION 1: HERMITAGE TOWN OF BERRYVILLE DATE OF DEED : 09/07/21 BOOK: 687 NUMBER PAGES : 2	N VAN HORN, JOHN 650 LINOSAY COURT BERRYVILLE, VA. 22611 PAGE: 908 MAP: 14A84213	N 620,000.00 PIN:	DBS	100%
<i>8658</i>						<i>510,500 w/imp.</i>
09/08/21	212703	GIBSON, ANTHONY D RECORDED TIME: 12:50 DESCRIPTION 1: BATTLETOWN DISTRICT, LOT 1 DATE OF DEED : 09/03/21 BOOK: 687 NUMBER PAGES : 3	N XPRESS BUYERS LLC 22801 SETTLERS TRAIL TERRACE ASHBURN, VA. 20148 PAGE: 932 MAP: 14D-1-1	N 279,700.00 PIN:	DBS	100%
<i>2357</i>						<i>279,700 w/imp.</i>
09/08/21	212705	EMRICK, CLARISSA M RECORDED TIME: 14:04 DESCRIPTION 1: BATTLETOWN DISTRICT DATE OF DEED : 00/00/00 BOOK: 687 NUMBER PAGES : 3	N RAMIREZ, JOSE V 3374 SHEPHERDS MILL RD BERRYVILLE, VA. 22611 PAGE: 959 MAP: 10A50	N 544,500.00 PIN:	DBS	100%
<i>7662</i>						<i>384,200 w/imp.</i>
09/09/21	212713	BANK OF CLARKE COUNTY RECORDED TIME: 13:10 DESCRIPTION 1: DATE OF DEED : 09/07/21 BOOK: 688 NUMBER PAGES : 3	N SHAVIT HELMER LLC N/A N/A, XX. 00000 0000 PAGE: 04 MAP: 14A51A5	N 449,600.00 PIN:	DBS	100%
<i>2154</i>						<i>449,600 w/imp.</i>
09/09/21	212716	✓ D.R. HORTON RECORDED TIME: 13:37 DESCRIPTION 1: FELLOWSHIP SQAURE LOT 26 DATE OF DEED : 00/00/00 BOOK: 688 NUMBER PAGES : 2	N DAVIS, AARON 14 PULLIAM COURT BERRYVILLE, VA. 22611 PAGE: 39 MAP: 14G226	N 398,990.00 PIN:	DBS	100%
<i>9522</i>						<i>365,700 w/imp.</i>
09/09/21	212720	ELGIN, CHARLES RECORDED TIME: 14:34 DESCRIPTION 1: THE BECHN LOT 13A DATE OF DEED : 00/00/00 BOOK: 688 NUMBER PAGES : 2	N WARREN, ROBERT EDWARD 872 BENCH LN BLUEMONT, VA. 20135 PAGE: 74 MAP: 25313	N 775,000.00 PIN:	DBS	100%
<i>7992</i>						<i>561,800 w/imp.</i>
09/10/21	212725	AMBRIOSO, MARJORIE RECORDED TIME: 09:20 DESCRIPTION 1: LOT 16 ROCKCROFT SUBDIVISIONS DATE OF DEED : 08/30/21 BOOK: 688 NUMBER PAGES : 2	N HAMBACH, MARGARET 10 ROCKCROFT DRIVE BERRYVILLE, VA. 22611 PAGE: 111 MAP: 14A2216	N 347,000.00 PIN:	DBS	100%
<i>1766</i>						<i>195,000 w/imp.</i>

CLARKE COUNTY CIRCUIT COURT
MONTH END DEEDS OF PARTITION AND CONVEYANCE
LOCAL TAXATION DEPARTMENT
COUNTY
FOR SEPTEMBER, 2021

RECORDED	INSTRUMENT	GRANTOR	(X) GRANTEE/ADDRESS	(X) CONSIDERATION	TYPE	PERCENT
09/10/21	212728	ALLEN, MELANIE RECORDED TIME: 13:50 DESCRIPTION 1: BATTLETOWN DISTR DATE OF DEED : 09/07/21 BOOK: 688 NUMBER PAGES : 3	N BAKHAZI, RANWA 41 LAUREL RD BLUEMONT, VA. 20135 PAGE: 130 MAP: 17A1415	N 349,900.00 PIN: 21000	DBS	100%
09/10/21	212732	LLOYD, JAMES RECORDED TIME: 15:27 DESCRIPTION 1: LOT 5 CHAPEL DISTRICT DATE OF DEED : 08/23/21 BOOK: 688 NUMBER PAGES : 3	N LILLY, DAVID 72 LIME MARL LANE BERRYVILLE, VA. 22611 PAGE: 170 MAP: 22D15	N 183,900.00 PIN: 183900 w/imp.	DBS	100%
09/13/21	212739	PORTNER-DAY, CINDY JILL RECORDED TIME: 13:09 DESCRIPTION 1: BATTLETOWN DISTRICT DATE OF DEED : 00/00/00 BOOK: 688 NUMBER PAGES : 3	N PORTNER-DAY, CINOY JILL 3143 CASTLEMAN RD BERRYVILLE, VA. 22611 PAGE: 221 MAP: 1616	N .00 PIN: 482,800 w/imp.	DC	100%
09/15/21	212758	PORTNER, CINDY RECORDED TIME: 15:50 DESCRIPTION 1: DATE OF DEED : 00/00/00 BOOK: 688 NUMBER PAGES : 3	N SAME N/A N/A, XX. 00000 0000 PAGE: 373 MAP:	N .00 PIN:	PM	100%
09/15/21	212759	MARCHISANO, MARK D RECORDED TIME: 16:19 DESCRIPTION 1: TOWN OF BERRYVILLE DATE OF DEED : 00/00/00 BOOK: 688 NUMBER PAGES : 2	N EATON, SARAH 308 E MAIN ST BERRYVILLE, VA. 22611 PAGE: 376 MAP: 14A2A147	N 300,000.00 PIN: 243800 w/imp.	DBS	100%
09/16/21	212764	JURNEY, CYNTHIA P RECORDED TIME: 11:28 DESCRIPTION 1: GREENWAY DISTRICT DATE OF DEED : 00/00/00 BOOK: 688 NUMBER PAGES : 3	N HOULIHAN, PATRICIA 1742 OLD OAK LANE FRONT ROYAL, VA. 22630 PAGE: 443 MAP: 37A3AA	N 402,000.00 PIN: 276,000 w/imp.	DBS	100%
09/16/21	212766	D.R. HORTON RECORDED TIME: 12:26 DESCRIPTION 1: SHEN CROSSING LOT 61 DATE OF DEED : 00/00/00 BOOK: 688 NUMBER PAGES : 3	N TAYLOR, KRISTIE MICHELLE 64 WILSON DR BERRYVILLE, VA. 22611 PAGE: 463 MAP: 14G161	N 476,990.00 PIN: 387,200 w/imp.	DBS	100%
09/16/21	212771	STAMPER, NORA RECORDED TIME: 14:20 DESCRIPTION 1: BATTLETOWN DISTRICT DATE OF DEED : 00/00/00 BOOK: 688 NUMBER PAGES : 4	N FURLONG, MAREIKE 820 PIONEER LN BOYCE, VA. 22620 PAGE: 489 MAP: 2527	N 200,000.00 PIN: 330,000 w/imp.	DBS	100%

CLARKE COUNTY CIRCUIT COURT
 MONTH END DEEDS OF PARTITION AND CONVEYANCE
 LOCAL TAXATION DEPARTMENT
 COUNTY
 FOR SEPTEMBER, 2021

RECORDED	INSTRUMENT	GRANTOR	(X) GRANTEE/ADDRESS	(X) CONSIDERATION	TYPE	PERCENT
09/17/21	212774	STEVAERT, PETER A; ETUX RECORDED TIME: 09:00 DESCRIPTION 1: TOWN OF BERRYVILLE, HERMITAGE, LOT 194 DATE OF DEED : 09/15/21 BOOK: 688 NUMBER PAGES : 2	N MONEY, MICHAEL AVERY; ETAL 408 MADDEN STREET BERRYVILLE, VA. 22611 PAGE: 516 MAP: 14A8-4-194	N 560,000.00	OBS	100%
						488,200 w/imp.
09/20/21	212786	JACKMAN, JENNIFER KAY RECORDED TIME: 10:21 DESCRIPTION 1: 25.4382 ACRES DATE OF DEED : 00/00/00 BOOK: 688 NUMBER PAGES : 3	N SALIMI, BEHZAD 20631 BLUE RIDGE MTN RD PARIS, VA. 20130 PAGE: 594 MAP: 40B14	N 695,900.00	DBS	100%
						771,900 w/imp
09/20/21	212788	O'BRIEN, JOHN M RECORDED TIME: 11:23 DESCRIPTION 1: BATTLETOWN DISTRICT DATE OF DEED : 00/00/00 BOOK: 688 NUMBER PAGES : 2	N BOWEN, THOMAS C N/A N/A, XX. 00000 0000 PAGE: 612 MAP: 26A107B	N 167,000.00	DBS	100%
						120,000 w/imp.
09/20/21	212796	COMPHER, JAMES C; JR RECORDED TIME: 11:55 DESCRIPTION 1: BATTLEFIELD ESTATES LOT 22 DATE OF DEED : 00/00/00 BOOK: 688 NUMBER PAGES : 4	N COMPHER, JAMES C; JR N/A N/A, XX. 00000 0000 PAGE: 627 MAP: 14A7722	N .00	DG	100%
09/20/21	212797	QUARFORTH, JAMES S RECORDED TIME: 12:01 DESCRIPTION 1: DATE OF DEED : 00/00/00 BOOK: 688 NUMBER PAGES : 5	N LAAVEG, PAUL N/A N/A, XX. 00000 0000 PAGE: 631 MAP: 17A210110	N .00	DG	100%
09/20/21	212799	SEYMOUR, BRYANT RECORDED TIME: 13:25 DESCRIPTION 1: DATE OF DEED : 00/00/00 BOOK: 688 NUMBER PAGES : 2	N SAME N/A N/A, XX. 00000 0D00 PAGE: 657 MAP:	N .00	PM	100%
09/20/21	212808	RUSSELL, DENISE RECORDED TIME: 14:45 DESCRIPTION 1: CHAPEL DISTRICT DATE OF DEED : 09/16/92 BOOK: 688 NUMBER PAGES : 2	N RUSSELL, JEROME LANTZ 195 GINNS RD BOYCE, VA. 22620 PAGE: 747 MAP: 20A21D	N 17,500.00	DBS	100%
						933,200 w/imp.
09/21/21	212810	MANSFIELD DUNLAP LLC RECORDED TIME: 11:38 DESCRIPTION 1: VILLAGE OF MILLWOOD DATE OF DEED : 00/00/00 BOOK: 688 NUMBER PAGES : 3	N DALE, CARTER PHELPS 1974 MILLWOOD ROAD BOYCE, VA. 22620 PAGE: 750 MAP: 30AA25	N 279,000.00	DBS	100%
						162,000 w/imp.

CLARKE COUNTY CIRCUIT COURT
MONTH END DEEDS OF PARTITION AND CONVEYANCE
LOCAL TAXATION DEPARTMENT
COUNTY
FOR SEPTEMBER, 2021

RECORDED	INSTRUMENT	GRANTOR	(X) GRANTEE/ADDRESS	(X) CONSIDERATION	TYPE	PERCENT
09/21/21	212816	SMITH, B SCOTT; ETUX RECORDED TIME: 12:55 DESCRIPTION 1: LONGMARSH DISTRICT, LOT 7, 44.4445 ACRES DATE OF DEED : 09/17/21 BOOK: 688 NUMBER PAGES : 3	N SHRIVER, JUSTIN G; ETUX 507 QUEENSHIP LANE BERRYVILLE, VA. 22611 PAGE: 783 MAP: 1-A-4	N 313,100.00 565,000	DBS	100% 313,100
4 (5)						
09/21/21	212823	ARTHUR, SEAN RECORDED TIME: 13:54 DESCRIPTION 1: GREENWAY DISTRICT DATE OF DEED : 00/00/00 BOOK: 688 NUMBER PAGES : 3	N SAKE, ISIS N/A N/A, XX. 00000 0000 PAGE: 825 MAP: 30A22D	N 1,350,000.00	DBS	100% 661,700 w/ imp.
8756 (2)						
09/22/21	212826	PORTER, SANDON RECORDED TIME: 09:22 DESCRIPTION 1: DATE OF DEED : 09/22/21 BOOK: 688 NUMBER PAGES : 2	N PORTER, KATIE 2042 HARRY BYRD HWY BLUEMONT, VA. 20135 PAGE: 848 MAP:	N .00	DQC	100%
09/22/21	212830	MJONES, GLORENE D RECORDED TIME: 12:23 DESCRIPTION 1: BATTLETOWN DISTRICT DATE OF DEED : 00/00/00 BOOK: 688 NUMBER PAGES : 1	N MJONES, MATTHEW M N/A N/A, XX. 00000 0000 PAGE: 872 MAP: 17A4292L39	N .00	DG	100%
09/22/21	212835	DEAL, JANET LO RECORDED TIME: 14:10 DESCRIPTION 1: TOWN OF BOYCE DATE OF DEED : 00/00/00 BOOK: 688 NUMBER PAGES : 3	N DEAL, CHARLOTTE V N/A N/A, XX. 00000 0000 PAGE: 877 MAP: 21A2A7	N .00	D00S	100%
09/22/21	212836	JONES, MATTHEW PAGE RECORDED TIME: 15:28 DESCRIPTION 1: DATE OF DEED : 00/00/00 BOOK: 688 NUMBER PAGES : 30	N COUNTY OF CLARKE N/A N/A, XX. 00000 0000 PAGE: 880 MAP: 29A35A	N .00	DE	100%
09/23/21	212845	CURRAN, CHRISTOPHER M RECORDED TIME: 14:35 DESCRIPTION 1: DATE OF DEED : 00/00/00 BOOK: 14 NUMBER PAGES : 1	N LEE, JACQUELINE P N/A N/A, XX. 00000 0000 PAGE: 64 MAP: 24A25E	N .00	OPM	100%
09/23/21	21286	TAPSCOTT, KATELYN RECORDED TIME: 15:23 DESCRIPTION 1: CHAPEL ARTHUR SHANE SUBDV. DATE OF DEED : 09/22/21 BOOK: 688 NUMBER PAGES : 2	N VOROUS, JEREMY 204 OLD CHAPEL AVE BOYCE, VA. 22620 PAGE: 974 MAP: 21A231	N 259,900.00	DBS	100% 187,000 w/ imp.
4964 (1)						

CLARKE COUNTY CIRCUIT COURT
MONTH END DEEDS OF PARTITION AND CONVEYANCE
LOCAL TAXATION DEPARTMENT
COUNTY
FOR SEPTEMBER, 2021

RECORDED	INSTRUMENT	GRANTOR	(X) GRANTEE/ADDRESS	(X) CONSIDERATION	TYPE	PERCENT
09/23/21	212848	MCDONALD, MALCOLM	N JETT, AMANDA N/A N/A, XX. 00000 0000	N 260,000.00	DBS	100%
		RECORDED TIME: 16:15 DESCRIPTION 1: TOWN OF BERRYVILLE DATE OF DEED : 00/00/00 BOOK: 688 NUMBER PAGES : 2	PAGE: 990 MAP: 14A1615	PIN:		161,700 w/imp.
09/24/21	212852	RIDGEWAY, JOAN C	N SAME N/A N/A, XX. 00000 0000	N .00	PM	100%
		RECORDED TIME: 11:28 DESCRIPTION 1: LONGMARSH DISTRICT DATE OF DEED : 00/00/00 BOOK: 689 NUMBER PAGES : 2	PAGE: 14 MAP: 3A13	PIN:		
09/27/21	212878	BOYERS, RUSSELL A	N BOYERS, RUSSELL N/A N/A, XX. 00000 0000	N .00	DG	100%
		RECORDED TIME: 12:09 DESCRIPTION 1: CAREFREE ACRES LOT 1005 DATE OF DEED : 00/00/00 BOOK: 689 NUMBER PAGES : 4	PAGE: 140 MAP: 39111005	PIN:		
09/27/21	212881	O.R. HORTON	N MILES, TERRI ANN TOLITHA N/A N/A, XX. 00000 0000	N 399,990.00	DBS	100%
		RECORDED TIME: 15:42 DESCRIPTION 1: FELLOWSHIP SQUARE LOT 21 DATE OF DEED : 00/00/00 BOOK: 689 NUMBER PAGES : 2	PAGE: 168 MAP: 14G221	PIN:		325,700 w/imp.
09/28/21	212899	RUOS, MARY C	N BROWN, KELSEY 140 PARIS HEIGHTS LANE PARIS, VA. 20130	N 575,000.00	DBS	100%
		RECORDED TIME: 13:28 DESCRIPTION 1: GREENWAY DISTRICT, LOT 12, 5.217 ACRES DATE OF DEED : 09/27/21 BOOK: 689 NUMBER PAGES : 2	PAGE: 291 MAP: 40A-3-12	PIN:		473,500 w/imp.
09/28/21	212888	ARGHYRIS, GARY ROGERS	N GILLIS, MARYJEAN N/A N/A, XX. 00000 0000	N 260,000.00	DBS	100%
		RECORDED TIME: 13:40 DESCRIPTION 1: TOWN OF BERRYVILLE DATE OF DEED : 00/00/00 BOOK: 689 NUMBER PAGES : 1	PAGE: 209 MAP: 14A215D12	PIN:		127,300
09/28/21	212894	DR HORTON	N BIBB, RICHARD JORDAN N/A N/A, XX. 00000 0000	N 495,990.00	DBS	100%
		RECORDED TIME: 14:36 DESCRIPTION 1: SHEN CROSSING LOT 60 DATE OF DEED : 00/00/00 BOOK: 689 NUMBER PAGES : 2	PAGE: 228 MAP: 14G160	PIN:		30,000
09/29/21	212903	HAGGERTY, EDWARD D	N KOSIOREK, SHANA N/A N/A, XX. 00000 0000	N .00	DG	100%
		RECORDED TIME: 10:34 DESCRIPTION 1: CHAPEL DISTRICT DATE OF DEED : 00/00/00 BOOK: 689 NUMBER PAGES : 2	PAGE: 307 MAP: 6A59	PIN:		

CLARKE COUNTY CIRCUIT COURT
 MONTH END DEEDS OF PARTITION AND CONVEYANCE
 LOCAL TAXATION DEPARTMENT
 COUNTY
 FOR SEPTEMBER, 2021

RECORDED	INSTRUMENT	GRANTOR	(X) GRANTEE/ADDRESS	(X) CONSIDERATION	TYPE	PERCENT
09/29/21	212913	D.R HORTON INC RECORDED TIME: 13:14 DESCRIPTION 1: LOT 3 SHENANDOAH CROSSING DATE OF DEED : 09/28/21 BOOK: 689 NUMBER PAGES : 2	N HERNANDEZ, BLANCA ESTELA 65 WILSON ORIVE BERRYVILLE, VA. 22611 PAGE: 367 MAP: 14G13	N 408,990.00	OBS	100% 80,000
09/29/21	212916	PISAREV, KLIMENTY O RECORDED TIME: 14:25 DESCRIPTION 1: BATTLETOWN OISTRRICT DATE OF DEED : 00/00/00 BOOK: 689 NUMBER PAGES : 3	N MILLER, BENJAMIN L 421 HAWTHORNE LN BERRYVILLE, VA. 22611 PAGE: 104 MAP: 15122	N 598,900.00	OBS	100% 515,000 w/imp
09/29/21	212920	DILLOW, JERYL E RECORDED TIME: 14:57 DESCRIPTION 1: LONGMARSH DISTRICT DATE OF DEED : 00/00/00 BOOK: 689 NUMBER PAGES : 2	N ROBERTS, GEORGE R; III N/A N/A, XX. 00000 0000 PAGE: 440 MAP: 741	N 150,000.00	OBS	100% 114,500
09/29/21	210004851	HARDESTY, CHARLES T; III RECORDED TIME: 15:27 DESCRIPTION 1: DATE OF DEED : 09/29/21 BOOK: 107 NUMBER PAGES : 4	N/A N/A PAGE: 592 MAP:	.00	QUAL	00%
09/30/21	212922	WALTERS, MARY ANN MARGUERIE RECORDED TIME: 10:11 DESCRIPTION 1: DATE OF DEED : 00/00/00 BOOK: 689 NUMBER PAGES : 2	N WALTERS, SUMNER FRANCIS DUDLEY N/A N/A, XX. 00000 0000 PAGE: 449 MAP:	N .00	OISC	100%
09/30/21	212923	IVE, LEANNA KAY RECORDED TIME: 10:12 DESCRIPTION 1: DATE OF DEED : 00/00/00 BOOK: 689 NUMBER PAGES : 2	N WALTERS, SUMNER FRANCIS DUDLEY N/A N/A, XX. 00000 0000 PAGE: 451 MAP:	N .00	DISC	100%
09/30/21	212924	IVE, CHARLES ANTHONY RECORDED TIME: 10:13 DESCRIPTION 1: DATE OF DEED : 00/00/00 BOOK: 689 NUMBER PAGES : 2	N WALTERS, SUMNER FRANCIS DUDLEY N/A N/A, XX. 00000 0000 PAGE: 453 MAP:	N .00	DISC	100%
09/30/21	212935	CURRAN, CHRISTOPHER RECORDED TIME: 13:25 DESCRIPTION 1: BATTLETOWN DIST 3.22 ACRES DATE OF DEED : 09/24/21 BOOK: 689 NUMBER PAGES : 3	N POWERS, CIERRA 487 BELL LANE BERRYVILLE, VA. 22611 PAGE: 492 MAP: 24A25E	N 387,990.00	OBS	100% 270,900 w/imp

CLARKE COUNTY CIRCUIT COURT
MONTH END DEEDS OF PARTITION AND CONVEYANCE
LOCAL TAXATION DEPARTMENT
COUNTY
FOR SEPTEMBER, 2021

RECORDED	INSTRUMENT	GRANTOR	(X) GRANTEE/ADDRESS	(X) CONSIDERATION	TYPE	PERCENT
09/30/21	210004852	BURTON, JACQUELYN BRIDGES	N/A	.00	QUAL	00%
		RECORDED TIME: 15:54	N/A			
		DESCRIPTION 1: GREENWAY DISTRICT, LOT 1004 CAREFREE ACRES				
		DATE OF DEED : 09/30/21 BOOK: 107 PAGE: 600 MAP:			PIN:	
		NUMBER PAGES : 0				
09/30/21	210004853	BURTON, HARRY HARDING	N/A	.00	PROBATE	00%
		RECORDED TIME: 15:55	N/A			
		DESCRIPTION 1: GREENWAY DISTRICT, LOT 1004, CAREFREE ACRES	RECD COPY OF WILL			
		DATE OF DEED : 09/30/21 BOOK: 107 PAGE: 602 MAP:			PIN:	
		NUMBER PAGES : 3				

CLARKE COUNTY CIRCUIT COURT
MONTH END DEEDS OF PARTITION AND CONVEYANCE
LOCAL TAXATION DEPARTMENT
COUNTY
FOR SEPTEMBER, 2021

RECORDED INSTRUMENT GRANTOR (X) GRANTEE/ADDRESS (X) CONSIDERATION TYPE PERCENT

***** DEEDS TRANSFER UPON DEATH *****

09/07/21 212693 MILLER, THOMAS O N THOMAS AND CYNTHIA MILLER TRUS N .00 DTD 100%
RECORDED TIME: 13:42 N/A N/A, XX. 00000 0000
DESCRIPTION 1: CHAPEL DISTRICT
DATE OF DEED : 00/00/00 BOOK: 687 PAGE: 822 MAP: 12A33E PIN:
NUMBER PAGES : 3

**Clarke County Fire-Rescue
FY 21-22 Closing Balance Summary**

Description	Jul-21	Aug-21	Sep-21	Oct-21	Nov-21	YTD Totals
Billable Calls						
Enders (Co 1)	75	102	87			264
Boyce (Co 4)	16	16	15			47
Blue Ridge (Co 8)	3	0	9			12
Total # of Billable Calls	94	118	111			323
ALS Trips Billed	42	61	50			153
BLS Trips Billed	49	56	57			162
TNT Trips Billed	3	1	4			8
Total	94	118	111			323
Net Mileage Reimbursement						
Enders (Co 1)	\$1,099.38	\$6,298.17	\$6,483.44			\$13,880.99
Boyce (Co 4)	\$90.86	\$1,086.71	\$995.74			\$2,173.31
Blue Ridge (Co 8)	\$24.96	\$0.00	\$349.04			\$374.00
Total	\$1,215.20	\$7,384.88	\$7,828.22			\$16,428.30
Calls Dispatched						
Co 1 Career	83	87	89			259
Co 1 Volunteer	5	6	4			15
Co 1 Split	16	38	28			82
Co 4 Career	4	3	2			9
Co 4 Volunteer	11	14	13			38
Co 4 Split	14	14	10			38
Co 8 Career	3	0	6			9
Co 8 Volunteer	4	3	4			11
Co 8 Split	0	0	3			3
Unknown	27	19	33			79
Total # of Calls Dispatched	167	184	192			543
Patient Payments	\$3,408.75	\$4,325.69	\$4,203.07			\$11,937.51
TNT Payments	\$50.00	\$300.00	\$300.00			\$650.00
Total Payments	\$40,485.35	\$43,814.95	\$35,609.65			\$119,909.95

Clarke County Demand Response Metrics

Month	Service Days	Service Hours	Passengers	Miles Traveled
Jan-21	20	80	116	625
Feb-21	16	64	84	942
Mar-21	23	92	122	1,298
Apr-21	22	88	177	1,145
May-21	21	84	169	1,256
Jun-21	22	88	177	1,362
Jul-21	21	84	200	1,310
Aug-21	22	88	205	1,392
Sep-21	21	84	152	1,390
Oct-21				
Nov-21				
Dec-21				

HISTORIC BERRYVILLE, VIRGINIA



BARNs OF ROSE HILL

ENRICHING LIVES THROUGH THE ARTS, EDUCATION, AND COMMUNITY

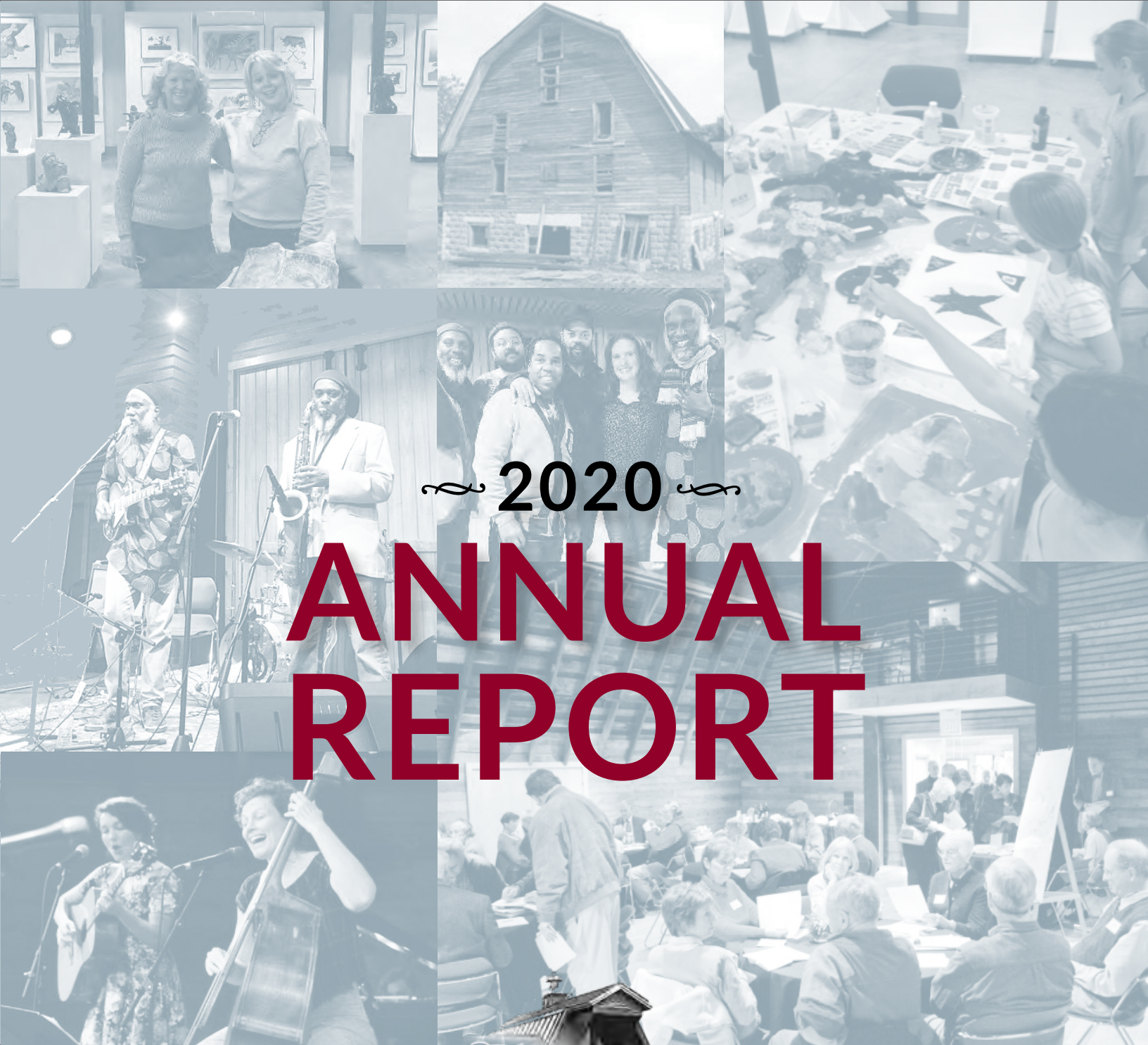

2020

ANNUAL REPORT



Dear Friends,



We are pleased to bring you the 2020 Barns of Rose Hill Annual Report. As we consider the past year and the many challenges faced by our community, we are grateful for the role we were able to play in working with so many artists, musicians, volunteers, and partners to continue offering and expanding our programming in order to serve and celebrate the arts and human spirit.



As we began planning for our 10th Anniversary Celebration, we were confronted with an extraordinary shift in the approach required to connect our community with itself and the arts. Thankfully, with your help and support, we have been able to adapt and grow, transitioning to expanded social platforms enabling us to expand our reach to an even larger community.

With your generous help, we will continue to create opportunities for artists and art lovers throughout the area. **Thank you for the positive impact you have made for so many and for sustaining us as patrons and donors. We look forward to seeing you soon!**

Sincerely,

Michael Hobert, Chair

Sarah Ames, Executive Director

70+ Virtual Programs
and Livestreams

30+
In-Person
Events

2,150
Visitors

23,000+
Online Audience Members

Over **200** Artists Supported



Financial Summary

INCOME

Contributions	374,541.00
Membership	12,488.00
Fundraising Events	44,529.00
Rentals	4,683.00
Programming	75,775.00
Investments	13,938.00
Other	4,433.00
Total Income	530,387.00

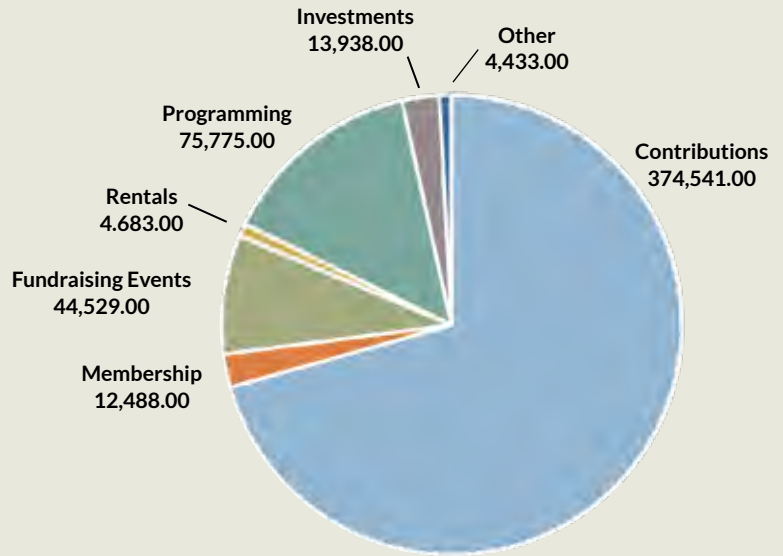

EXPENSES

Administrative	89,467.00
Development	41,602.00
Programming	152,775.00
Total Expenses	283,844.00

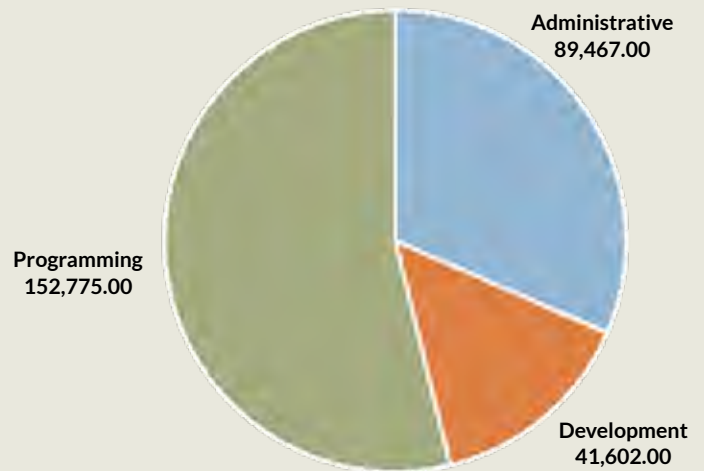

NET ASSETS

Unrestricted	89,569.00
Temporarily Restricted	38,748.00
Permanently Restricted	843,676.00
Total Net Assets	971,993.00

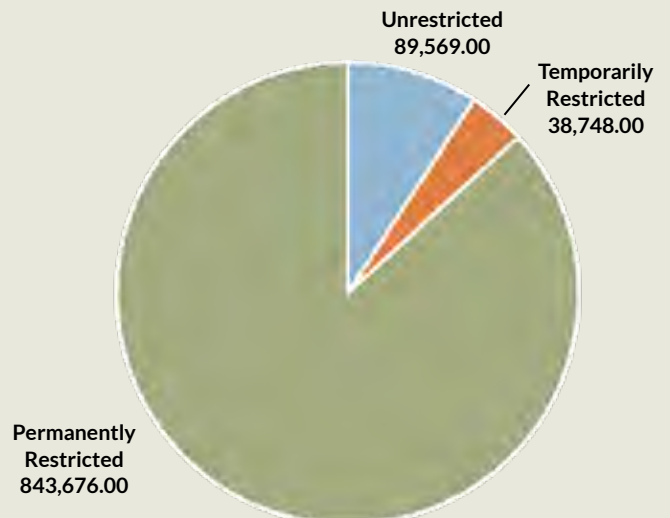

Resiliency as we face COVID

In June of 2020, Barns of Rose Hill took delivery of a beautiful double-manual harpsichord. Mr. Bruce Reynolds, a retired attorney and amateur musician from McLean, VA, gifted the harpsichord to the Barns. In November, 30 lucky attendees were on-hand for the instrument's debut, with a concert by **Patrick Merrill and Grace Srinivasan**.



Patrick Merrill and Grace Srinivasan during their November 2020 performance at the Barns

We are eager to continue our classical music programming into 2021.

THURSDAY, AUG. 18 Barns of Rose Hill kicks off the **Appalachian Chamber Music Festival's** inaugural season. The festival celebrates the rich history, nature, and culture of the area through poignant and powerful chamber music experiences that are both meaningful and relevant to our times.

SATURDAY, NOV. 13 the Barns will present **Peter and the Wolf, An Interactive Experience**. This family-friendly performance of Sergei Prokofiev's classic "Peter and the Wolf" will feature the **Rose Hill Chamber Orchestra**. Let the orchestra weave the musical story of young Peter and friends as they boldly battle the fierce wolf. Families are invited to join us before the show to make puppets of the characters. Children will learn about orchestra instruments and how they represent each character in this symphonic fairytale. Barns of Rose Hill welcomes conductor **Garrick Zoeter** to the podium for this exciting evening. Mr. Zoeter holds degrees from The Juilliard School and Yale University and serves as professor of clarinet at Shenandoah University. This event is offered to our community free of charge thanks in part to a grant from the **Marion Park Lewis Foundation**.

“Inspired by” Quilt Exhibit

Barns of Rose Hill presented the **Inspired by Endangered Species** exhibit in August and September of 2020. This exhibit was the fourth “Inspired by” quilt show hosted by the Barns. Once again, it was very well received by our visitors.



During the initial pandemic lockdown, the Barns was closed to the public. Luckily, by summer, we were able to reopen the visitor center and our exhibits. We were thrilled to provide a safe place for people to engage, enjoy the artwork, and break up a bit of the isolation felt by so many during 2020.

Northern Virginia-based quilter **Donna DeSoto** organized the **Inspired by Endangered Species** exhibit.

Like the previous exhibits organized by Donna, she worked with her extensive network of quilters to assign each artist a different subject, in this case an animal or plant threatened by extinction. She assembled **182** separate quilts into a truly amazing exhibit. The Barns saw over 300 visitors, all masked and socially distanced, during its two-month stay.

Outdoor Live Music

An Exciting Partnership with
B-Chord Brewing Company

For five concerts throughout the summer and fall of 2020, Barns of Rose Hill partnered with **B-Chord Brewing Company** in Round Hill, VA. With this partnership, the Barns was able to present five concerts that would have otherwise been cancelled due to the pandemic. B-Chord offers ample outdoor space, and over 700 attendees were able to safely experience great music under the stars. Many thanks to Marty Dougherty and the B-Chord Brewing team!



Endowment News

Eugene B. Casey Foundation

Five-Year Endowment Fund Challenge Update

2020 saw the successful completion of year four of five of the **Eugene B. Casey Foundation** endowment challenge. The Casey Foundation has matched, dollar for dollar, \$100,000 in endowment gifts every year over the past four years. The final year of the challenge grant will end on **August 31**. This is your last opportunity to participate in the endowment challenge.

In harmony with annual memberships and donations, gifts to the endowment provide an opportunity to establish long-term financial stability for the Barns; an opportunity to have a “leg-up” as our organization moves ahead. We can’t wait to celebrate this major milestone with our endowment donors after August 31. To discuss a gift to the endowment, or for more information about the endowment, please contact Sarah Ames, sarah.ames@borh.org.

CFNSV Establishes Barns of Rose Hill Endowment Fund



The **Community Foundation of the Northern Shenandoah Valley (CFNSV)** has established a new endowment fund for the benefit of Barns of Rose Hill to be known as the “**Robert and Genevieve Boxley Barns of Rose Hill Fund for the Performing Arts**.” The fund was recently started with a \$1 million contribution from the estate of the late Dr. Robert Boxley (*shown left with wife Genevieve at the 2013 BORH Gala*). Earnings from this endowment will be used to support Barns of Rose Hill programs, performances, exhibits, and general operations.

A resident of Winchester, VA, Dr. Boxley died in 2018. He was an economist for numerous U.S. government agencies. Dr. Boxley was a member and former president of the Winchester-Frederick County Historical Society, in addition to serving on the board of the Handley Regional Library and other historical preservation organizations.

Dr. Boxley’s relationship with the Barns began shortly after its opening when his impressive collection of model boats was exhibited there. He and his wife, Genevieve, loved music and regularly attended concerts at the Barns. The Boxleys donated their piano to the organization and internationally-known concert pianists have performed on the instrument.

“The Community Foundation of the Northern Shenandoah Valley is honored to be able to bring Dr. Boxley’s wishes to reality with the establishment of this endowment fund. We know the Barns of Rose Hill and the entire Shenandoah Valley will benefit tremendously as the proceeds from Dr. Boxley’s generosity support the Barns of Rose Hill in the years to come,” commented Larry Weiss, executive director of the CFNSV.

“We’re honored by the Boxleys’ wish to support the work of the Barns through the income from this fund,” said Barns of Rose Hill executive director, Sarah Ames, “This gift comes at a particularly challenging but exciting time in the life of the Barns as we prepare to celebrate our tenth anniversary year of public service as a center for the arts, education, and community.”

Anniversary Events

Celebrating a Decade of Barns of Rose Hill



In September 2011, Barns of Rose Hill opened our doors. Now, in 2021, we celebrate ten years of enriching lives through the arts, education, and community. Join us in celebrating Barns of Rose Hill, the community we serve, and the successes of our first decade! Three signature anniversary events have been planned, and you are invited to join us.

BARNs OF ROSE HILL TEN-YEAR ANNIVERSARY OUTDOOR COMMUNITY CELEBRATION - SATURDAY, JUL. 31, 5:00-9:00 PM:

Join us for an evening of music, food, and fun for the whole family!

Our celebration will be held outdoors on the lawn between Barns of Rose Hill and the Clarke/Berryville Government Center. The event starts at 5:00 PM and is free to the public. There will be lots of kid-friendly activities, including magic, balloon animals, face painting, arts and crafts, and an instrument petting zoo. **Hog-it-Up BBQ** and **Generations Gourmet** food trucks will be on site, as well as free ice cream for all attendees, so come hungry. Grammy nominee

Cheick Hamala Diabaté and his band will take the outdoor stage at 7:00 PM.

His blend of African and Western rhythms will have the audience on its feet!



Photo courtesy of Cheick Hamala Diabaté.

HISTORY OF BARNs OF ROSE HILL EXHIBIT: Beginning in October, the Barns will host an **Interactive Exhibit** highlighting the history, experiences, and community behind the Barns of Rose Hill. Celebrate our world-class programming with highlights from the last decade. See and hear the story of the Barns.

ANNUAL GALA - SATURDAY, OCT. 16: As our signature fundraiser, the gala is always a highlight of the year and this year is no exception. This year's gala will be a special celebration in which we toast the Barns of Rose Hill, our supporters, and the future of our organization. Once again this year, the Gala will also include an online auction. Details for this event can be found by visiting our website.



PRESERVE A LEGACY: Become a permanent part of the Barns of Rose Hill with a special **Anniversary Barns Brick!** For \$250, you can have your name inscribed on a commemorative brick that will be placed in the Barns of Rose Hill front walkway.

Your continued support allows us to continue to enrich lives through the arts, education, and community and we couldn't do it without you!

Become and member, sponsor, or make a donation at barnsofrosehill.org and click on the **Support Us** tab.

Recognition of Donors

The donors listed in *italics* contributed to the Barns of Rose Hill Endowment Fund in 2020. We truly thank them for helping ensure the future of our organization!

Many thanks to our donors who contributed \$10,000 or more in 2020

County of Clarke
Diana and Kelly Kincannon
Ms. Jacqueline B. Mars
Pat Robinson
The Eugene B. Casey Foundation
The Hopewell Fund - Vanguard Charitable
The Luminescence Foundation
The Monford D. and Lucy L. Custer Foundation
Virginia Commission for the Arts

Major Donors

Mr. and Mrs. Michael Ames
The Andrew U. Ferrari Foundation
Wayne and Linda Armbrust
Audley Farm
Ms. Susan C. Bailey
Bank of Clarke County
Mr. and Mrs. H.K. Benham, III
Susan R. Bowen and Michael S. Hartley
Mr. and Mrs. Harry Byrd, III
Ms. Beverley Byrd and Mr. Keith Harrington
Mr. Tom W. Cammack
Cammack Enterprises, Inc.
Dr. and Mrs. John B. Carter
Rick and Terri T. Catlett
Robert Chamberlin
The Clara Weiss Fund
Mr. Peter Cook
Jolly DeGive
Ms. Elaine Dennison
Steve and Lucy Dorick
Mr. and Mrs. John Fisher
Mr. M. Tyson Gilpin, Jr.
Dr. and Mrs. Lucille Harris and Celie
Wendell Hawken Clatterbuck
Michael Hobert and Mary Jane Lee
John Michael Hobert
Mr. Larry Hollar
John and Kathy Hudson
James R. Wilkins Charitable Trust
The Kentland Foundation
Ms. Jean King
Marsha and Stanley Legum
Robert G. and Ann St. Clair Lesman
John and Marjorie Lewis
Loudoun Mutual Insurance Company
Doctors Laura Dabinett and Russell McKelway
Candy and Howard Means
C. Randal and Lucinda D. Mullett
Barbara Murry
Network for Good
Nulsen Family Foundation
Oak Hart Farm
Mr. and Mrs. George Ohrstrom, II
Perry Engineering
Ms. Holly Peterson
Isreal Preston
Bob and Nina Randolph
Rebecca Rice Clay and Charley Puleo
Ms. Alyce Rideout and Mr. Jim Bleakley
Tony and Karen Roper
James Rose and Susan Watkins

Mary C. Ruos
Jay and Linda Russell
Roma and John Sherman
Stephens City Chiropractic
Suzanne White McKown
Charitable Unitrust
Elsie and Mac Thompson
Town of Berryville
Mr. and Mrs. Jerry Van Voorhis
Mr. and Mrs. Adalbert Von Gontard, III
Mr. and Mrs. David Weiss
H.M. Baker, Jr. and Jean Wilson

Donors

Anne Brady Adams
Nancy Aker
Mr. and Mrs. Ronnie Allanson
Ms. Loretta M. Allison
American Legion Lloyd Williams Post 41
Barbara Armstrong
Mr. Harry L. "Jay" Arnold, Jr.
Mr. and Mrs. Scott Arthur
Ms. Anita Baarns
Mr. and Mrs. Matthew Baker
Caroline Barb
Marjorie Barber
Gale Bard
Margaret H. Barthel
Dale Barton
Matt and Kelbi Bass
Barbara J. Batterton
Battletown Animal Clinic
Steve and Deb Bauserman
Mr. and Mrs. Ron Beck
Marti Belcher
Linda Benko
Ms. Laura Bernstein and Mr. Stan Ikonen
John and Brenda Berry
Berryville Auto Parts
Berryville Dental
Anna Billman
Ms. Cemile Bingol
Mr. and Mrs. Don Black
Susan Bloss
Blue Ridge Insurance and Title Agency
Mr. and Mrs. David Bodkin
Gayle Bohlman
Dave and Mary Borger
Nathan Borger
Mr. and Mrs. William Boyce
Joshua Branham
Wally Brewer
Broy and Son Pump Service
Mark and Erin Burgess
Brian Burgher and Deborah Sudduth
Alan Burke
Ned and Margaret Burks
Mr. Jeff Burrige and Mr. Donald Poppke
Sandra Burrill
Landon and Carol Butler
Bill and Robin Byrd
Theresa Call
Beth and Glenn Caluda
Camino Real

Mr. and Mrs. Larry Camper
Taylor Capshaw
Charles and Joyce Casey
Marianne Casey and Russ Wagner
Jane Caspar
John and Connie Cermak
Terry Chandler
Mr. Hack Chappel and Ms. Baiba Schletty
Wayne and Suzie Chatfield-Taylor
Mrs. Brooke Chilvers and Mr. Rudy Lubin
Richard Chipman
Lionel and Ann Chisholm
Ms. Barbara Claggett
Mr. and Mrs. Robert W. Claytor
Mr. David Condon and Mrs. Harriett Condon
Mr. and Mrs. Lewis Michael Costello
James Craig
Dr. and Mrs. Clyde and Mizue Croswell
Ms. Norine Dagliano
Ms. Deidra Dain
Dara Bailey Design
George Darnell
Ms. Laurie Dashner
Dorothy P. Davis
Bradley Davis
Michael DeRosa
Dilzer Eye Care Associates
Lisa Donnelly
Mr. and Mrs. Richard Drake
James Droegemeyer & Cinda O'Neill
Peter and Melissa Dunning
Colleen Duryea
Enders & Shirley Funeral Homes & Crematory, Inc.
Maria Esparolini
Gina Faber
Ms. Diane B. Ferrall
Ms. Ann Finch
Mr. and Mrs. Norman M. Fine
Mr. Rudolph Flores
Christy Flory-Chandonait
Brian Forehand
Carole Fortune
Mr. and Mrs. Mike Fraser
Mr. and Mrs. John Friant, Jr.
Ellen Fried
Joan Gaidos
Dr. and Mrs. Nicholas Gemma
Patty and Jaime George
Paul and Susan Geromatta
Mr. Bill Getchell
Linda and Donald Gibson
William and Georganne Giordano
Mr. Calvin Gloss & Mrs. Lisa Gloss
Bob Nunn and Susan Godfrey
Gold Land Farms, LLC
Mr. Lawrence Goldstein & Ms. Karen Schneider
Dr. and Mrs. Robert Goshen
Gerry Gray
Greenway Garden Club
Ms. Suzanne Grobbel
Paul Hammerton
Robert Hammond
Ms. Yvonne Hansen
Ms. Rebecca L. Harriett

Ms. Helene Hatcher
Maureen Hearn
Ms. Frances Hernandez
Ray Hicks
Mr. John Hill
Ann and Rodney Hirschy
Patrick Holden
Lindsay Grant Hope
Bruce and Genie Hopkins
John Howard
Mrs. Audrey Hudson
Ingredients to Success
Alice Irvan and Bruce Shull
Joyce and David Jackson
Geneva Jackson
Mathew and Krystal James
Jim Barb Realty
Megan Jonkers
Mildred B. Keating
George and Mary Ann Kirkpatrick
Matthew and Pamela Klein
Mr. James Klenkar and Dr. Belinda Burwell
Eleanore Kobetz
Nancy Kruger
Sheila Kryston
Stuart Kurlander and David Martin
James and Suchada Langley
L'Auberge Provencale
Lil Ledford & Howard Morrison
Ms. Jennifer Lee
Bob Lee and Sue Kellon
Alex Lee and Monica Villegas-Lee
Mr. Frank Lee
Ms. Nancy Lehew-Krogusund
Mr. and Mrs. Tim Lettie
Sam and Joanna Dingus Levi
Alicia Cahalane Lewis
Dr. Joy Lewis and Mr. Richard Lewis
Mr. and Mrs. Bill Liggett
Mr. and Mrs. John Lincoln
Mr. and Mrs. Ken Livingston
Dave and Becky Lloyd
Local Wood
Mr. and Mrs. Carey Lokey
Mark and Sandy Lore
Janet Mabbitt
Barbara MacEachin
Dr. and Mrs. Matthew Mackay-Smith
Ms. Juliet H. Mackay-Smith and Mr. Charles Gobin
Mr. and Mrs. A. Mackay-Smith, Jr.
Mr. and Mrs. Justin Mackay-Smith
Mrs. Maisie Maguire
Ms. Gwen Malone
Jane Mandelbaum
Mark Burgess CPA
Ms. Mary Marks
John Martin
Mr. and Mrs. Will Martindale
Martin's Foods
Mr. Brian Mathews
Mr. and Mrs. John Matticks
Mr. & Mrs. George Maxwell
Dr. and Mrs. Martin R. Mayfield
Mr. Winslow McCagg
Linda McConnell
Chip and Cathy McConville
Ms. Rebecca White McCoy
Ms. Sally Megeath
Vickie Mertz
Mike and Money Miller
Ms. Carole Miller
Johnny and Bette Milleson
Mary Ann Milosavich
Barbara J. Mitchell

Mr. and Mrs. Larry Moore and Anne Moore
Mr. and Mrs. Michael Morency
Judge and Mrs. Dev Morrison
Joshua Muss
Dr. and Mrs. Eric Myer
Mark Nagurney
Carole and Stephen Napolitano
Mick and Joan Newman
Tony Noerpel
Bernard Nolan
Thomas Norris
Ed and Beth Novak
Stew and Fran Nystrom
Mrs. Suzanne Odiorne
Mr. Ralph Palmer
Pertti Palo
Randolph Parks
Dana Pedersen
Jeannie Perin
Ms. Kate Petranec
Larry and Connie Pettinger
Iona Pillion
Ms. Donna Polk
Ms. Linda Porter
Paula Rabkin
Julie and Bob Read
John Reddick III
Mr. and Mrs. Terry Reid
Stacey Remick-Simkins
Hank Reuling and Tressa Borland
Mr. Tony Reynolds
Mr. Robert Richard
Mr. and Mrs. John Richardson
George Riley and Roberta Taylor
Ann and Thomas Robb
Ms. Leah Robinson and Mr. Bill McShea
Mr. William Robinson
Ms. Sue Ross
Robert and Susan Ross
Mr. and Mrs. Ryan Royston
Ralf and Phyllis Reudinger
Paul Rusinko
Jesse Russell and Laurine Kennedy
Ms. Gillian Russell
Terry Schafer
Nancy Schaffer
Ms. Beverly Scheuring
Mr. Jack Schutte and Ms. Terri Morgoglione
Lee and Terrie Sheaffer
Dennis and Carol Sherman
Berk and Cheri Shervin
Chris and Diane Shipe
Dean and Janet Simons
Laura Sirgany
Tracy and William Smith
Dr. Nick Snow and Dr. Cathleen McCoy
Mr. and Mrs. Don Specht
Mr. Rick Sponseller
Lois Spreen
Mr. John Staelin and Ms. Elizabeth Locke
Mr. and Mrs. Duke Stanton
Mr. Andrew Stifler and Ms. Nicole Perry
Ms. Doris Stimpson
Francis Stockwell
Mr. and Mrs. Jack Strimple
Gail Swift
Dennis Taylor and Amanda Wilcoxon
Mr. and Mrs. William Thomas
Thomas and Talbot Real Estate
George and Nancy Thompson

Georgiann Toole
John Unger
S.E. Van Valzah
Mr. E. Hawley Van Wyck, III
Gary and Laura Van Meter
Ms. Laurie Volk
Tim and Rita Walston
Warfield Homes
Waterloo Electric
Dr. and Mrs. Raleigh Watson
Ms. Michele A. Way
Blayne Weaver
Jane Weir
Marilyn Werback
Dietrich and Helga Westphal
Mr. Michael Williams and Ms. Susan Gallagher
Debora Williams
Janet Williams
Tim and Paige Williamson
Jim and Tracee Wink
Stacey Winn
Tom and Barbara Wolf
Ms. Michele Worthing
Mrs. Alice "Cummie" York
Mr. and Mrs. Robin York
Robert Young
Ms. Marjorie Youngs
Scott and Kathleen Ziegler

In-Kind Donors

Audley Farm
Bank of Clarke County
Lisa Bell
Blue Ridge Hunt
Bonnie Blue Southern Market
The Canal House
Peter Cook
Steve and Lucy Dorick
Bruce and Donna Downing
Earthworks
Kellie Ferguson
Mike Fraser
Goodstone Inn
Jeff Harris
John Hill
Michael Hobert and Mary Jane Lee
Kathy Hudson
Geneva Jackson
Kelly and Diana Kincannon
L'Auberge Provencale
Lavender Green Floral Design
John Lewis
The Light Horse Inn
Limestone Ridge Farm
LK Wine Tours & Sales
Mackintosh Fruit Farm
Anne McIntosh
Moore & Dorsey Trees
Barb Murry
Oak Spring Garden Foundation
P.H. Miller Studio
Nancy Polo
Peggy and John Richardson
Janet M. Rider
Pat Robinson
Alan Rubin
Alexandra Sherman
Roma Sherman
Tamson Stone-Conrad
Jordan Xu

Thank you for your generous support!



Barns of Rose Hill
P.O. Box 738 | Berryville, VA 22611

Enriching lives through the arts, education, and community

BOARD OF DIRECTORS

- David Conrad
- Peter Cook
- Lucy Dorick, *Vice Chair*
- Diane Harrison - *Through July 2020*
- John Hill
- Michael Hobert, *Chair*
- Kathy Hudson - *Through Dec. 2020*
- Allen Kitselman
- Julie Miles
- JC Moore
- Barb Murry
- Kelli Patterson, *Treasurer*
- Isreal Preston
- Donald Rivers - *Through Dec. 2020*
- Patricia Robinson, *Secretary*
- Roma Sherman

Bios of our board and staff can be found by visiting barnsofrosehills.org/about.

TEAM

- Sarah Ames, *Executive Director*
- Nathan Borger, *Director of Operations*
- Morgan Morrison, *Program Director*
- Tiwana Brooks, *Office Manager*

Nonprofit Organization
U.S. Postage PAID
Mr. Print
Purcellville, VA 20132

Become a Member

We invite you to become a Member of the Barns. Secure some benefits and support Barns programs at the same time. Enjoy our great events and help bring exceptional musicians, artists, authors, and films to your community.

It is through your support that we are able to offer our diverse array of programs and talent. Your generous support through annual memberships helps to ensure we fulfill our mission to enrich lives through our performing, visual, and literary arts programs and to remain a strong and vibrant resource in our community.

Become a Member or make a donation at barnsofrosehills.org.

More Ways to Give

There are a number of giving opportunities to help support Barns of Rose Hill, including gifts of stock, IRA distributions, and more. When you make a gift of appreciated stock to the Barns of Rose Hill, your gains are put to good use. Your gift of stock is reinvested in your community, and it qualifies for a tax deduction based on the full market value. Also, if you are 70½ years of age or older, gifts made directly from your IRA to the Barns of Rose Hill will count towards your required minimum distribution (RMD) for the year. Because each giving situation is unique, Barns of Rose Hill always recommends you consult your tax advisor on your options for charitable giving.

Promote Your Business As a Program Sponsor

Whatever event you choose, thousands of people will see that you're supporting the arts, education, and community here where we live. We'll recognize your business in all our print and electronic promotions for several weeks. Your Business would receive extensive exposure and the thousands of people who follow the Barns and visit our website and Facebook page would see that you share our belief in the positive power of the arts, education, and community. For more info, please call 540-955-2004 or e-mail sarah.ames@borh.org.

BORH Gift Store

Show your support of the arts with BORH merchandise. Visit our gift store in our lobby or shop online at store.barnsofrosehills.org.

Upcoming Events

CONCERTS

- Saturday, Jul. 31 - 10-Year Anniversary Community Celebration
- Friday, Aug. 13 - Emi Sunshine
- Thursday, Aug. 19 - Appalachian Chamber Music Festival: New Beginnings
- Saturday, Aug. 28 - The Eric Byrd Trio Album Release
- Friday, Sept. 10 and Saturday, Sept. 11 - Patsy Cline Tribute Concert
- Saturday, Sept. 25 - Randy Thompson
- Saturday, Oct. 9 - Scott Miller
- Friday, Oct. 22 - Town Mountain
- Saturday, Nov. 6 - The Woodshedders
- Saturday, Nov. 13 - Peter and the Wolf- An Interactive Experience
- Saturday, Dec. 4 - A Charlie Brown Christmas with The Eric Byrd Trio

Visit barnsofrosehills.org for a complete calendar.

EDUCATIONAL

- Saturday, Sept. 25 - The Other Half: Providing for Clarke County's Poor

COMMUNITY

- First Tuesday of the Month - Trivia Night
- Thursday Evenings - Old Time Jam Sessions

ART EXHIBITS

- July-August - Leigh Henry
- September - Nancy Polo: What's Going on
- October-November - Ten-Year Anniversary Exhibit



FOLLOW US!

Facebook.com/BarnsofRoseHill | Twitter.com/visitBORH | Instagram.com/BarnsofRoseHill | YouTube.com/BarnsofRoseHill